

# **Bacterial Structure / Function & Bacterial Genetics**

*Prof. Hanan Habib & Dr. Abdulaziz Al-Khattaf*

College of Medicine ,Department of Pathology ,

KSU

# Objectives-Bacterial Structure & Function

- Define the cellular organization of bacteria and know the differences between Eukaryotes and Prokaryotes.
- Know major structures of bacteria and its functions.
- Know the structure of cell wall of bacteria including the differences between Gram positive and Gram negative bacteria and main functions.

# Objectives, cont.,

- Know the external structures of bacteria with and functions .
- Know the cytosol and internal structures of bacteria .
- Describe bacterial spores and its application in the practice of medicine.

# Objectives- Bacterial Genetics

- Know basic information about bacterial genetics and replication of bacteria .
- Describe plasmids ,its origin , types and its importance in clinical practice.
- Recalls genetics variations, including ; mutation and mechanisms of gene transfer and its implication on bacterial resistance to antimicrobial agents.

# Definition

**Bacteria** : Is a heterogenous group of uni-cellular organisms , about 1-8  $\mu\text{m}$  in diameter

**Bacteria is a Prokaryote** (has a primitive nucleus):

- ~ one chromosome
- ~ no nuclear membrane
- ~ no mitochondria
- ~ no sterols

**Bacteria contain Plasmids:** an extra piece of DNA.

# Shapes of Bacteria

- Spherical / Oval.....Cocci
- Rods.....Bacilli
- Very short Bacilli...Coccobacilli
- Tapered end .....Fusiform
- Club-shaped / Curved....Vibrio
- Helical / Spiral... ..Spirochaetes

# Shapes of Bacteria



Pneumococci

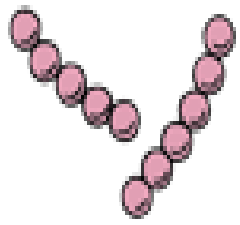

Streptococci

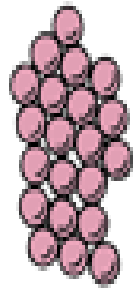

Staphylococci

**Spheres  
(Cocci)**

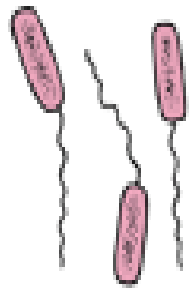

*Pseudomonas*

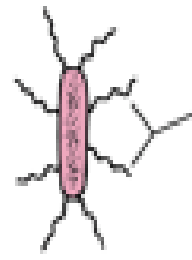

*Salmonella typhi*

Flagella

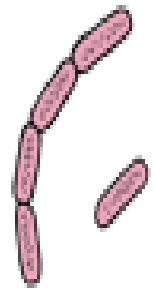

*Mycobacterium tuberculosis*

**Rods  
(Bacilli)**



*Clostridium tetani*

Spores



*Treponema*



*Leptospira*

**Spirals  
(Spirochetes)**

# Arrangements of Bacteria

## Arrangements among Cocci :

- Pairs.....Diplococci
- Chains.....Streptococci
- Clusters.....Staphylococci
- In four.....Tetrad
- Palisades.....*Corynebacterium*



# Major Structures of Bacteria

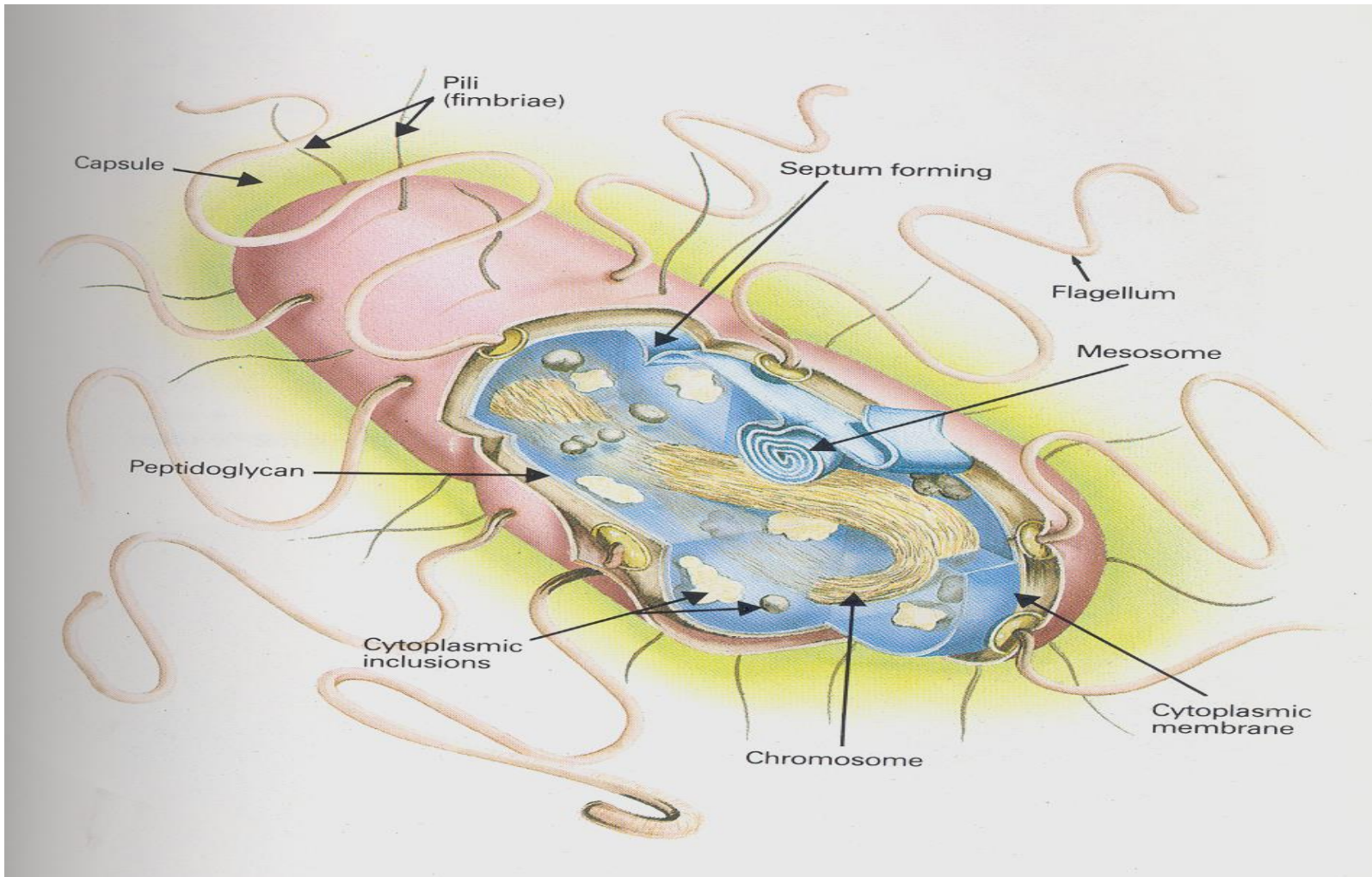

# Cell Wall of Bacteria

- Bacteria are cells with rigid cell wall surround cytoplasmic membrane and internal structures.

## Functions of cell wall:

- Rigidity
- Shapes bacteria
- Protection
- Porous / permeable to low molecular weight molecules
- Cell division
- Antigenic determinants

# Cell Wall of Bacteria

- Two groups of bacteria depending on reaction to **GRAM STAIN**:

GRAM POSITIVE BACTERIA: stain blue/purple by Gram stain

GRAM NEGATIVE BACTERIA: stain red by Gram stain

**Note : *Mycoplasma* is a bacteria that is naturally have no cell wall.**

## Chemical structure of bacterial cell wall:

- Peptidoglycan :

Rigid part , mucopeptide composed of alternating strands of *N- acetyl muramic acid* and *N- acetyl glucosamine* linked with peptide sub units.

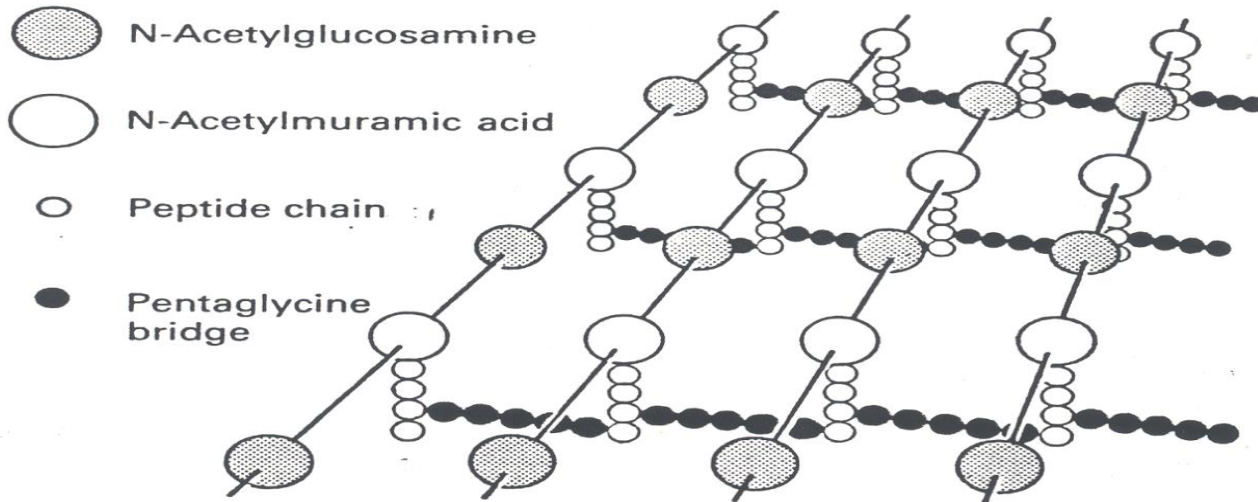
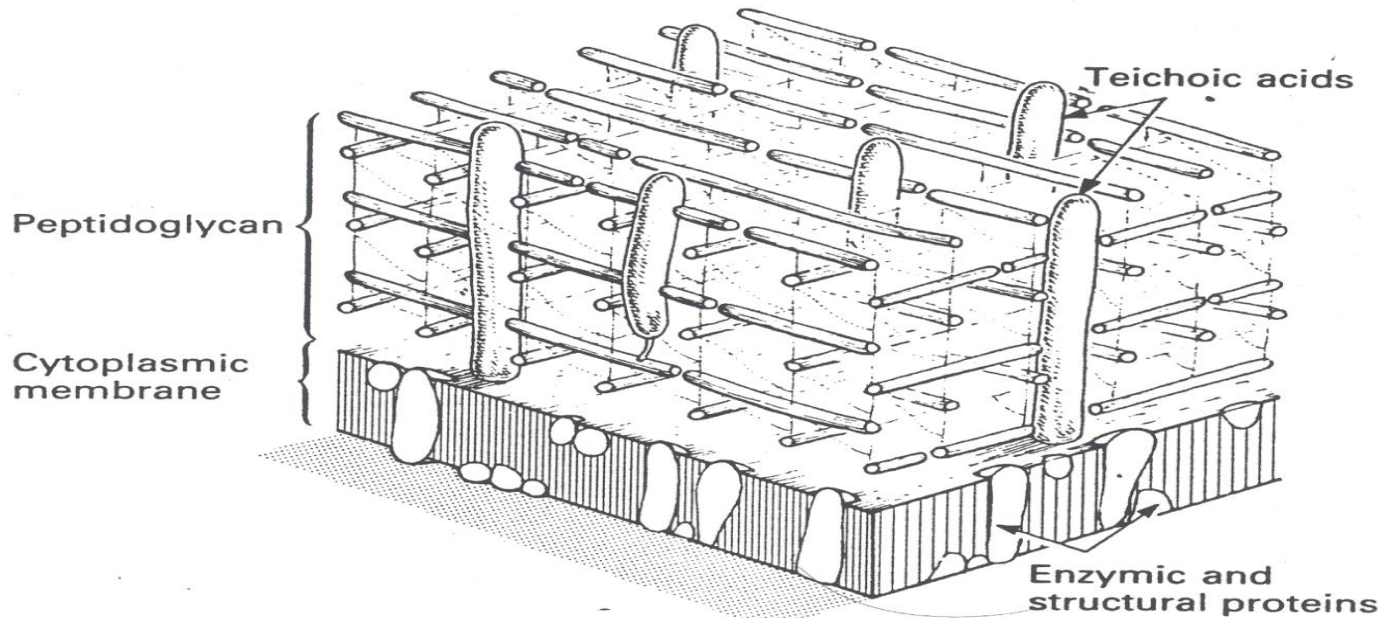

Diagram to show chemical structure of cross-linking in peptidoglycan component of cell walls. From Sharon N The Bacterial Cell Wall. Copyright (C) 1969 by Scientific American Inc. All rights reserved.



Three-dimensional representation of Gram-positive bacterial cell wall.

# GRAM STAINING

1

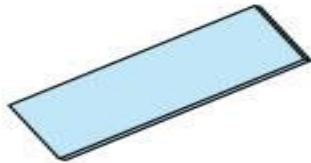

Wipe bottom of biofilm slide clean

2

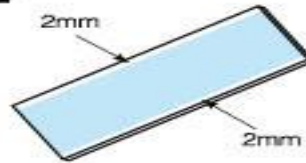

Clean top edges of slide about 2mm

3

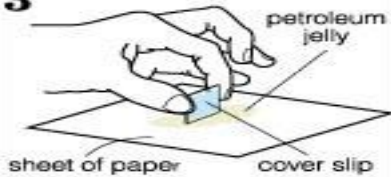

Build up a ridge of petroleum jelly on the top and bottom of a cover slip

4

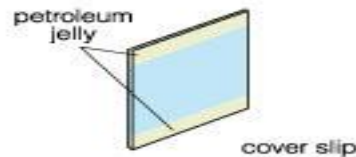

Cover slip with petroleum jelly

5

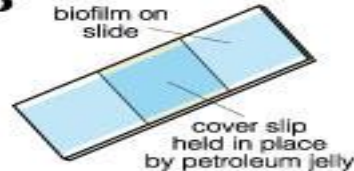

Biofilm on slide with cover slip

6

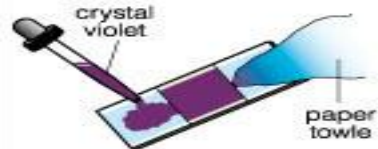

Add crystal violet - wait 30 sec.

7

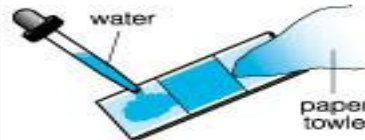

Wash with water

8

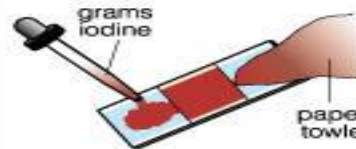

Add Grams iodine - wait 1.5 min.

9

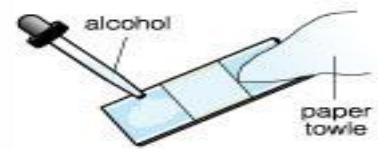

Decolorize with alcohol

10

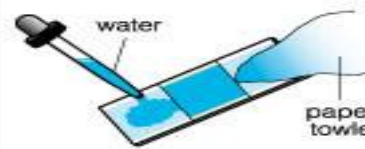

Wash with water

11



Stain with Safranin dye - wait 30 sec.

12

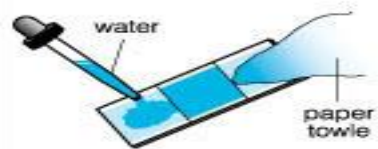

Wash with water

13

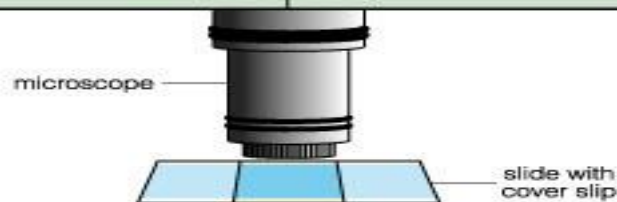

Examine under oil immersion through the cover slip

GRAM +



Fixation

GRAM -



Crystal Violet



Iodine Fixative



Decolorization



Counter stain (safranin)

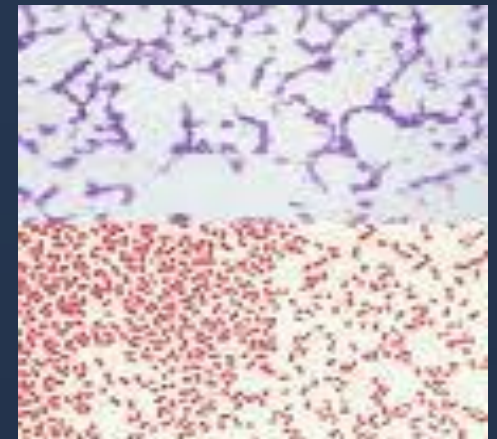

# Cell Wall of Gram Negative Bacteria

- **Thin Peptidoglycan**
- Outer membrane that contains :
  - specific proteins (porins) important in the transport of hydrophilic molecules
  - lipopolysaccharide & lipid **(ENDOTOXIN)**

# Cell Wall of Gram Positive Bacteria

- Peptidoglycan **thicker** than Gram negative bacteria.
- Closely associated with cytoplasmic membrane.
- **Teichoic acid** : anchors cell wall to cell membrane , epithelial cell adhesion.
- **Antigens** : ~ polysaccharides (Lancefield)  
~ protein (Griffith)

Outer membrane (with surface lipopolysaccharide)

Periplasmic space

Peptidoglycan

Cytoplasmic membrane

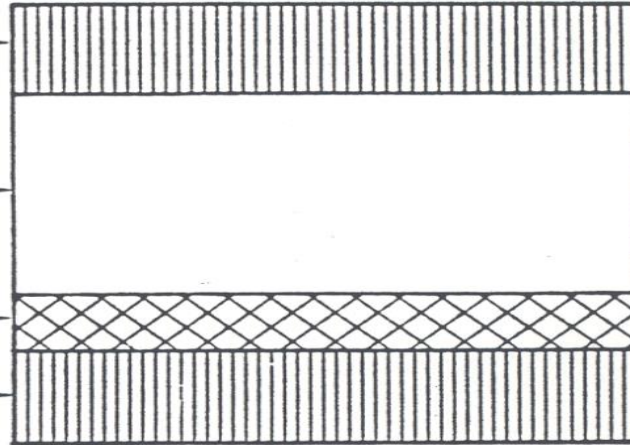

Gram-negative bacterial cell wall

Peptidoglycan (with teichoic acid)

Cytoplasmic membrane

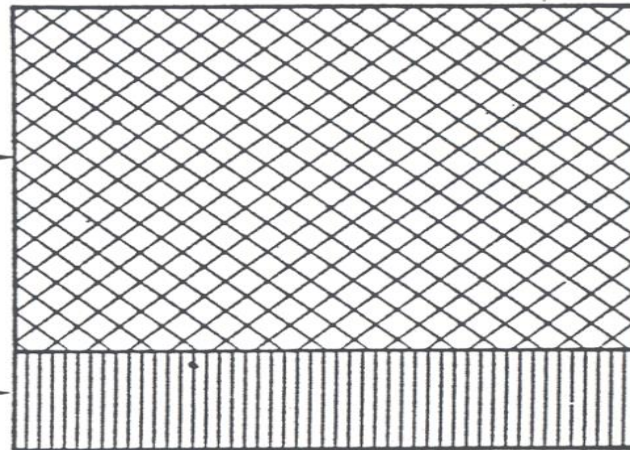

Gram-positive bacterial cell wall

Diagram showing the structure of Gram-negative and Gram-positive bacterial cell walls.



# External Structures of Bacteria

External protrude from the cell into the environment.:

- Flagella
- Pili
- Capsule

# Flagella



- Composed of protein **FLAGELLIN**.
- Helical filaments
- Found in Gram positive & Gram negative bacteria.

## Distribution:

- ~ Peritrichous
- ~ Monotrichous
- ~ Lophotrichous

# Structure of Flagella

**Basal Body** : a protein arranged as rings on central rod (4 ring in Gram negative, 2 ring in Gram positive).

~outer pair of rings: only in Gram negative, pushed through outer membrane.

~ inner pair of rings : inserted into peptidoglycan & cytoplasmic membrane.

**Hook** : bent structure ~act as joint

**Long Filament** : Flagellin protein

**Function of Flagella** : motility & chemotaxis

# Structure & Distribution of Flagella

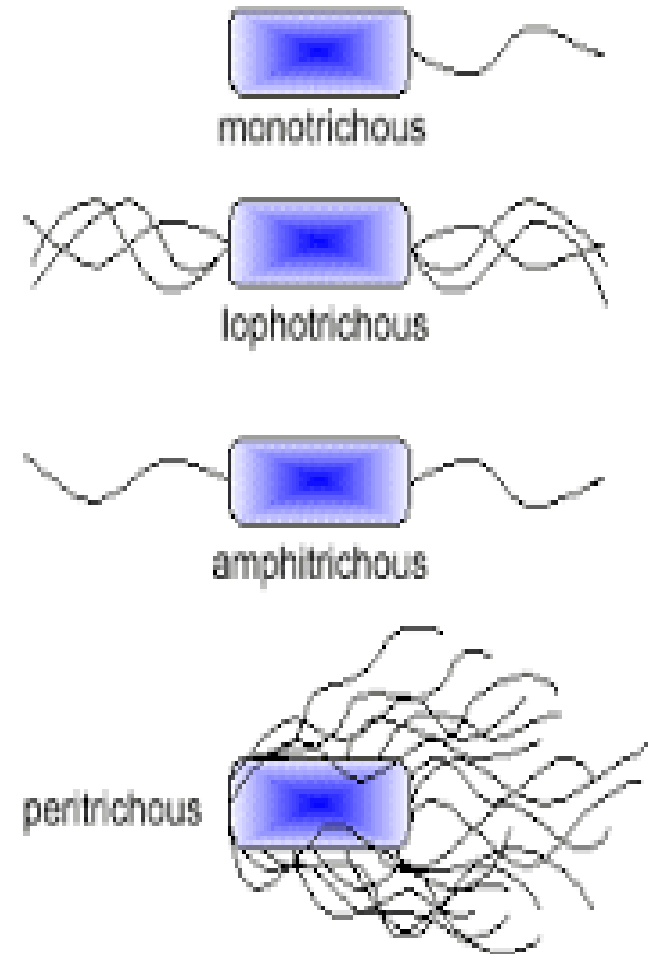
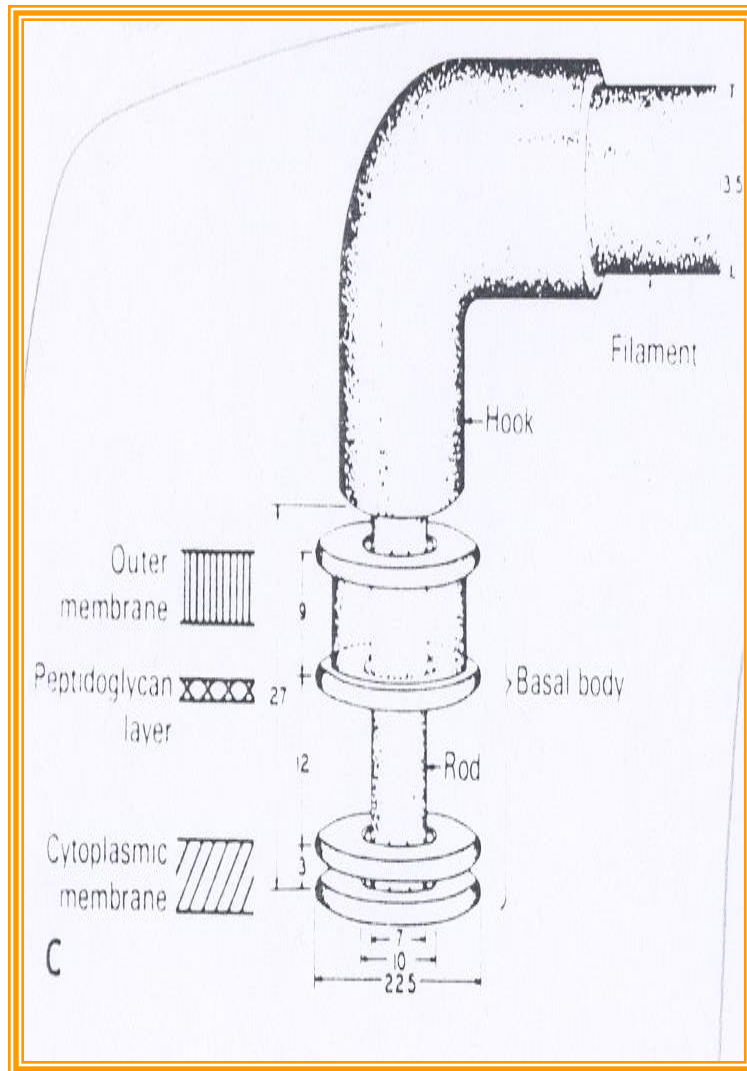

# Pili

Fine short filaments extruding from cytoplasmic membrane.

Found on the surface of many Gram negative & Gram positive bacteria.

Composed of protein Pilin.

## Two classes:

- 1~ **Common pili** (*fimbriae*): covers the surface—  
responsible for: adhesion & colonization
- 2~ **Sex pili** : in some bacteria only, responsible for  
conjugation.

# Capsule

- Amorphous material surrounds bacteria.
- Usually polysaccharide
- Occasionally protein
- **Function** : ~ Inhibits phagocytosis
  - ~ Acts as *Virulence factor* in some bacteria by assisting attachment to the surfaces.

# Cytoplasmic Membrane

- Cytoplasmic membrane (cell membrane)
  - Double layered structure composed of phospholipid & protein
  - Act as semi-permeable membrane (passive diffusion)
  - Site of numerous enzymes involved in active transport of nutrients and various metabolic processes

# Internal Structures of Bacteria

**Mesosomes** : convoluted invaginations of cytoplasmic membrane.

## Function:

- » Involved in DNA segregation during cell division & respiratory activity
- » Contain receptors involved in chemotaxis
- » Permeability barrier (active transport of solutes).



# Core of Bacteria

- Composed of : Cytoplasmic inclusions  
Nucleoid ( nuclear body)  
Ribosome
- 1. Cytoplasmic inclusions:
  - Nutritional storage granules , examples:
    - ~ Volutin
    - ~ Lipid
    - ~ Starch / or Glycogen

# Nucleoid ( Nuclear Body)

- Circular single stranded chromosome (bacteria genome or DNA)
- No nuclear membrane
- DNA undergoes semi-conservative replication , bidirectional from a fixed point
-

# Ribosomes of Bacteria

- Distributed throughout the cytoplasm
- Site of protein synthesis
- Composed of RNA and protein

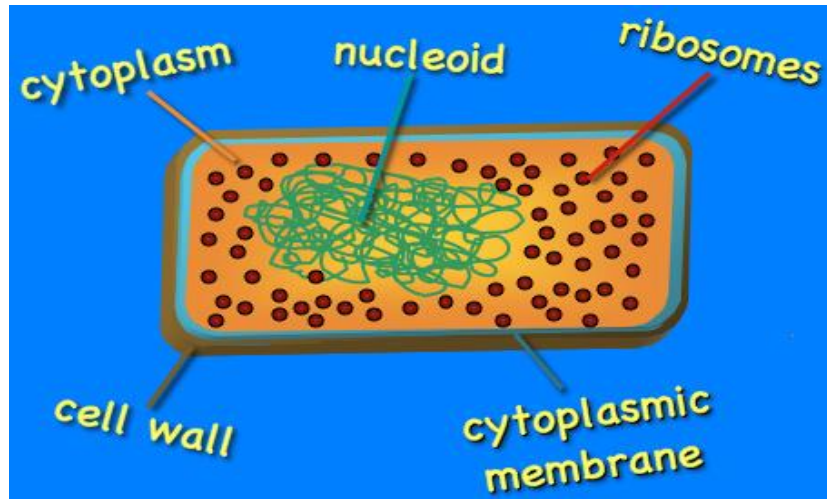

# Spores of Bacteria

- Small ,dense, metabolically inactive , non-reproductive structures produced by *Bacillus* & *Clostridium*
- Enables the bacteria to survive adverse environmental conditions.
- Contain high concentration of Calcium dipicolonate.
- Resistant to heat, dissection & disinfectants
- Often remain associated with the cell wall

# Spores of Bacteria-cont.

- Spores are described as :
  - 1~ Terminal spores
  - 2~ Sub-terminal spores
  - 3~ Central spores
- Spores germinate when growth conditions become favorable to produce vegetative cells.
- Application in medical practice :spore preparations used for checking the efficacy of **Autoclaves**, eg. *Bacillus subtilis & Bacillus sterothermophilus.*

# Spores of Bacteria

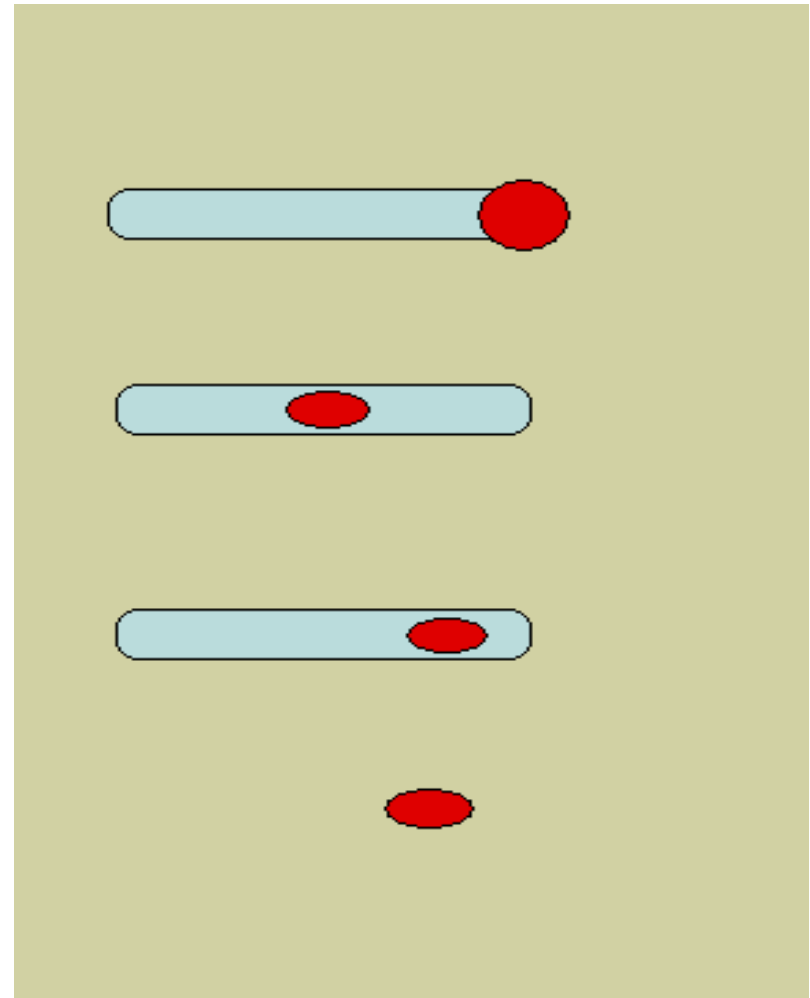
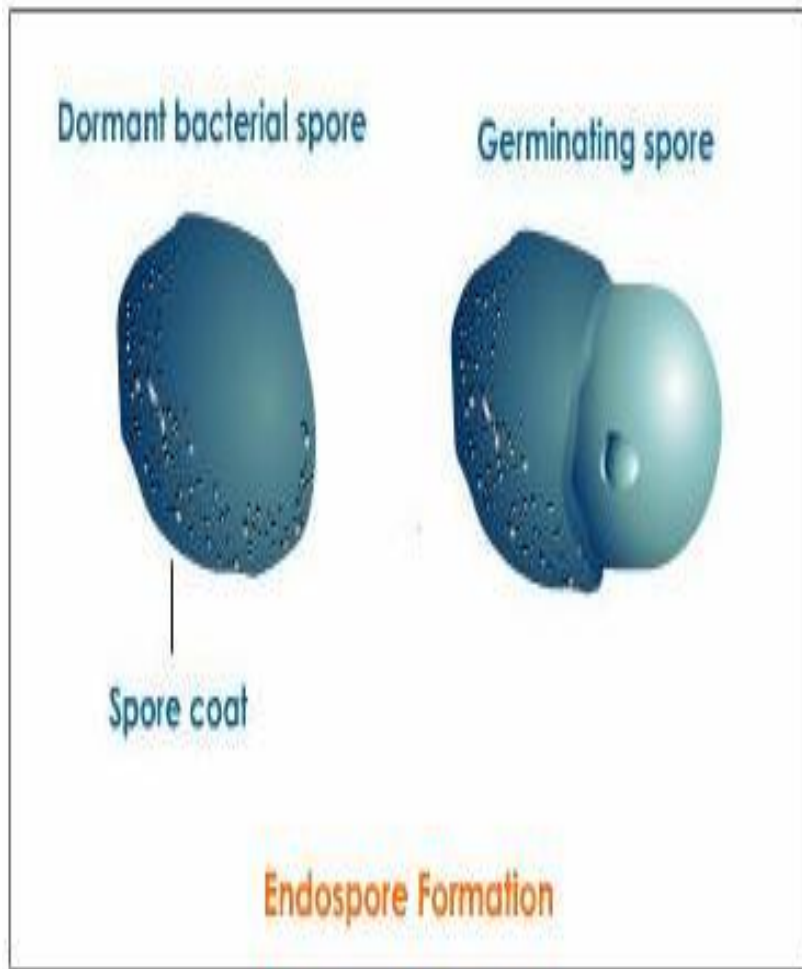



# **BACTERIAL GENETICS**

# Bacterial Genetics- definitions

- **Genetics** is the study of inheritance and variation.
- Genetic information encoded in DNA.

## Function of genetic material:

1~ Replication of the genome

2~ Expression of DNA to mRNA then to protein.



# Definitions-cont.

- **Genotype:** the complete set of genetic determinants of an organism.
- **Phenotype:** expression of specific genetic material .
- **Wild type:** reference (parent) strain~ active.  
**Mutant:** progeny with mutation.

## 2 types of DNA in bacteria

- ~ Chromosomal
- ~ Extra-chromosomal (**Plasmid**).

# Bacterial Chromosomes

- Haploid, circular molecule of double stranded- DNA attached to cell membrane. No nuclear membrane (**prokaryotes**).
- DNA a double helical structure, genetic code in Purine and Pyrimidine bases of nucleotides that makes DNA strand.
- 3 bases comprise one code, each triplet codon codes for one amino acid.
- **Replication is semi-conservative.**

# PROCARYOTES AND EUKARYOTES

## procaryote

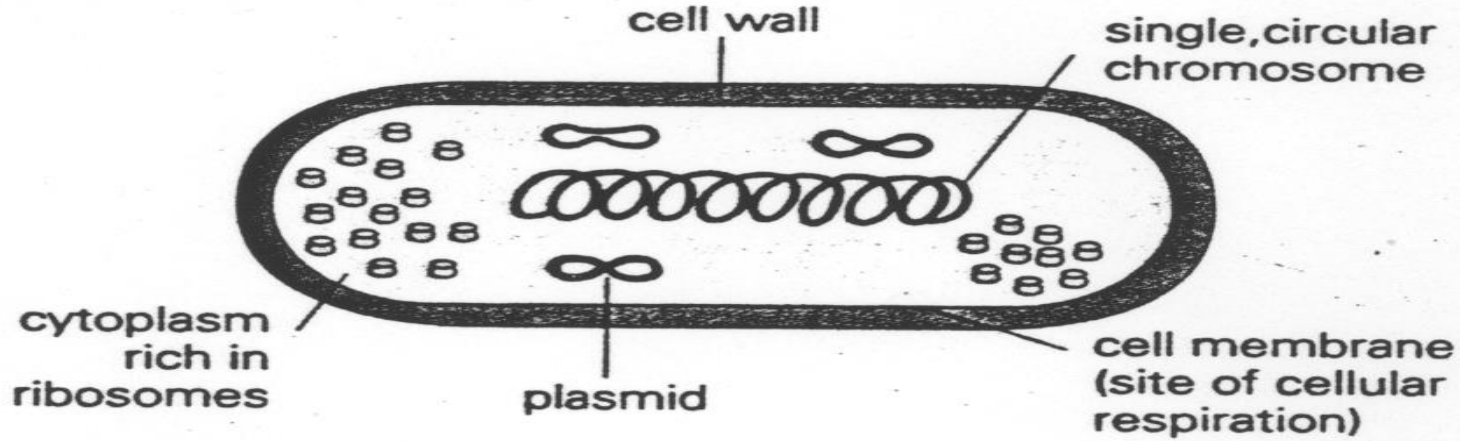

## eucaryote

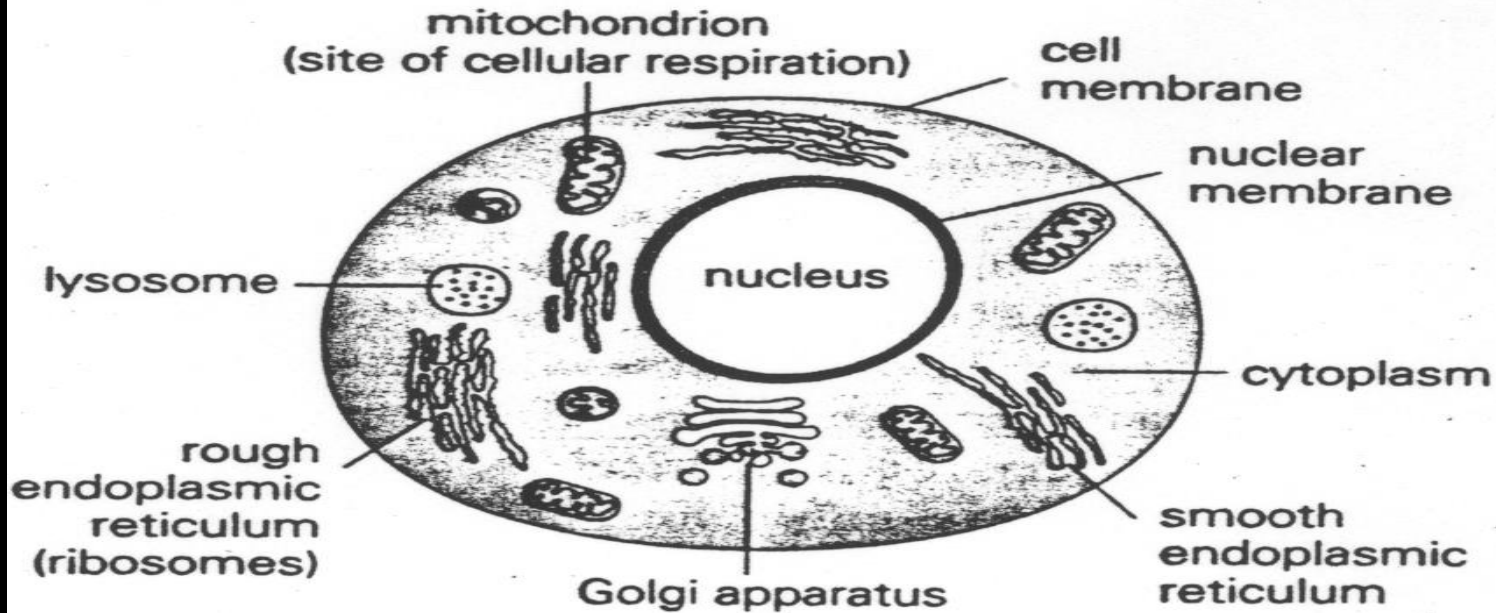

Cytoplasmic membrane

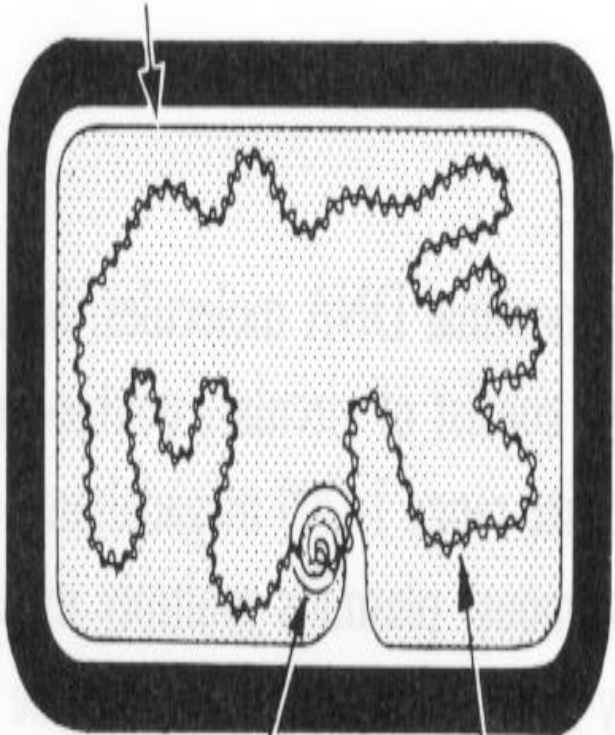

Mesosome Chromosome of circular double-stranded DNA

# Semiconservative Replication

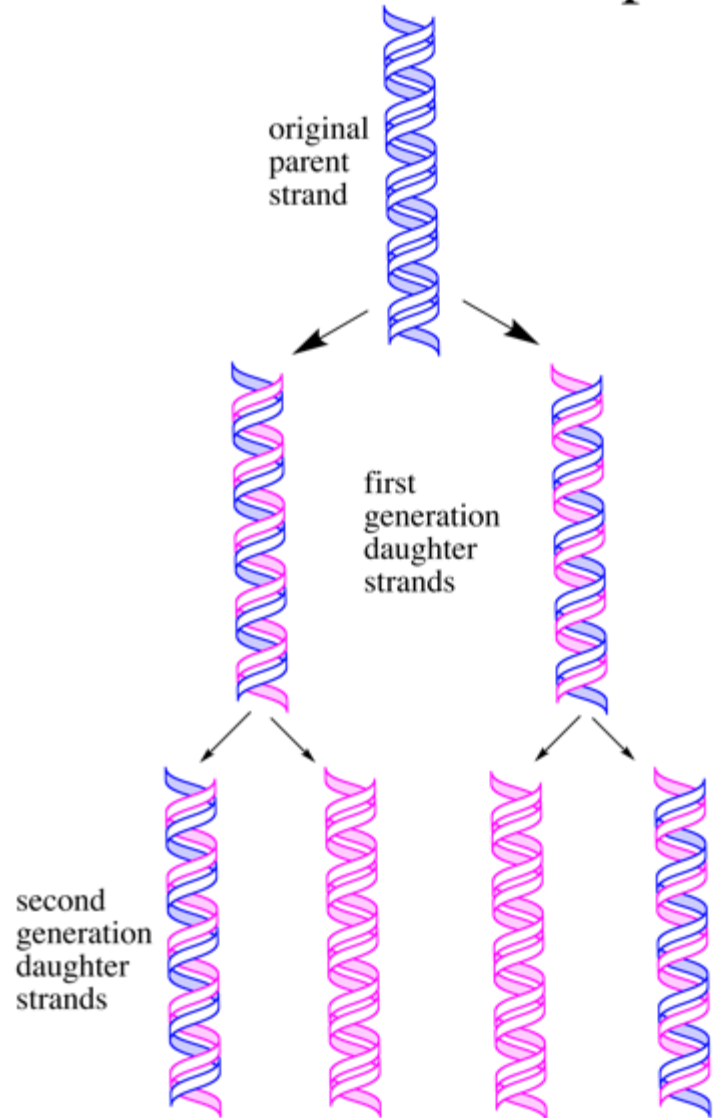

# Plasmids

- Extra chromosomal DNA composed of double stranded-DNA.
- Found in most species of bacteria.
- Origin?
- Govern their own replication
- **Application** :Genetic exchange, amplify genes
- Transfer by conjugation
- Unrelated plasmids coexist together only

# Plasmids

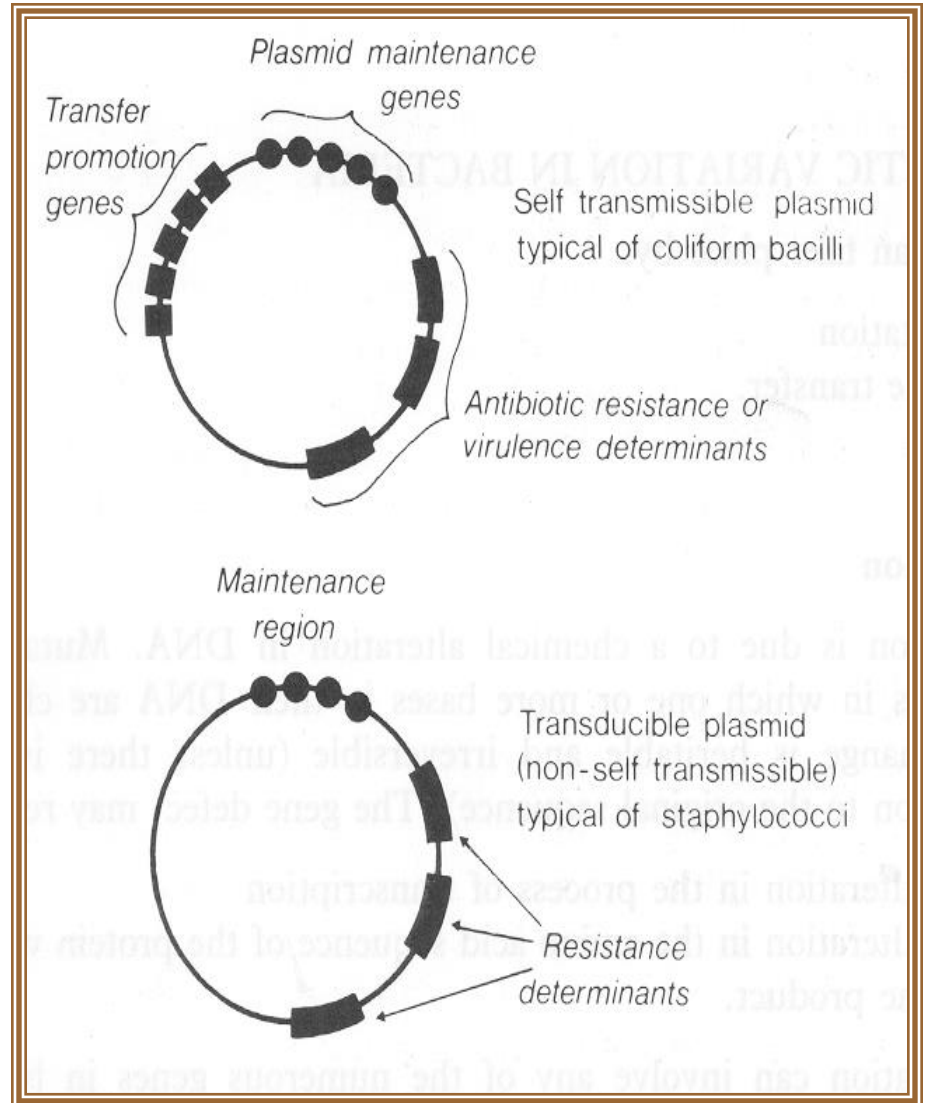
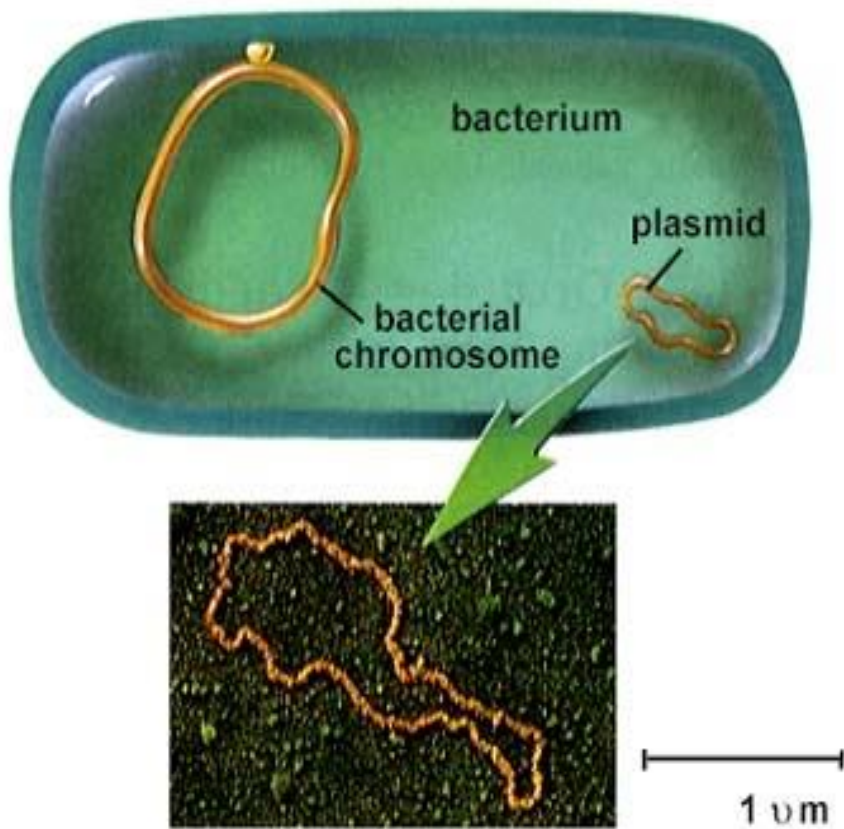

# Types of Plasmids

- 1~ **R-plasmids**: genes code for antibiotic resistance particularly Gram negative bacteria.
- 2~ **Col-plasmids**: in Enterobacteria, codes for extracellular toxins.
- 3~ **F-plasmids**: (fertility) factor, transfer of chromosome during mating .

Genetic variation in bacteria :

takes place by :

1~ Mutations

2~Gene transfer



# Mutation

- Inheritable changes in the structure of genes (DNA).
- Chemical changes in one or more bases of DNA.

Mutation / gene defect leads to alteration in:

- Transcription,
- Amino acid sequence,
- Function eg. **Bacteria resistant to antibiotic.**

# Classification of Mutation

Depends on biological sequencing:

1- **Resistance mutation**: affect structure of cell protein. Main application in medical practice.

Bacteria become resistant to antibiotics

2- **Auxotrophic mutation**: affect biosynthetic enzyme resulting in a nutritional requirement of mutant cell.

3- **Lethal mutation**.

# Mutation Causes Antimicrobial Resistance

## Genetic Mutation Causes Drug Resistance

Non-resistant bacteria exist

Bacteria multiply by the billions

Some mutations make the bacterium drug resistant

Drug resistant bacteria multiply and thrive.

A few of these bacteria will mutate.

In the presence of drugs, only drug resistant bacteria survive.

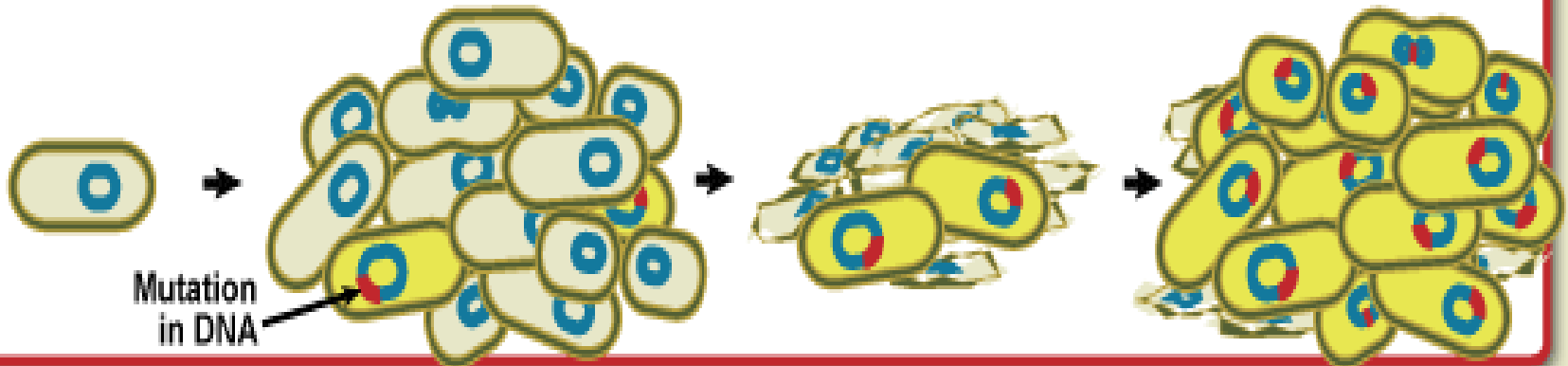

# Gene Transfer Among Bacteria

## Three mechanisms:

- 1~ Transformation
- 2~ Transduction
- 3~ Conjugation.

## Mechanisms of Gene Exchange

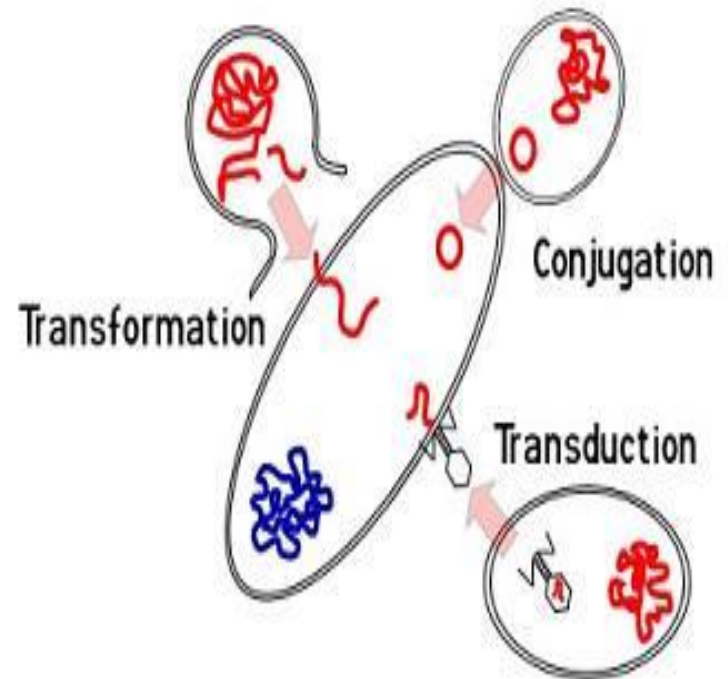

# Transformation

- A fragment of exogenous naked bacterial DNA are taken up and absorbed into recipient cells.
- Common in *Haemophilus influenzae* & *Streptococcus pneumoniae*. **Bacteria become resistant to Ampicillin.**

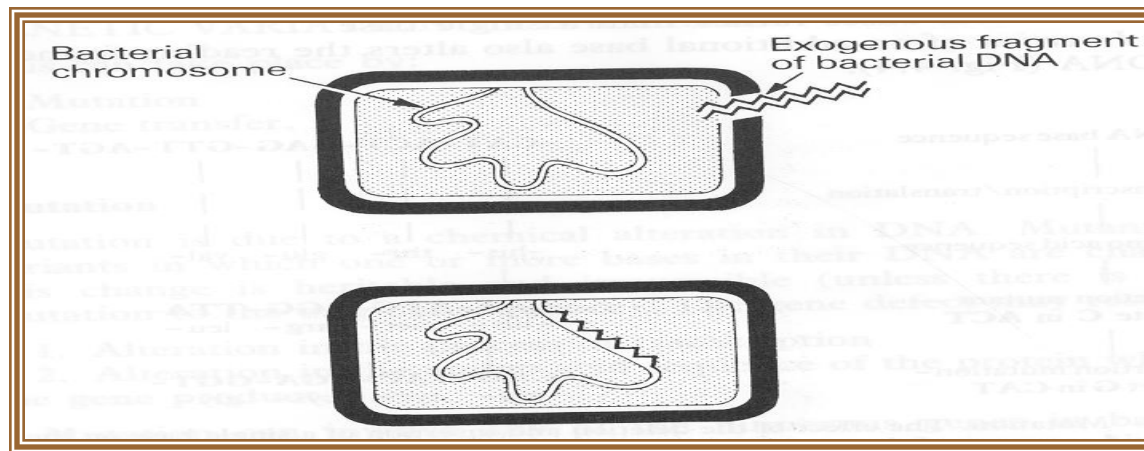

# Transduction

- Phage mediated transfer of genetic information from donor to recipient cells.

## Example:

- Beta – Lactamase production in *Staphylococcus aureus* : **Bacteria becomes resistant to penicillin.**
- Toxin production in *Corynebacterium diphtheriae*.

# Transduction

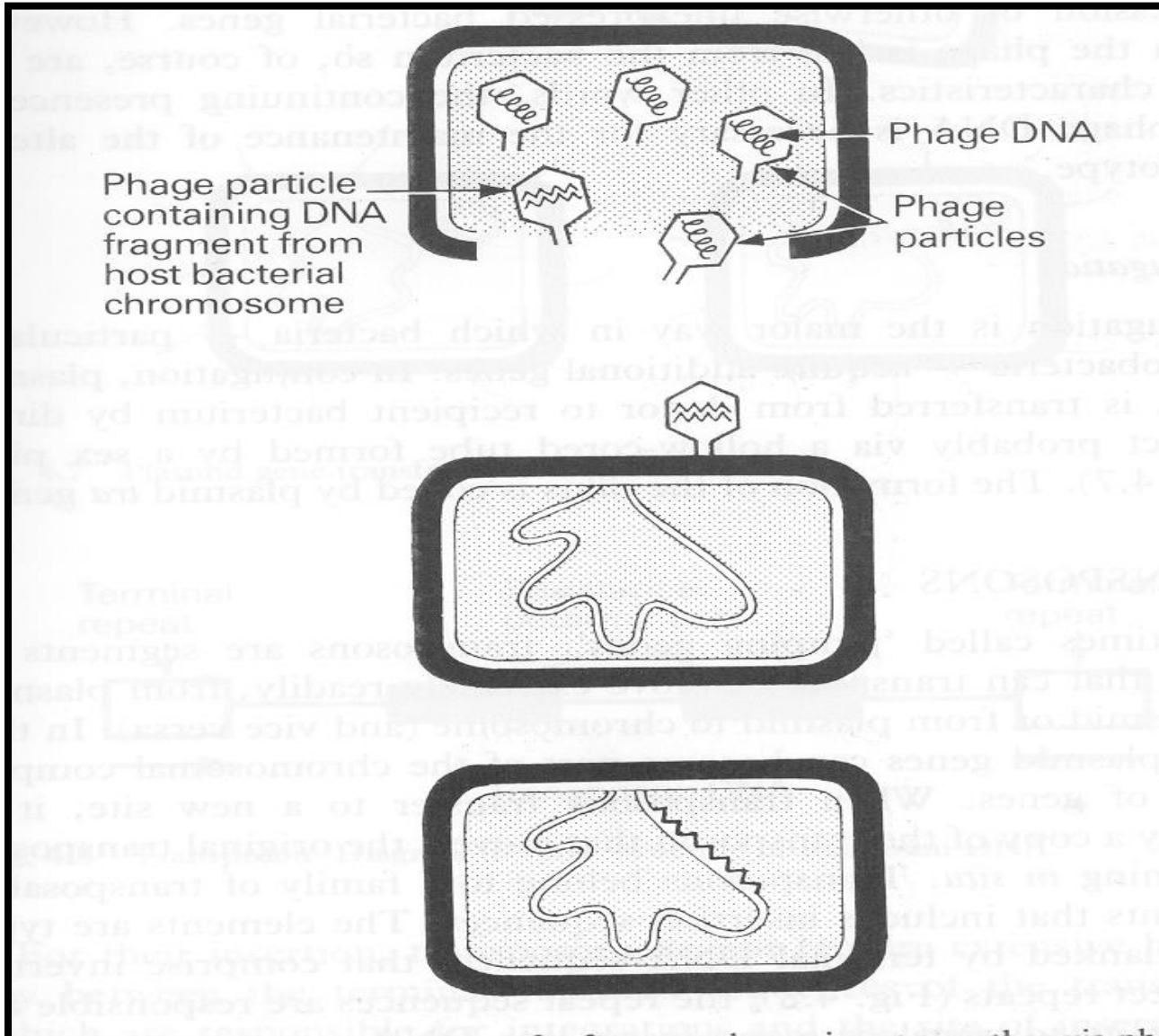

# Conjugation

- Major way bacteria acquire additional genes.
- Plasmid mediated
- Cell contact required and genes reside on plasmid resident within donor cells transfer to recipient cell (**mating**).
- **Conjugation is the common way of transfer of genes resistance to antibiotics among bacteria in hospitals.**



# Conjugation

- Mediated by plasmid called **F factor** (fertility).
- Gene encode changes in surface by producing a **sex pilus** .this facilitates capture of  $F^-$  cells and the formation of a conjugation bridge through which DNA passes from  $F^+$  into  $F^-$  cells.

•

# Conjugation in Bacteria

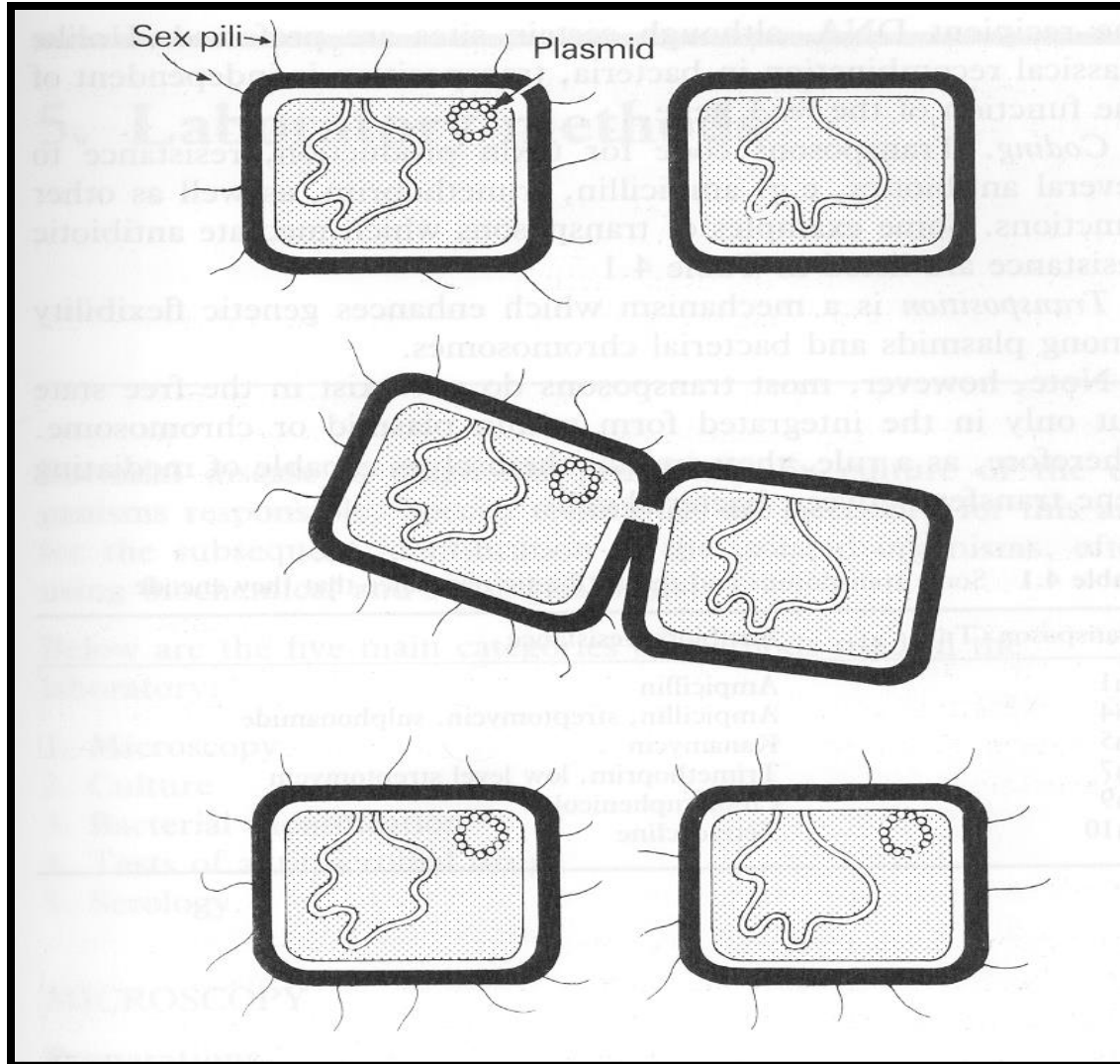

# Genetic Recombination

After gene transfer, there are three possible fates:

1~Exogenous DNA degraded by nuclease.

2~Stabilized by circulization and become plasmid.

3~ Form a partially hybrid chromosome with segment derived from each source.

# Transposable Elements

- Genetic units capable of mediating own transfer from chromosome to another, from location to other on same chromosome or between plasmid and chromosome or phage DNA.
- Types: 1~ Transposons .  
2~ Insertion sequence

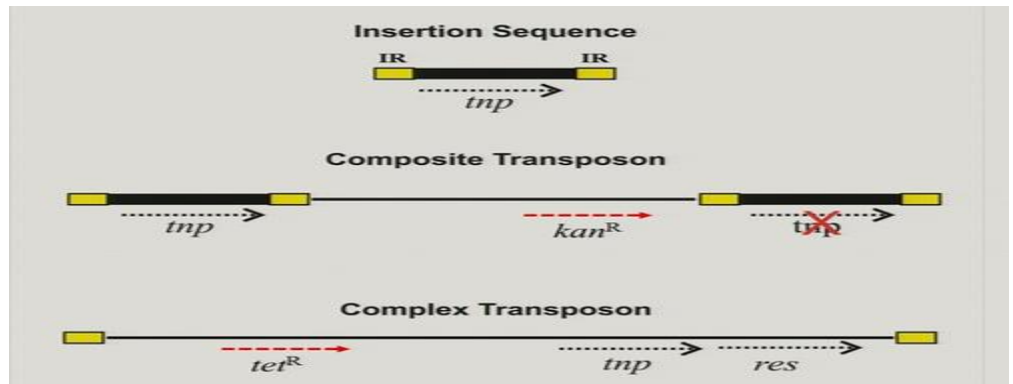

# Reference Book

*Sherries Medical Microbiology, an Introduction to Infectious Diseases.*

Latest edition, Kenneth Ryan and George Ray.  
Publisher : McGraw Hill .

**Chapter 2** : page 11~25, **Chapter 4**: page 53~75 .