

**Applied Nerve & Muscle
Physiology:
Nerve Conduction Study (NCS) and
Electromyography (EMG)**

Dr. Salah Elmalik

Objectives

At the end of the lecture student should be able to:

- Define nerve conduction study (NCS) and electromyography (EMG) .
- Explain the procedure of NCS
- Define the normal conduction velocity in upper limb and lower limb nerves .
- Define the motor unit potentials (MUPs) and how they are changed in muscle and nerve diseases .

Nerve Conduction studies

- A nerve conduction study (NCS) is a test commonly used to evaluate the function, especially the ability of electrical conduction, of the motor and sensory nerves of the human body.
- Nerve conduction velocity (NCV) is a common measurement made during this test.

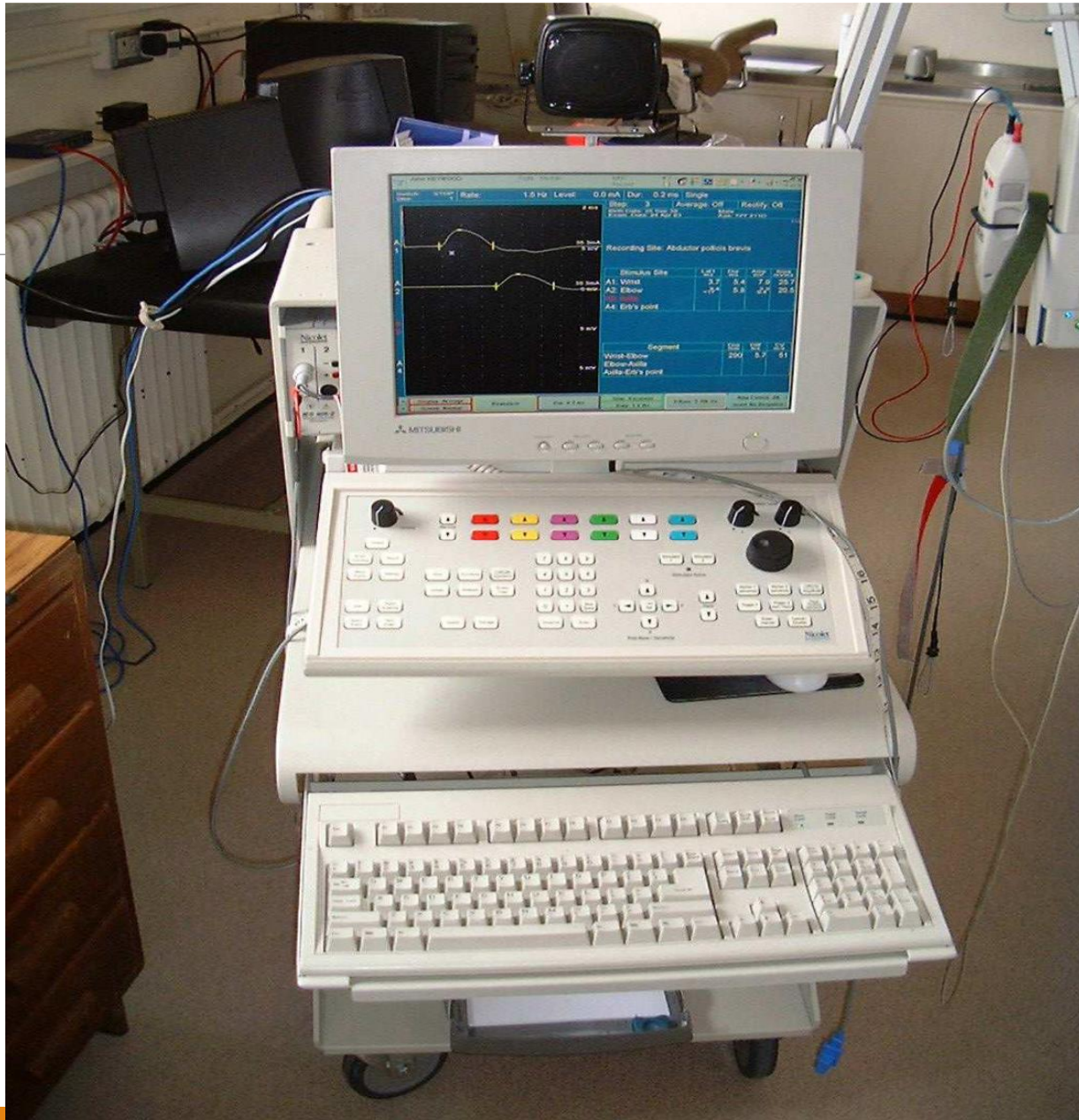

Nerve Conduction Studies

- Standard nerve conduction studies typically include motor nerve conduction, sensory nerve conduction.
- Sensory and motor nerve conduction studies involve analysis of specific parameters, including latency, conduction velocity, and amplitude.

Motor nerve conduction velocity

- Motor nerve conduction velocity of peripheral nerves may be closely correlated to their functional integrity or to their structural abnormalities.
- Based on the nature of conduction abnormalities two principal types of peripheral nerve lesions can be identified: *Axonal degeneration and segmental demyelination.*

Motor Conduction Studies

- The *CMAP* is a biphasic potential with an initial upward deflection from the baseline
- For each stimulation site : the latency, amplitude, duration, of the *CMAP* are measured .
- A motor conduction velocity can be calculated after two sites of stimulation, one distal and one proximal.

CMAP

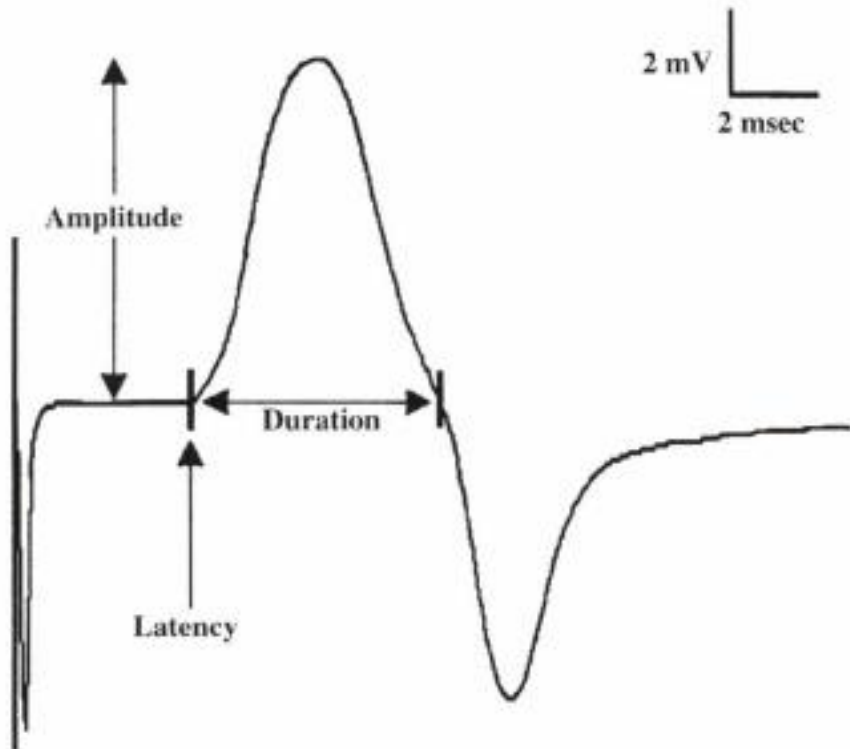

MCS Procedure

- The active recording electrode is placed on the center of the muscle belly (over the motor endplate), and the reference electrode is placed distally about 3-4 cm
- The stimulator then is placed over the nerve that supplies the muscle.

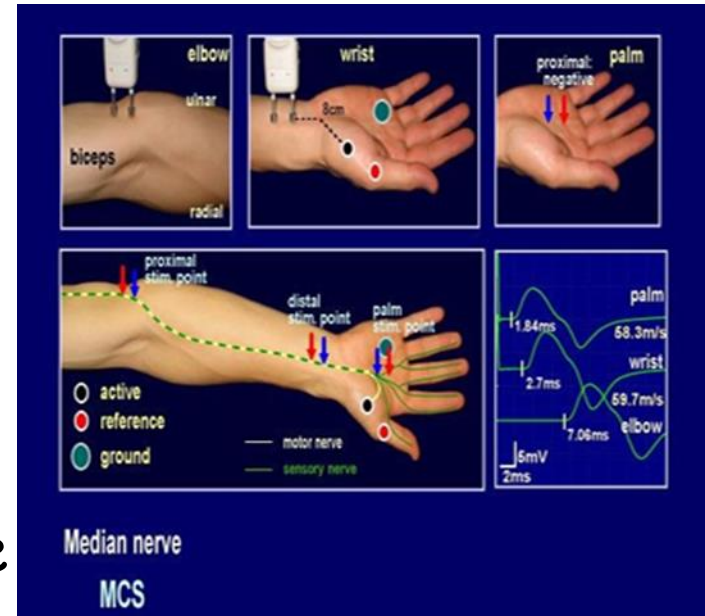

Cont.

- As current is slowly increased from a baseline: more of the underlying nerve fibers are brought to action potential, and subsequently more muscle fiber action potentials are generated.
- most nerves require a current in the range from 20 to 50 mA to achieve supramaximal stimulation.

- The recorded potential, known as the *compound muscle action potential (CMAP)*, represents the summation of all underlying individual muscle fiber action potentials.
- When the current is increased to the point that the CMAP no longer increases in size, one presumes that all nerve fibers have been excited and that supramaximal stimulation has been achieved. The current then is increased by another 20% to ensure supramaximal stimulation.

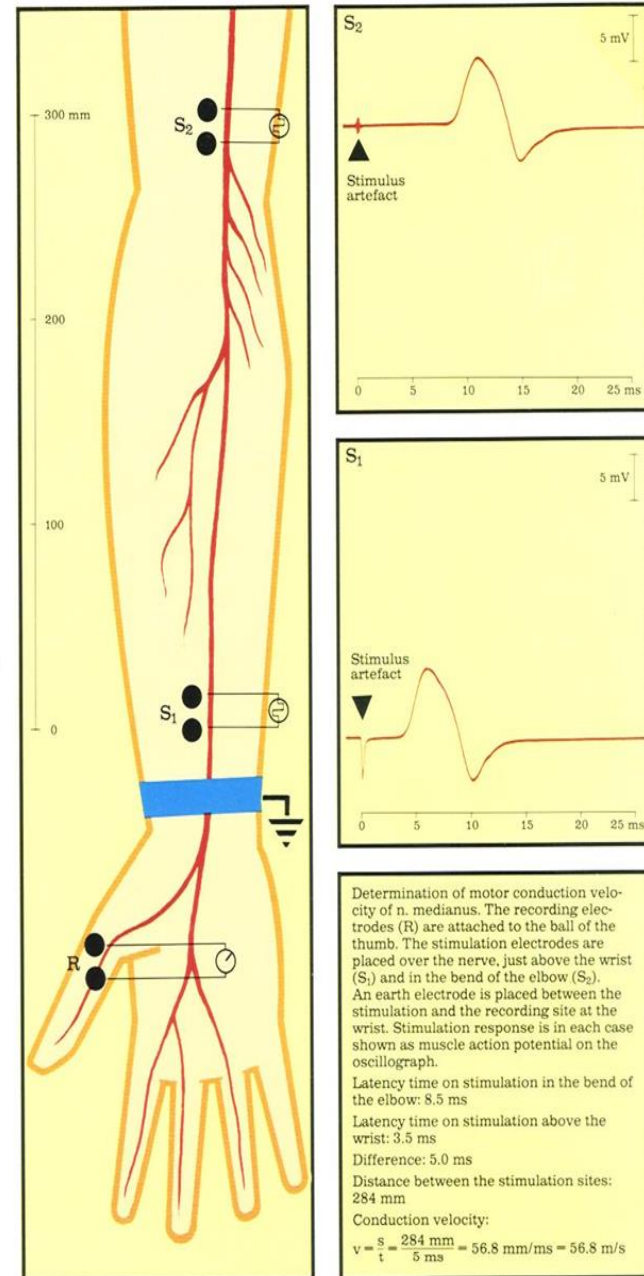

Conduction Velocity

- It's measurement of the speed of the conducting nerve axons
- It is calculated by dividing the distance (between proximal stimulation site & distal stimulation site in mm) by the change in time (proximal latency in msec minus distal latency in ms)

Conduction Velocity

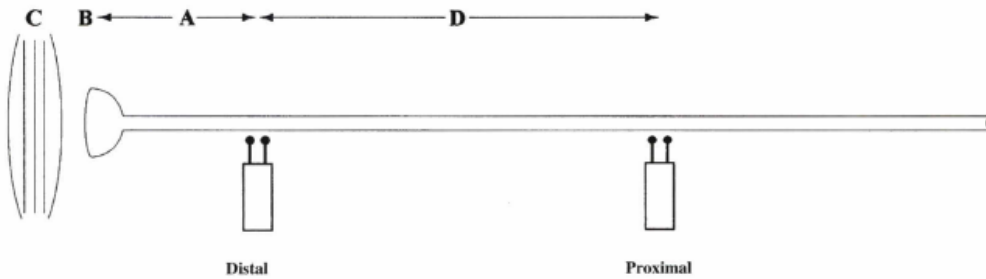
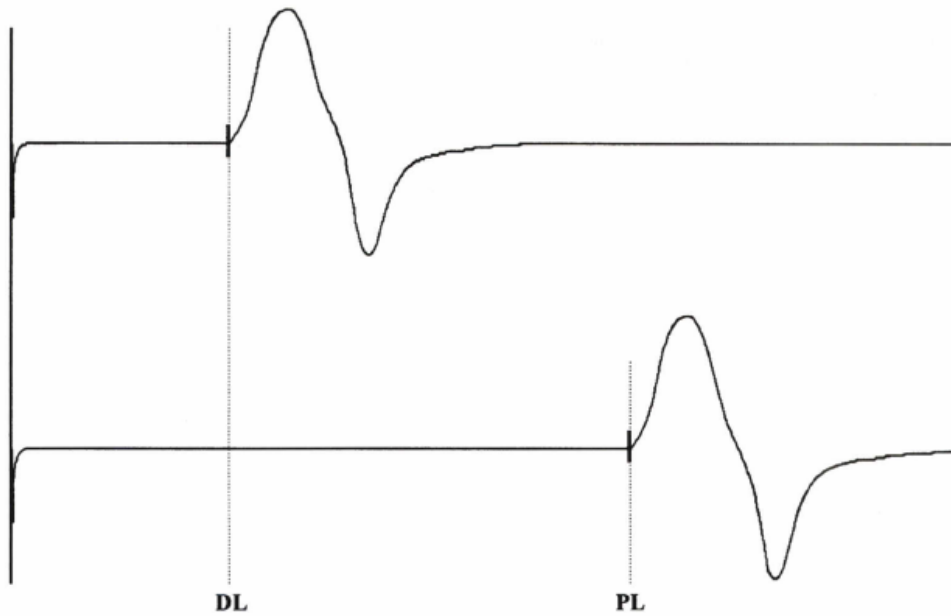

MOTOR NERVE CONDUCTION VELOCITY (MNCV)

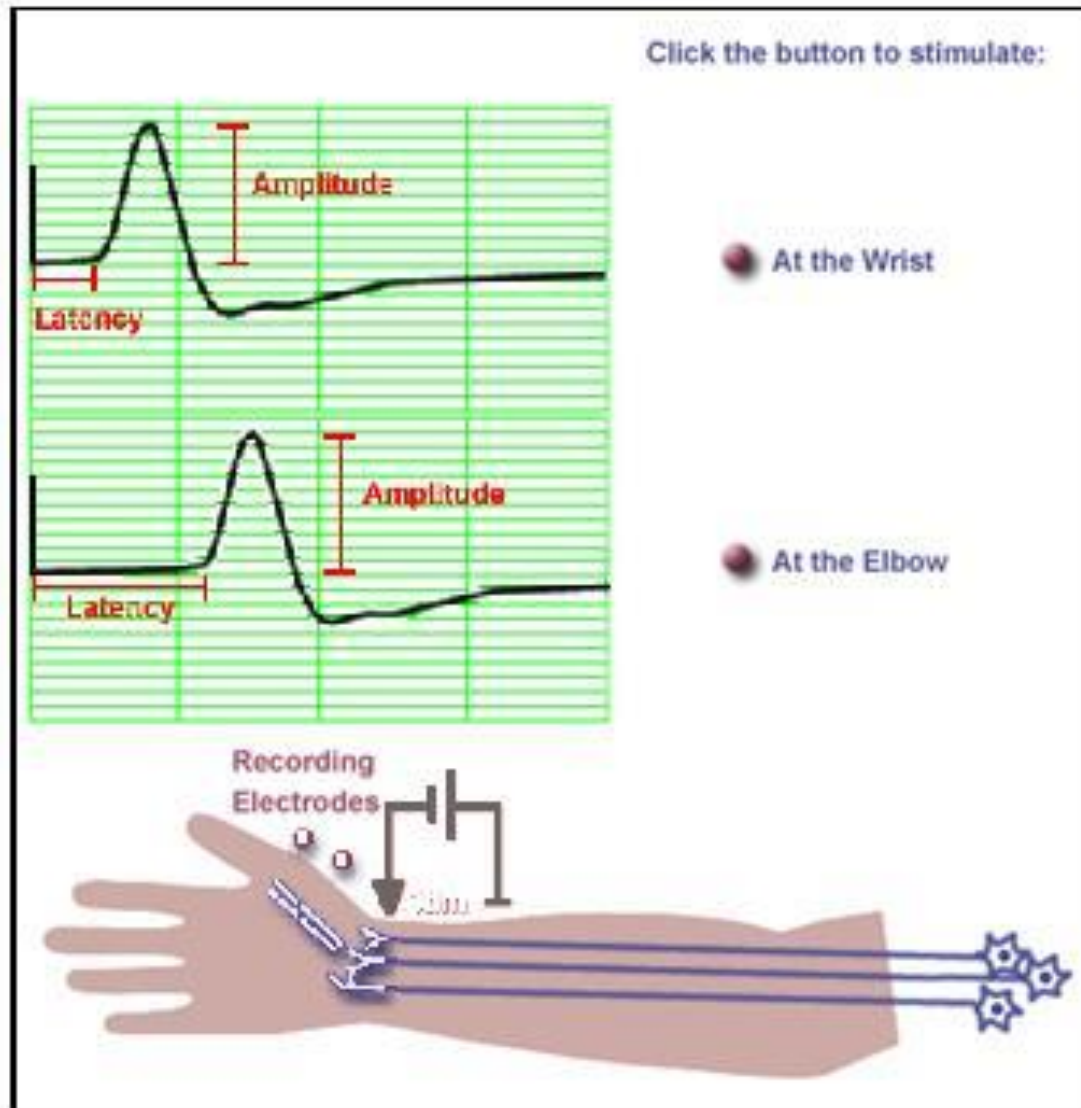

Normal values for conduction velocity

✓ In arm

50 - 70 m / sec.

✓ In leg

40 - 60 m / sec.

LATENCY

- Latency measurements usually are made in milliseconds (ms).
- The latency is the time from the stimulus to the initial deflection from baseline

Amplitude

- **it is most commonly measured from baseline to the peak (baseline-to-peak) and less commonly from the first upward peak to the next downward peak (peak-to-peak).**
- **CMAP amplitude reflects the number of muscle fibers that depolarize.**
- **low CMAP amplitudes most often result from loss of axons (as in a typical axonal neuropathy)**
- **average CMAP amplitude 3 mv**

Duration

- This is measured from the initial deflection from baseline to the final return
- Duration characteristically increases in conditions that result in *slowing of some motor fibers (e.g., in a demyelinating lesion)*.

MNCV

MNCV can also be calculated by formula

$$\text{MNCV (m/sec)} = \frac{\text{Distance (mm)}}{L_1 - L_2 \text{ (msec)}}$$

l_1 = latency at elbow.

l_2 = latency at wrist

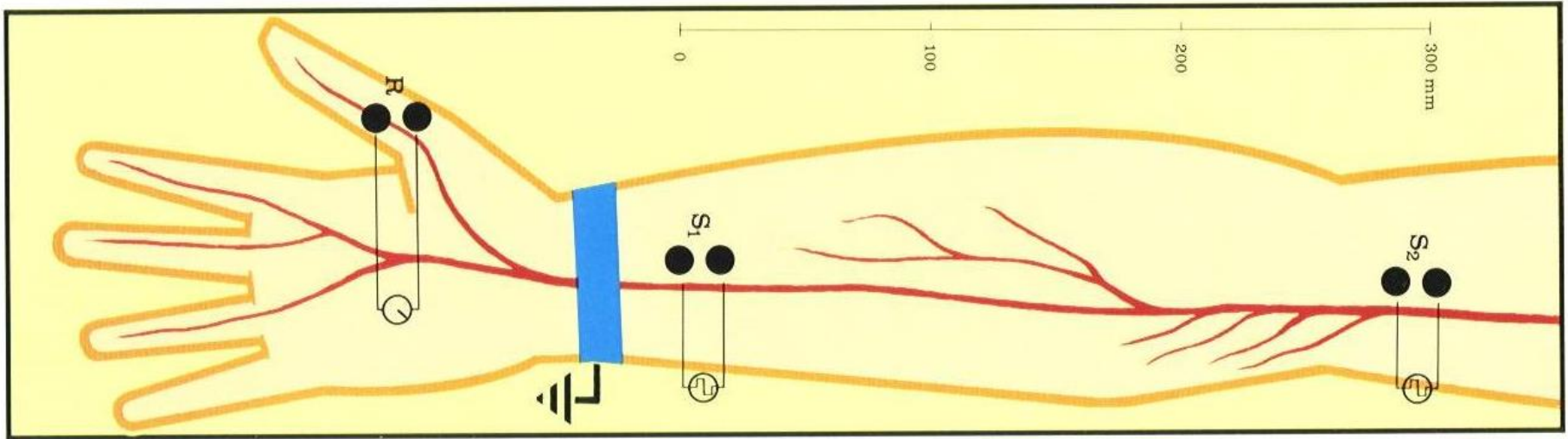

Distance

$d = 284 \text{ mm}$

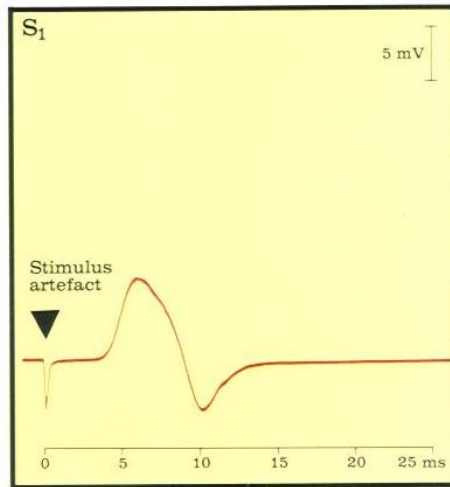

Latency At wrist

$L_2 = 3.5 \text{ ms}$

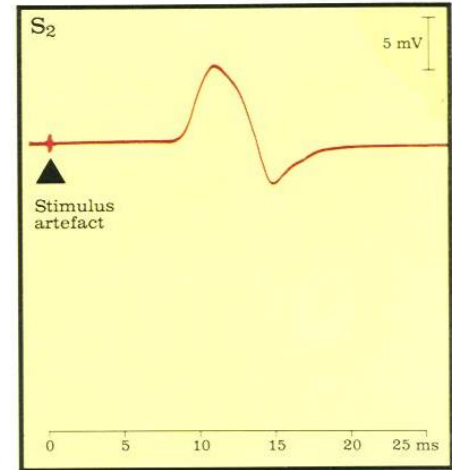

Latency At elbow

$L_1 = 8.5 \text{ ms}$

Patterns of Nerve Conduction

Normal study of Median Nerve:

- *Note the normal median distal latency (DL) 3 ms, amplitude >4 mV, and conduction velocity (CV) >49 m/s.*

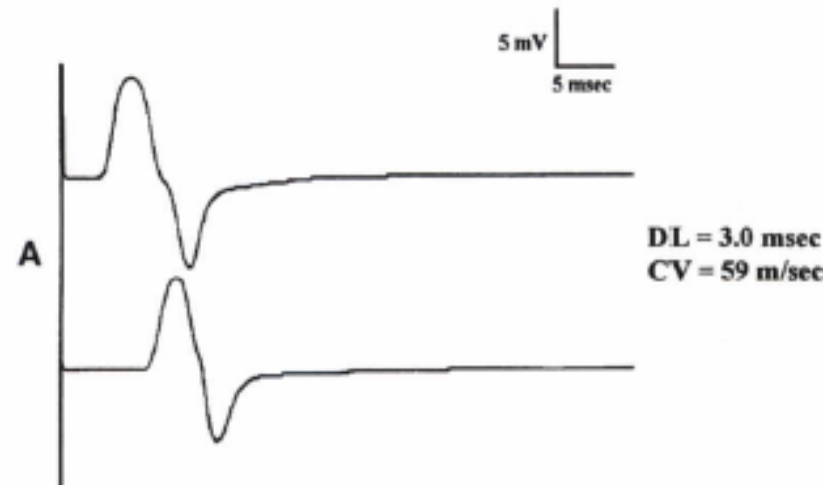



Axonal loss

- Amplitudes decrease
- CV is normal or slightly slowed.
- DL is normal or slightly prolonged.
- The morphology of the potential does not change between proximal and distal sites.

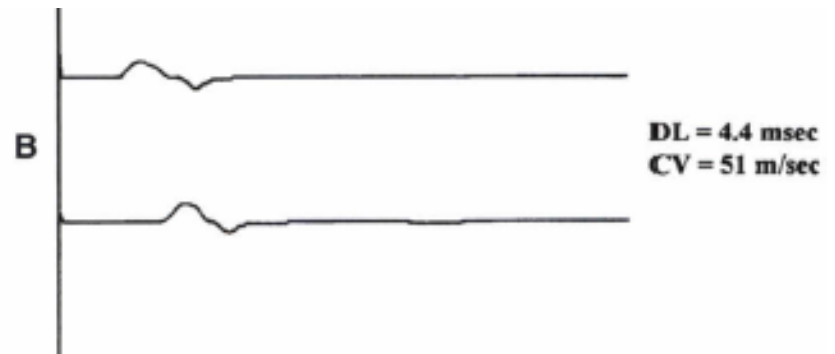

Demyelination associated with inherited disorders

- CV is markedly slowed < 75% lower limit of normal)
- DL is markedly prolonged (>130% upper limit of normal).
- However, there usually is no change in configuration between proximal and distal stimulation

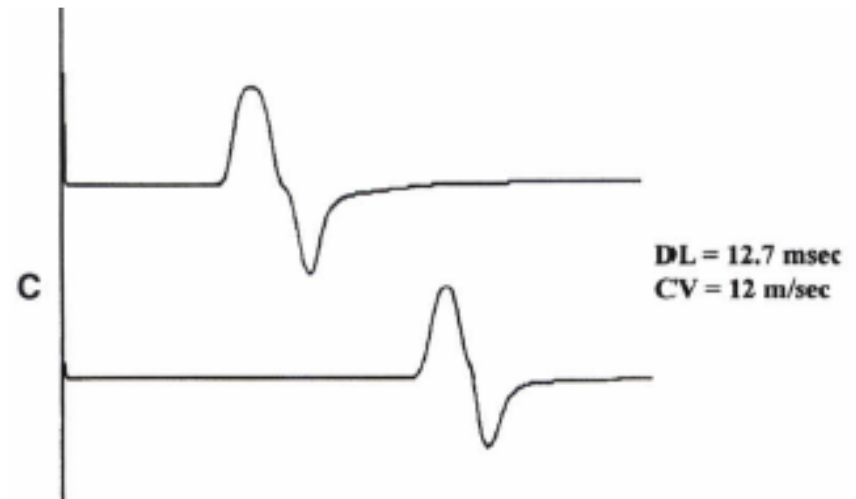

Axonal degeneration neuropathy features

- Low amplitudes
- Normal / slight delay in latency
- Normal / slightly low conduction velocity

Demyelinating Neuropathy features

- Normal amplitudes
- Significant delay in latency
- Significantly low conduction velocity

ELECTROMYOGRAPHY (EMG)

- It's a recording of electrical activity of the muscle by inserting needle electrode in the belly of the muscles or by applying the surface electrodes.
- The potentials recorded on volitional effort are derived from motor units of the muscle, hence known as motor unit potentials (MUPs).

- A motor unit is defined as one motor neuron and all of the muscle fibers it innervates.

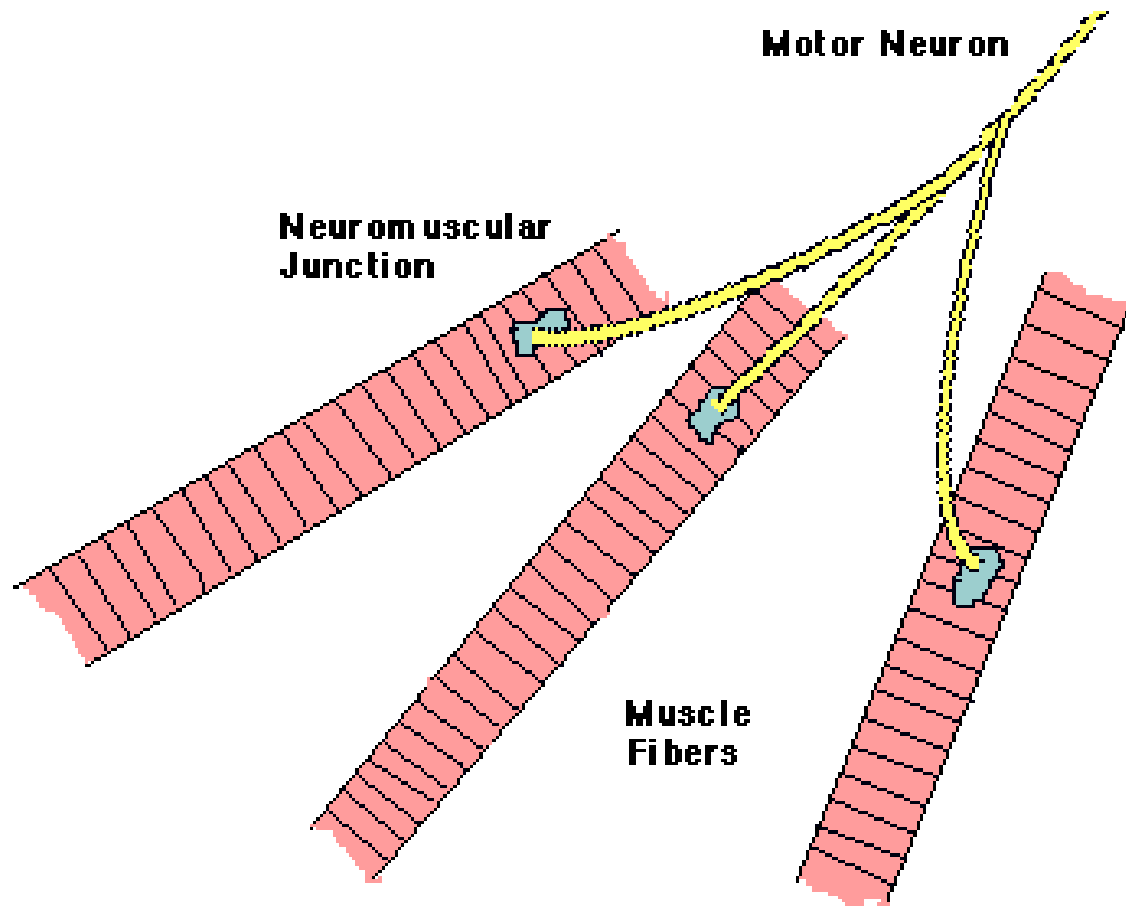

One Motor Unit

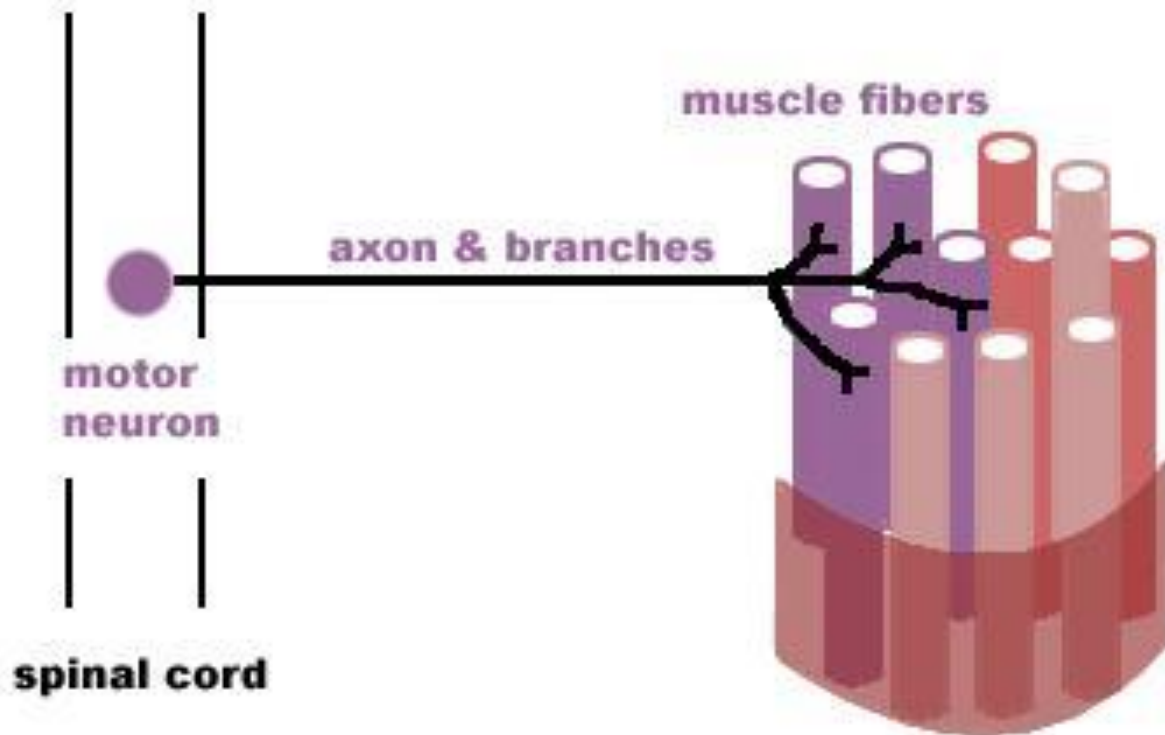

Analysis

Insertional activity

The electrical activity present as the electrode is passed through muscle cells. These are discharge potentials provoked by the disruption of the cell membrane itself.

- ✓ -decreased in atrophied muscle or fatty tissue.
- ✓ - increased in many abnormal conditions that cause membrane instability, such as neuropathies, radiculopathies, and inflammatory myopathies.

Spontaneous activity

- The skeletal muscle is silent at rest, hence spontaneous activity is absent.

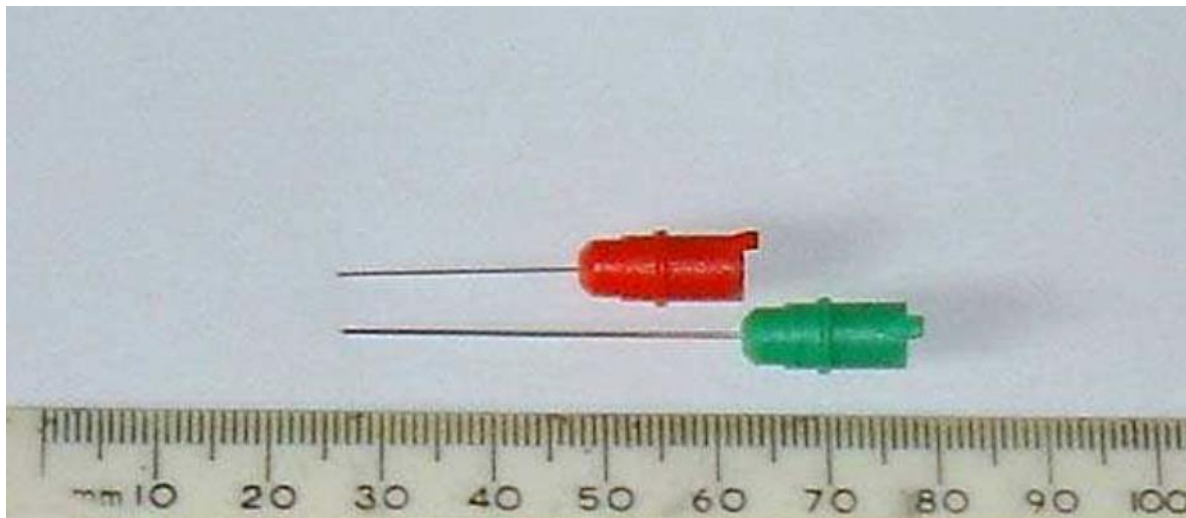

Normal MUPs

- Morphology: Bi - Triphasic
- Duration - 3 - 15 mSec.
- Amplitude - 300 μ V - 5 mV

MUPs (2)

During Mild Effort

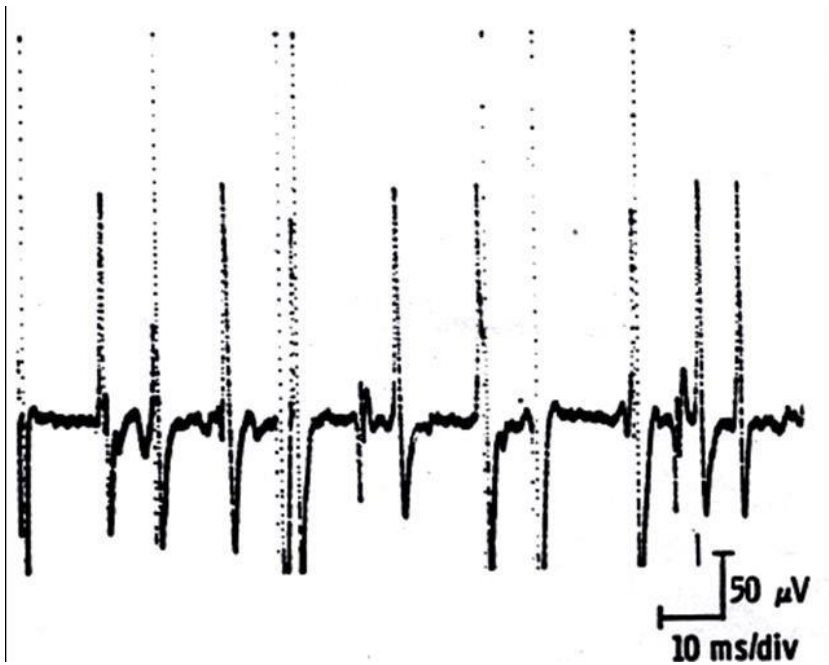

During Moderate Effort \rightarrow note recruitment of additional motoneurons

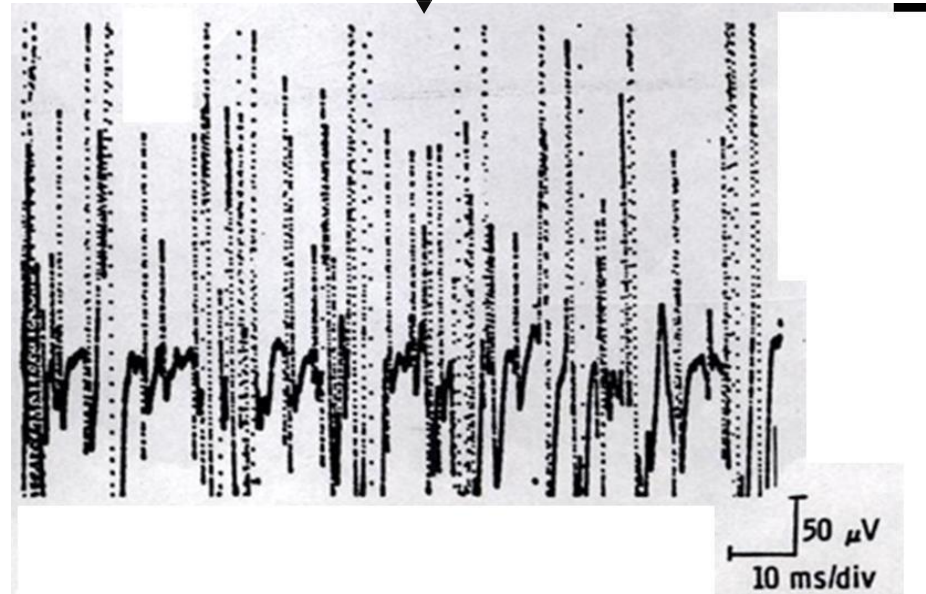

During Full Voluntary Effort .
There is full recruitment
(you
can not see the baseline)

Normal Muscle

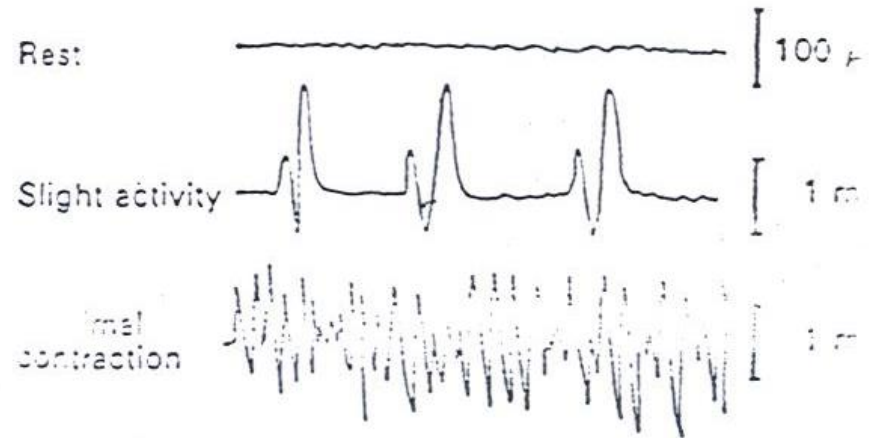
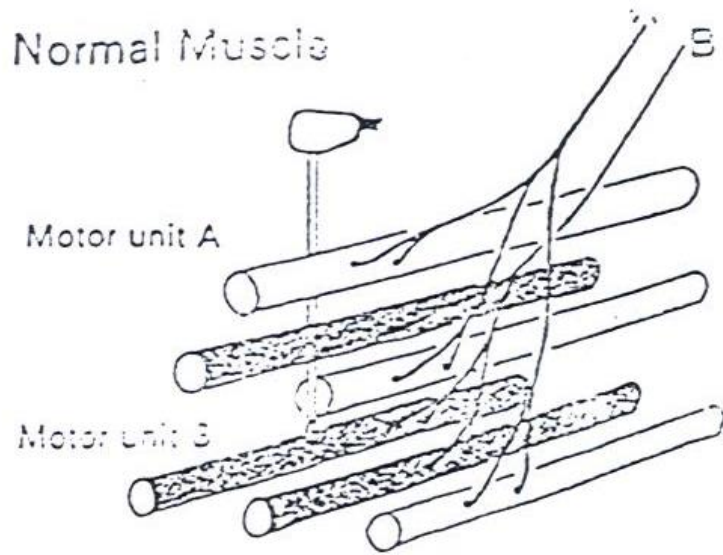

NORMAL EMG

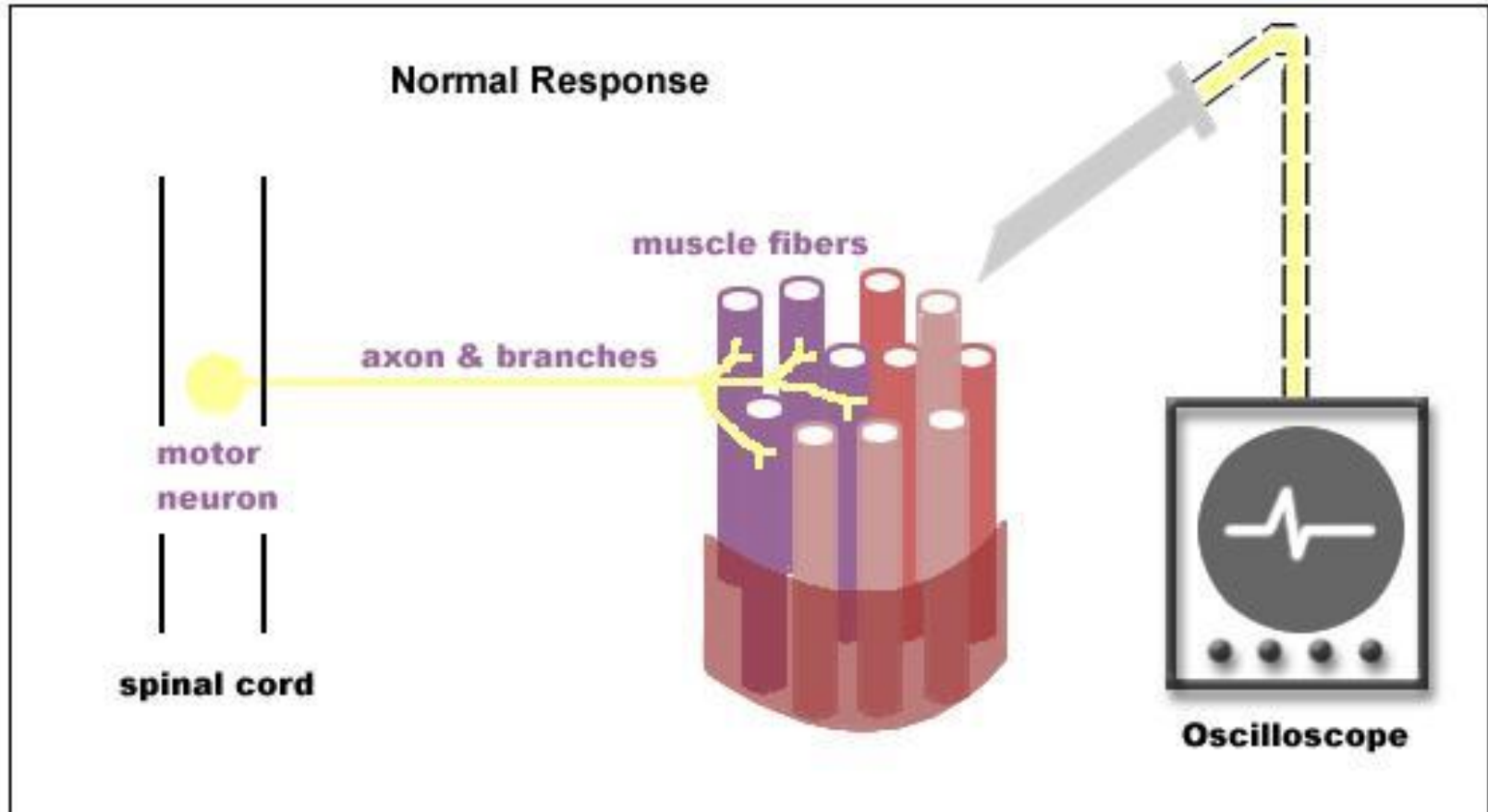

Abnormal MUPs

- ❑ Presence of resting activity in form of:
 - ❑ **1- Positive sharp wave:**
 - ❑ A small potential of 50 to 100 μV , 5 to 10 msec duration with abrupt onset and slow outset. It is the earliest manifestation of axonal denervation .
 - ❑ Fibrillations are not found exclusively in neurogenic disease, however; they also occur in inflammatory and dystrophic muscle disease.

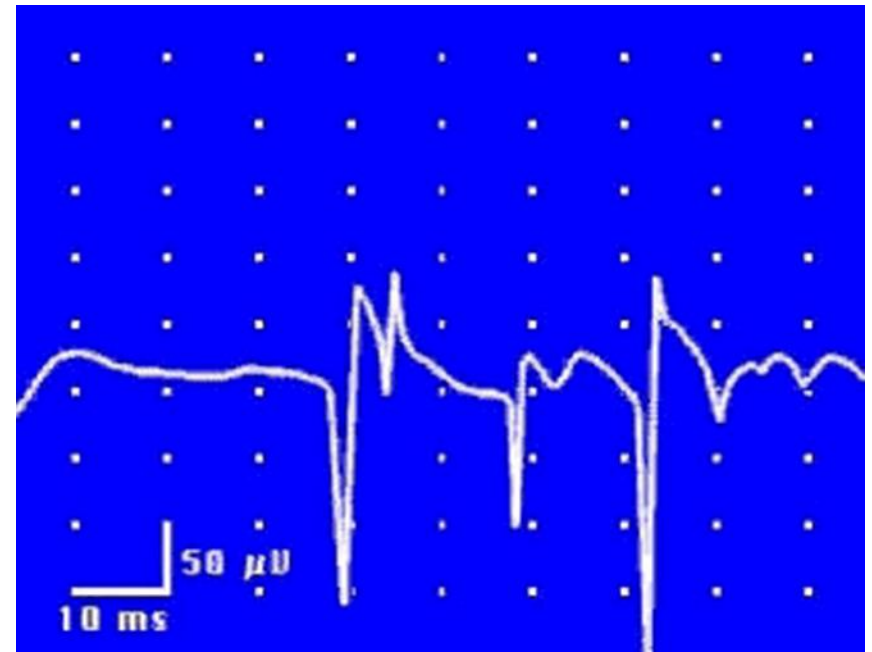

Cont...

□ 2- Fibrillation potential:

- These are randomly occurring small amplitude potentials or may appear in runs. The audioamplifier gives sounds, as if somebody listen sounds of rains in a tin shade house. These potentials are generated from the single muscle fiber of a denervated muscle, possibly due to denervation hypersensitivity to acetyl choline.
- They are not visible through the skin

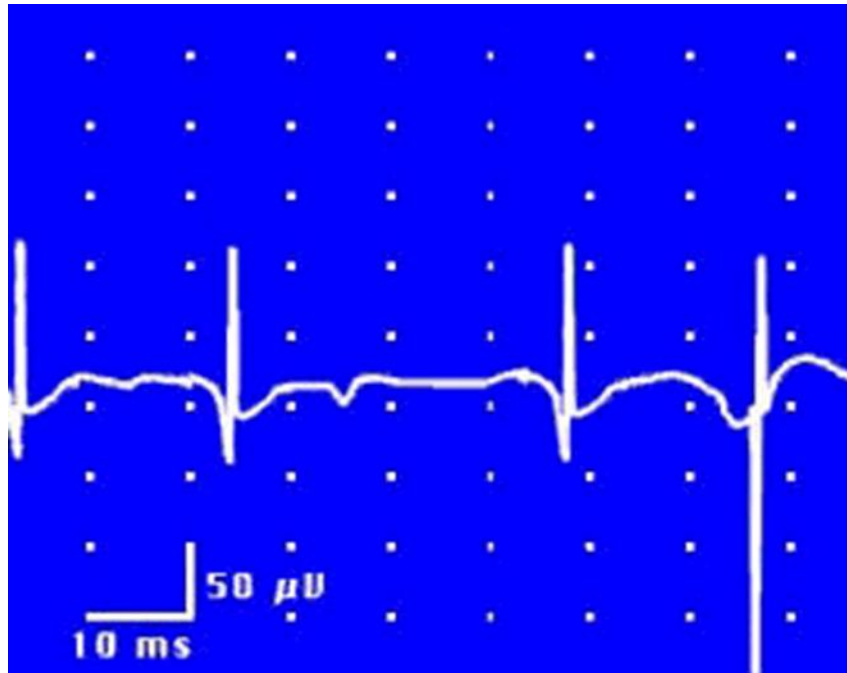

Cont...

3- Fasciculation potentials:

- These are high voltage, polyphasic, long duration potentials appear spontaneously associated with visible contraction of the muscle.
- May be benign and they occur in motor neuron disease, radiculopathy and neuropathy

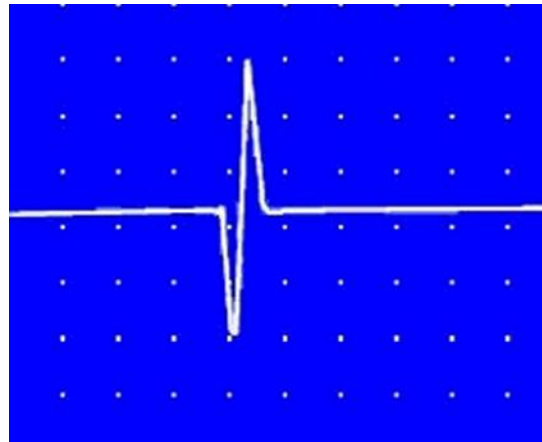

Neuropathic EMG changes

Denervated Muscle

Surviving motor unit A has taken over two of the fibres supplied by the dying fibre B

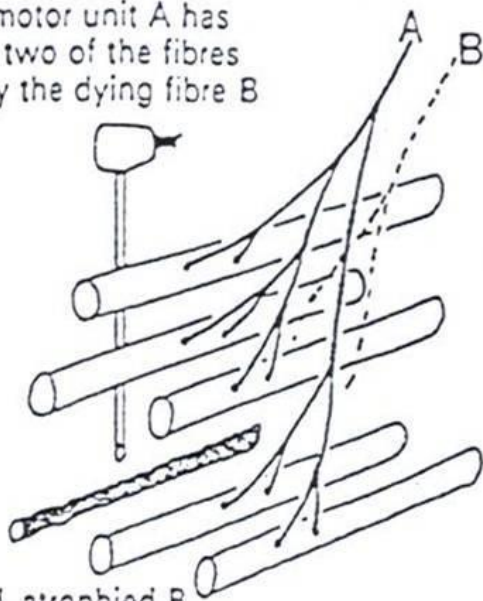

Denervated, atrophied B fibre, probably responsible for fibrillation

Figure 16.1A. Chronic Partial Denervation

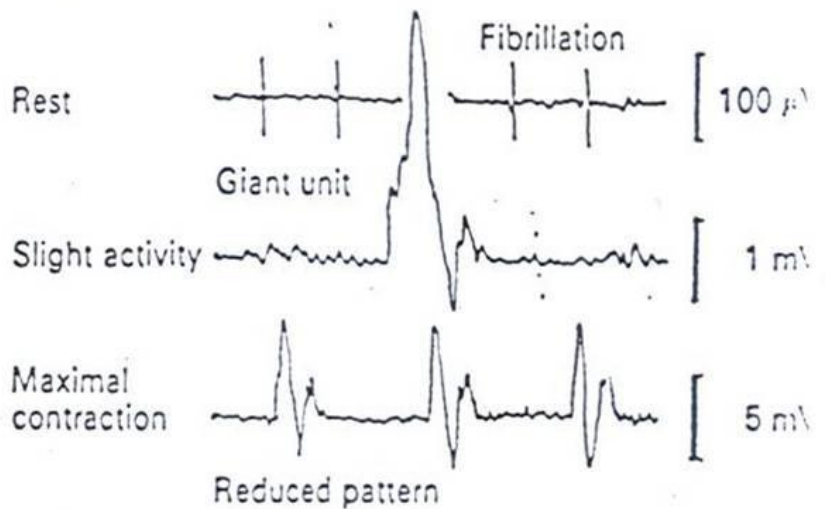

NEUROPATHY

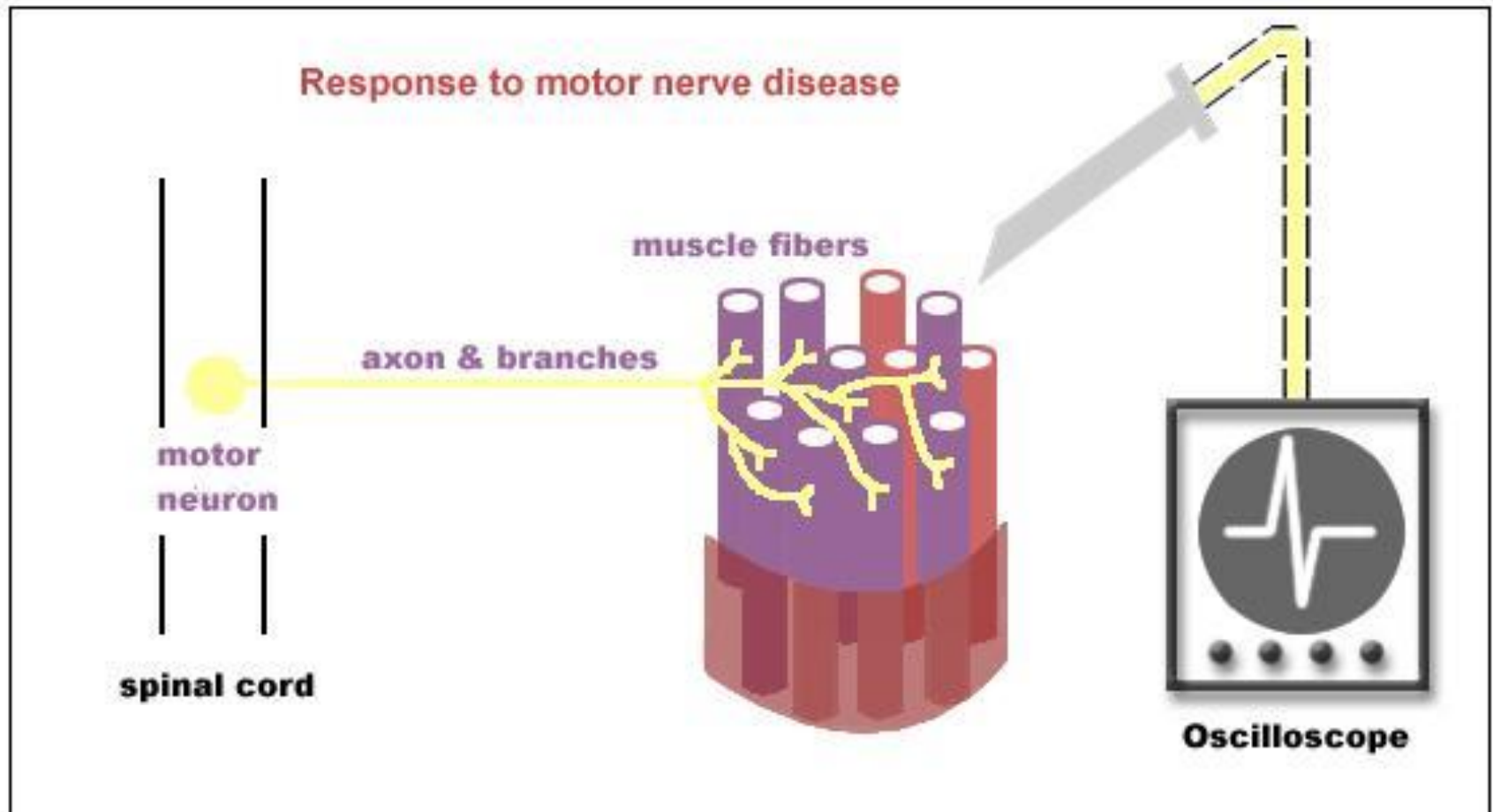

Myopathic EMG changes

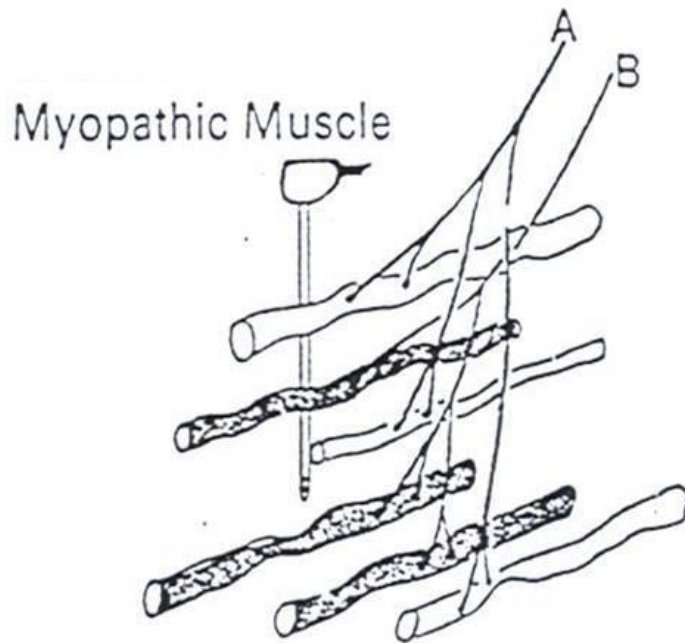

Muscle fibres supplied by both A and B are indiscriminately affected, although both nerve fibres are normal

Figure 16.1B. Myopathic E.M.G.

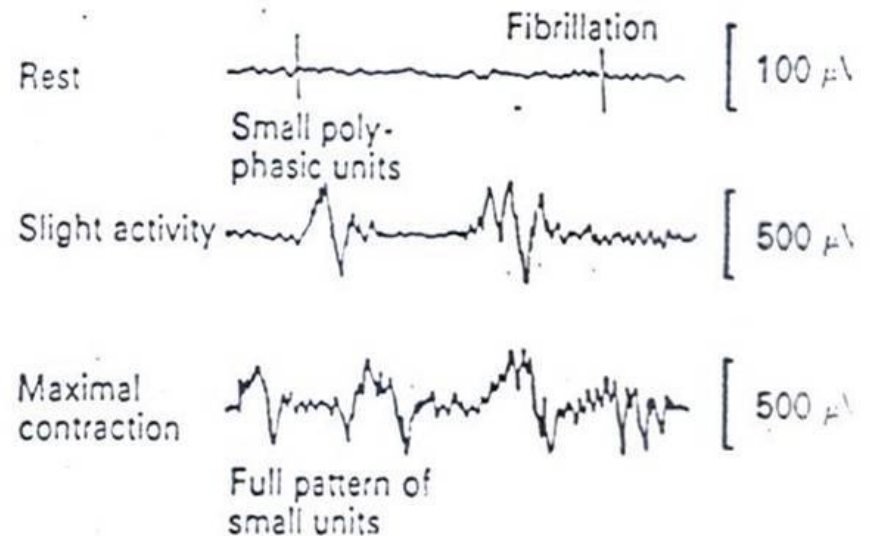

MYOPATHY

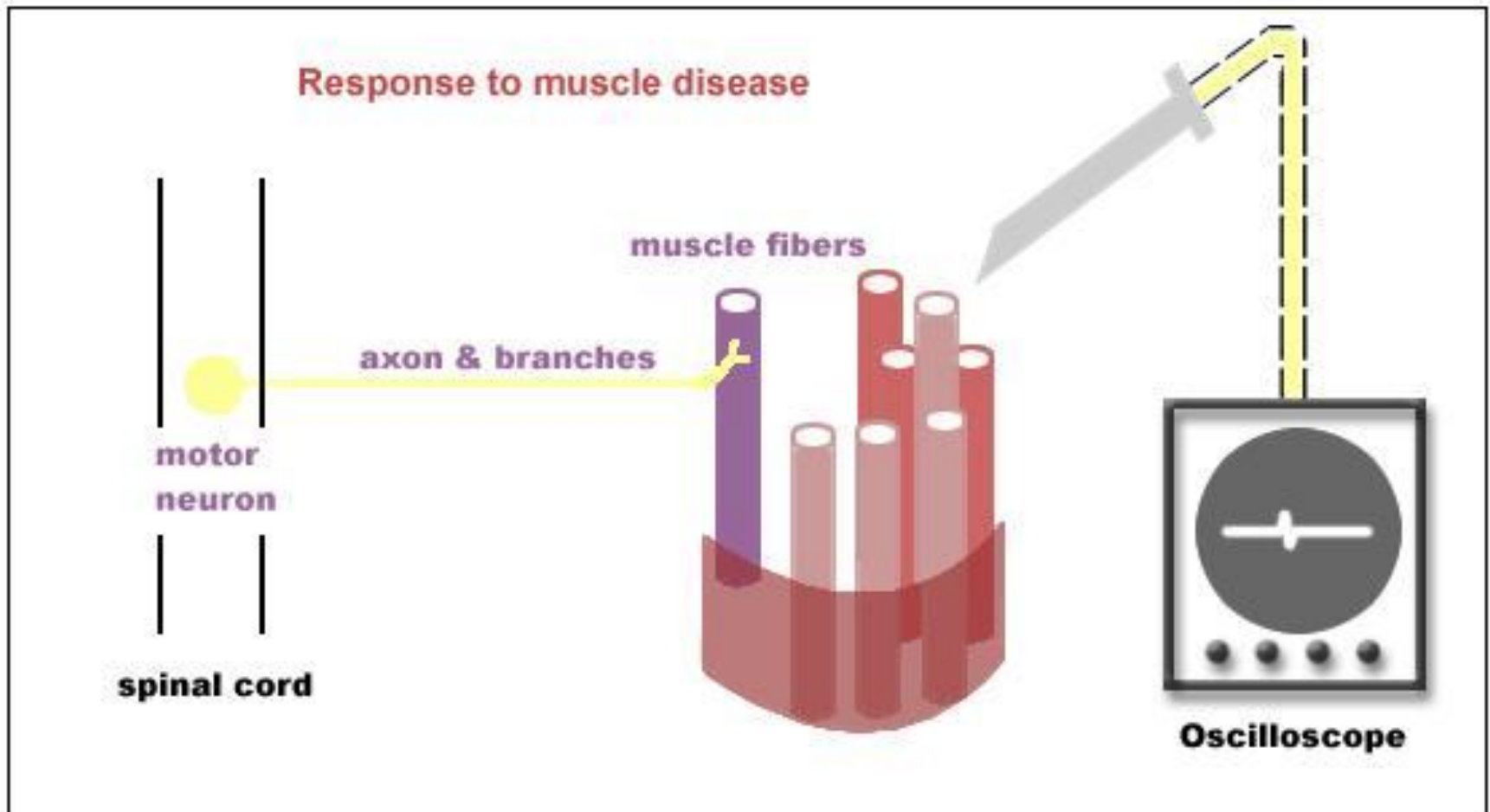

Analysis of a motor unit potential (MUP)

MUP	NORMAL	NEUROGENIC	MYOPATHIC
Duration msec.	3 - 15 msec	longer	Shorter
Amplitude	300 - 5000 μV	Larger	Smaller
Phases	Biphasic / triphasic	Polyphasic	polyphasic
Resting Activity	Absent	Present	Present
Interference pattern	full	partial	Full

Typical MUAP characteristics in myopathic, neuropathic & normal muscle

MUP	Myopathy	Normal	Neuropathy
Duration	< 3 msec	3 – 15 msec	> 15 msec
Amplitude	< 300 μ V	300-5000 μ V	> 5 mV
configuration	polyphasic	triphasic	Polyphasic

Normal Muscle

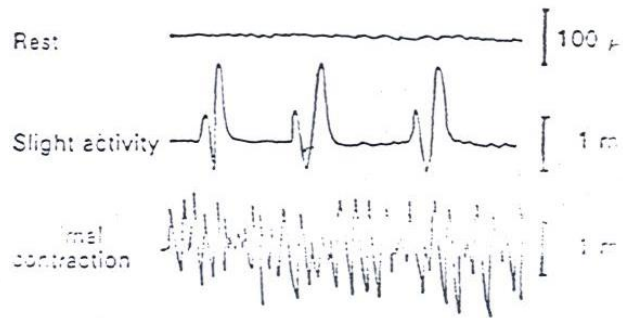
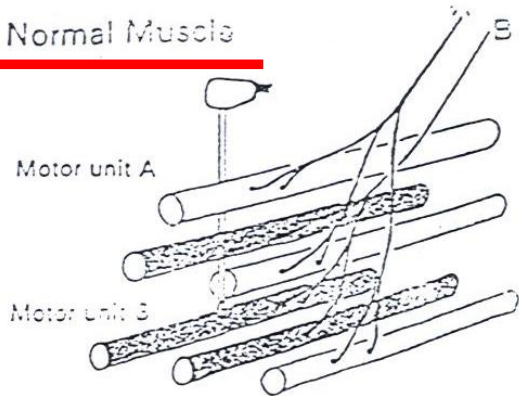

Denervated Muscle

Surviving motor unit A has taken over two of the fibres supplied by the dying fibre B

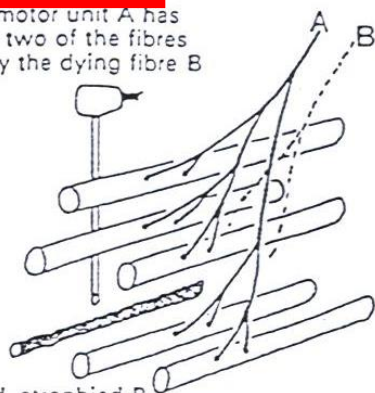

Denervated, atrophied B fibre, probably responsible for fibrillation

Myopathic Muscle

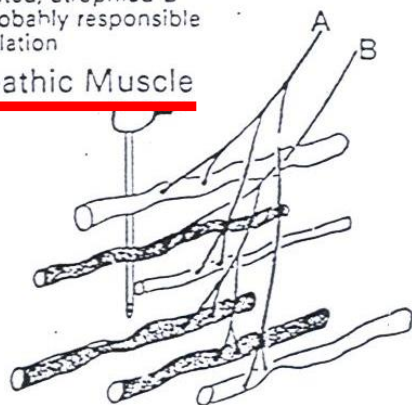

Muscle fibres supplied by both A and B are indiscriminately affected, although both nerve fibres are normal

Figure 16.1A. Chronic Partial Denervation

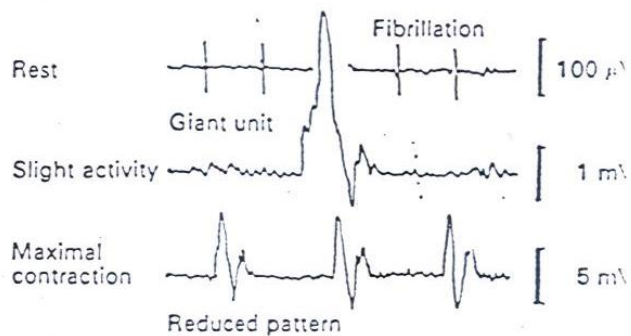
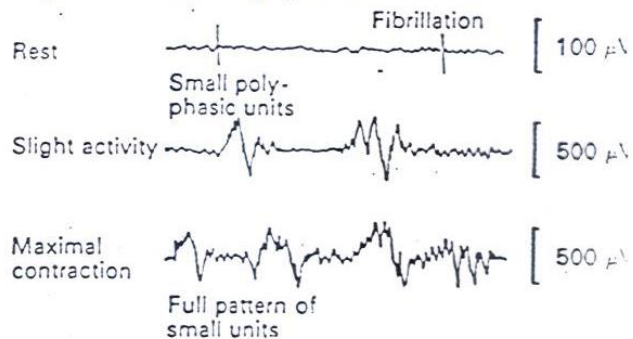

Figure 16.1B. Myopathic E.M.G.



THANK YOU