

بِسْمِ اللَّهِ الرَّحْمَنِ الرَّحِيمِ





بِسْمِ اللَّهِ الرَّحْمَنِ الرَّحِيمِ

”قالوا سبحانك لا علم لنا إلا ما

علمتنا إنك أنت العليم الحكيم“

صدق الله العظيم



BLOOD



2 - Composition and Functions of the Blood



Objectives;

Intended learning outcomes (ILOs)

After reviewing the PowerPoint presentation and the associated learning resources, the student should be able to:

- Describe the physical characteristics & composition of blood
- List the common functions of blood.
- Describe the composition of the plasma.
- Enumerate the plasma proteins and mention its functions
- Define the process of erythropoiesis, Discuss its sites and stages.
- Summarize the functions of red blood cells.
- Enumerate the factors affecting erythropoiesis.
- Describe the normal structure of Hemoglobin.

These slides are meant to be an aid and an adjunct to your textbook **NOT** its replacement

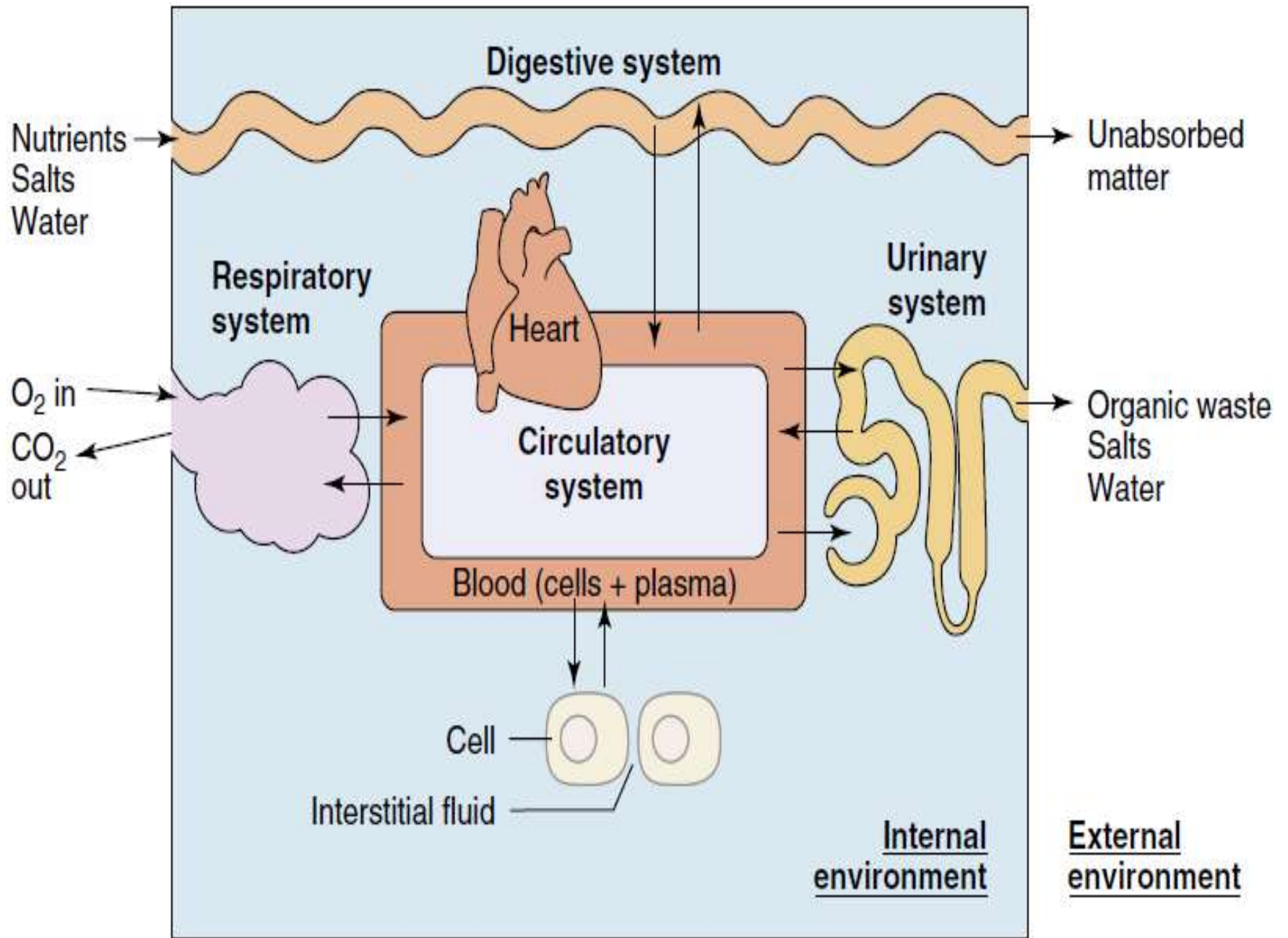

Major Components of the Circulatory System

- Heart
- Blood vessels
- Blood

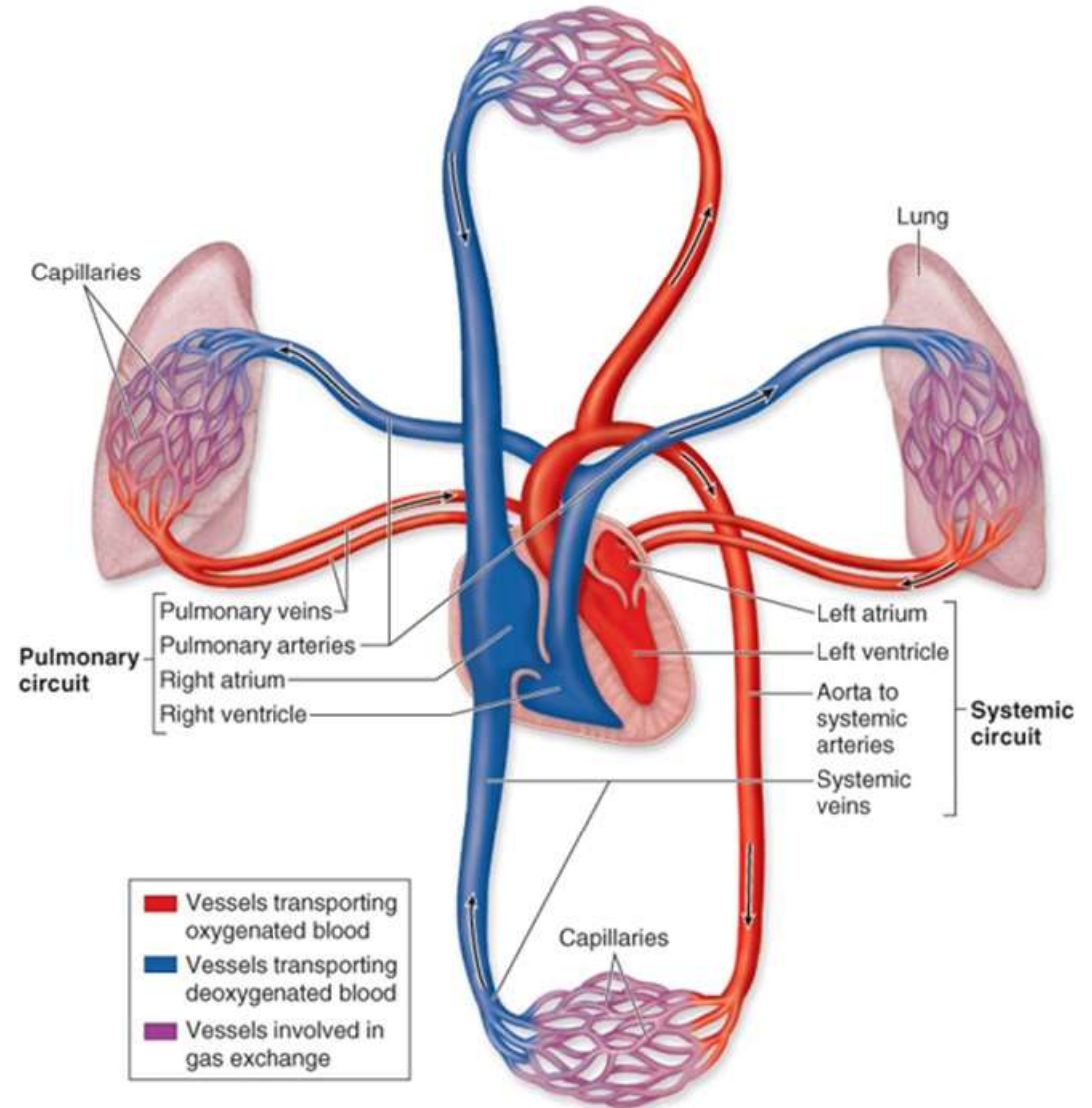

Composition of Blood

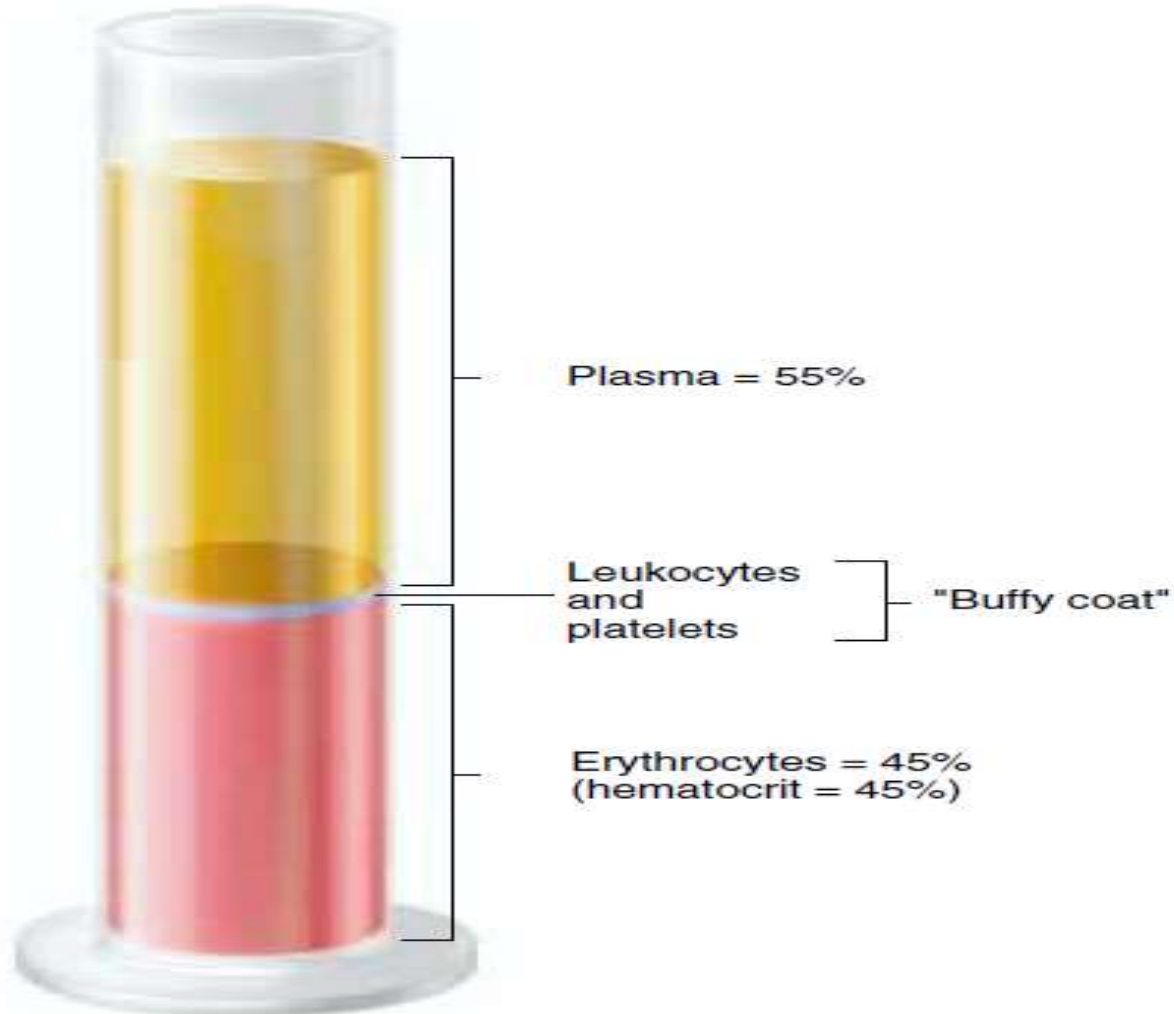

BLOOD CONSTITUENTS

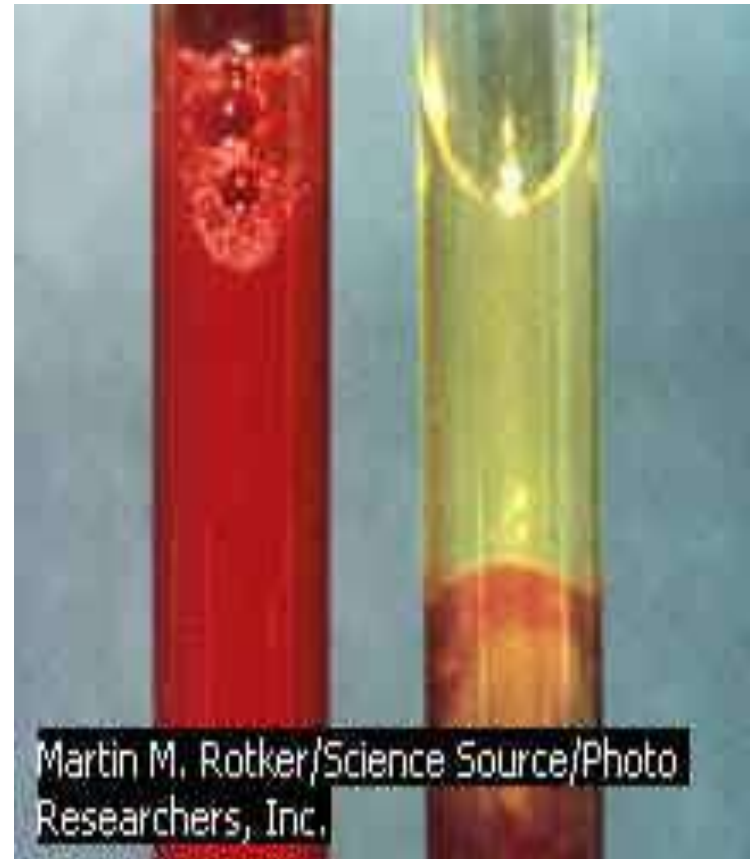
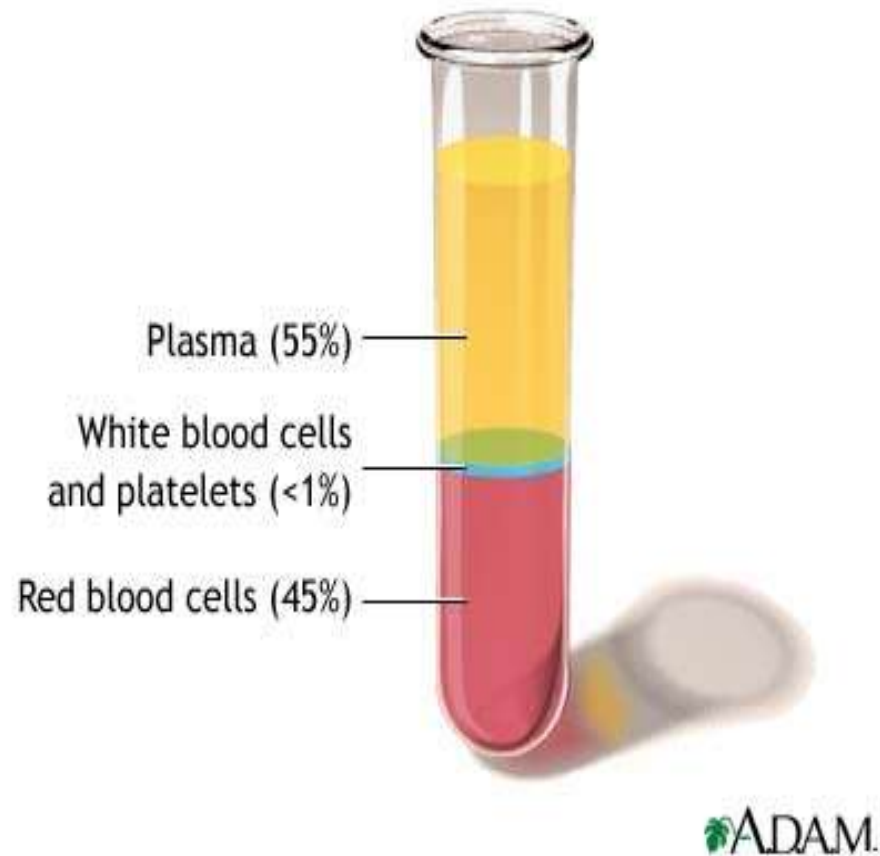

Some Physical Characteristics of Blood

□ Blood volume

- Blood makes up 7-9% of body weight
- Blood volume is 5 to 6 liters in adult males
4 to 5 liters in adult females

□ Viscosity (thickness and stickiness of blood)

- Blood is thicker (more viscous) than water and flows more slowly than water
- Plasma at 37°C is about 1.8-times more viscous than water; therefore, the relative viscosity of plasma (compared to water) is about 1.8
- Whole blood viscosity (relative to water) = 4.5-5.5

□ pH

- Slightly alkaline: 7.4 (= Neutral body pH)
- Ranges from 7.35 to 7.45

□ Color

- Bright red = O₂ rich
- Dull red = O₂ poor

□ Osmolarity

- Plasma osmolarity is about **300 mOsmol/L**
- Plasma osmolarity is equal to the osmolarity of Normal Saline = **0.9% NaCl Solution**. Hence, Normal Saline is an Isotonic solution

□ Osmotic Pressure

- Osmotic pressure is the pressure necessary to prevent net movement of water (in osmosis)
- In other words, osmotic pressure is the pressure developed by solutes dissolved in water working across a selectively permeable membrane.
- At normal plasma osmolarity of about 300 mOsmol/L, the total plasma osmotic pressure is about 5540 mmHg.

Some Physical Characteristics of Blood

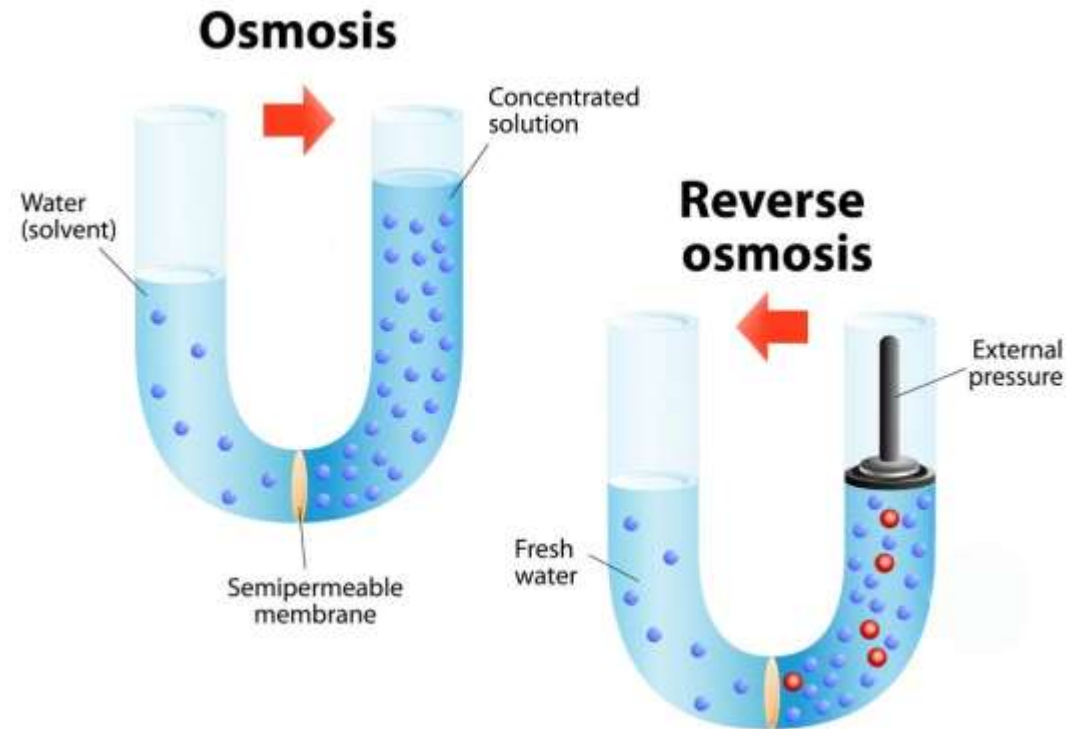

Functions of Blood

■ Blood transports = Transport

- Oxygen from the lungs and nutrients from the digestive tract
- Metabolic wastes from cells to the lungs and kidneys for elimination
- Hormones from endocrine glands to target organs

■ Blood maintains = Homeostasis

- Appropriate body temperature by absorbing and distributing heat
- Normal pH in body tissues using buffer systems
- Adequate fluid volume in the circulatory system

■ Blood prevents blood loss by = Haemostasis

- Activating plasma proteins and platelets
- Initiating clot formation when a vessel is broken

■ Blood prevents infection by = Immunity

- Synthesizing and utilizing antibodies
- Activating WBCs to defend the body against foreign invaders

Composition of Blood

• Cells and cell fragments =
“formed elements”: 45%

Erythrocytes = RBCs

Leukocytes = WBCs

Thrombocytes = platelets
(cell fragments)

• Matrix (plasma): makes up
55% of blood volume

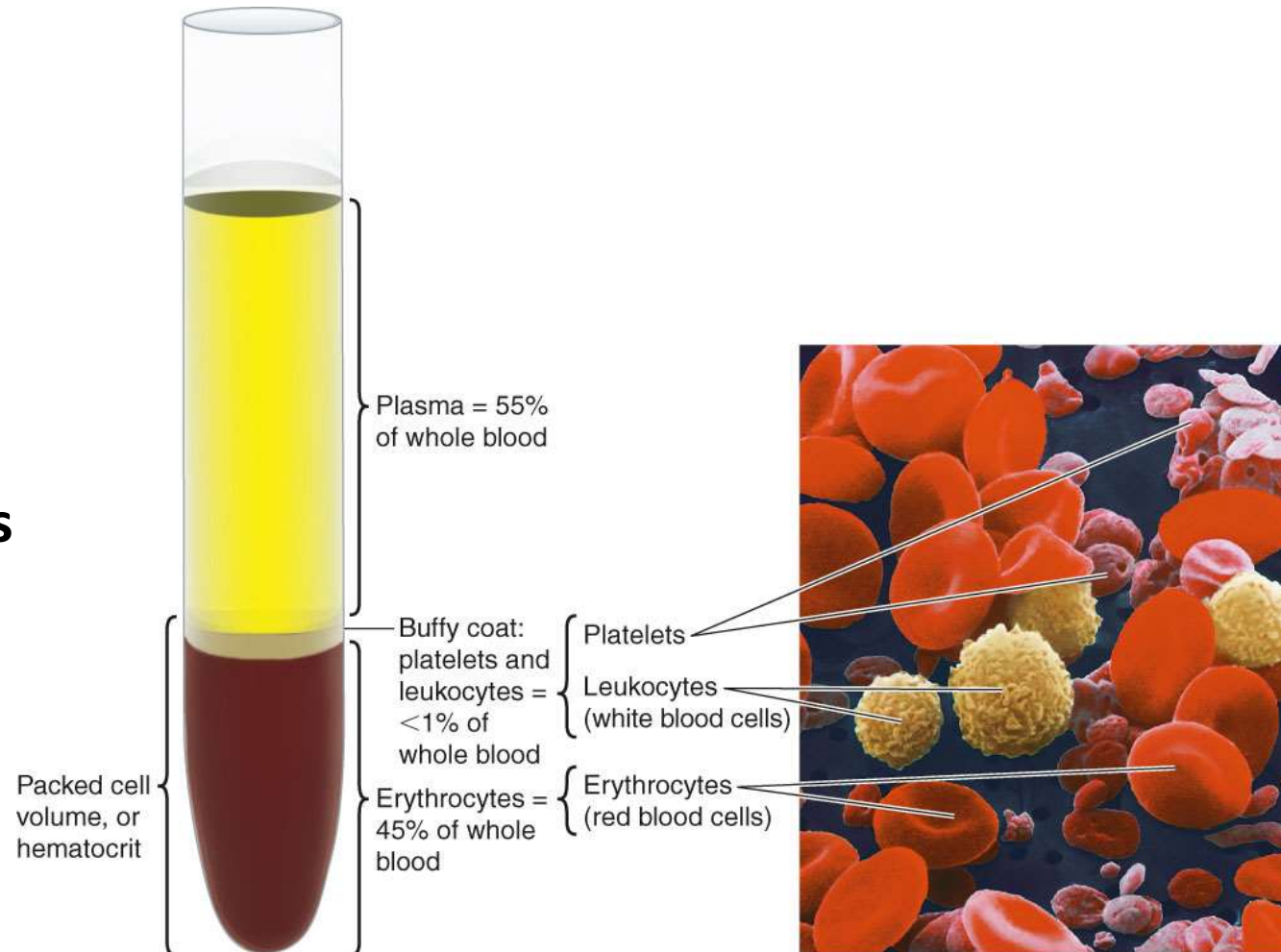

Composition of Blood

- 45% cells (formed elements)

- 99% RBCs
- < 1% WBCs and platelets

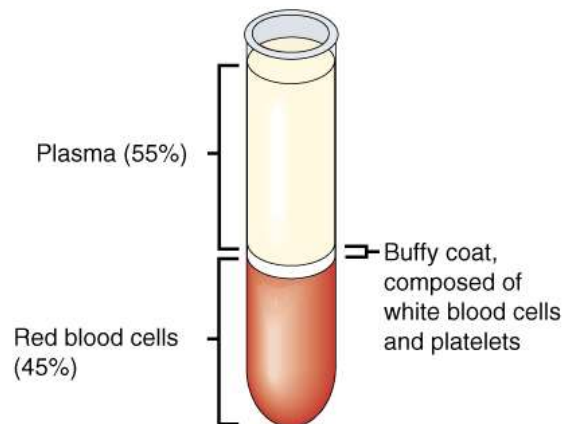
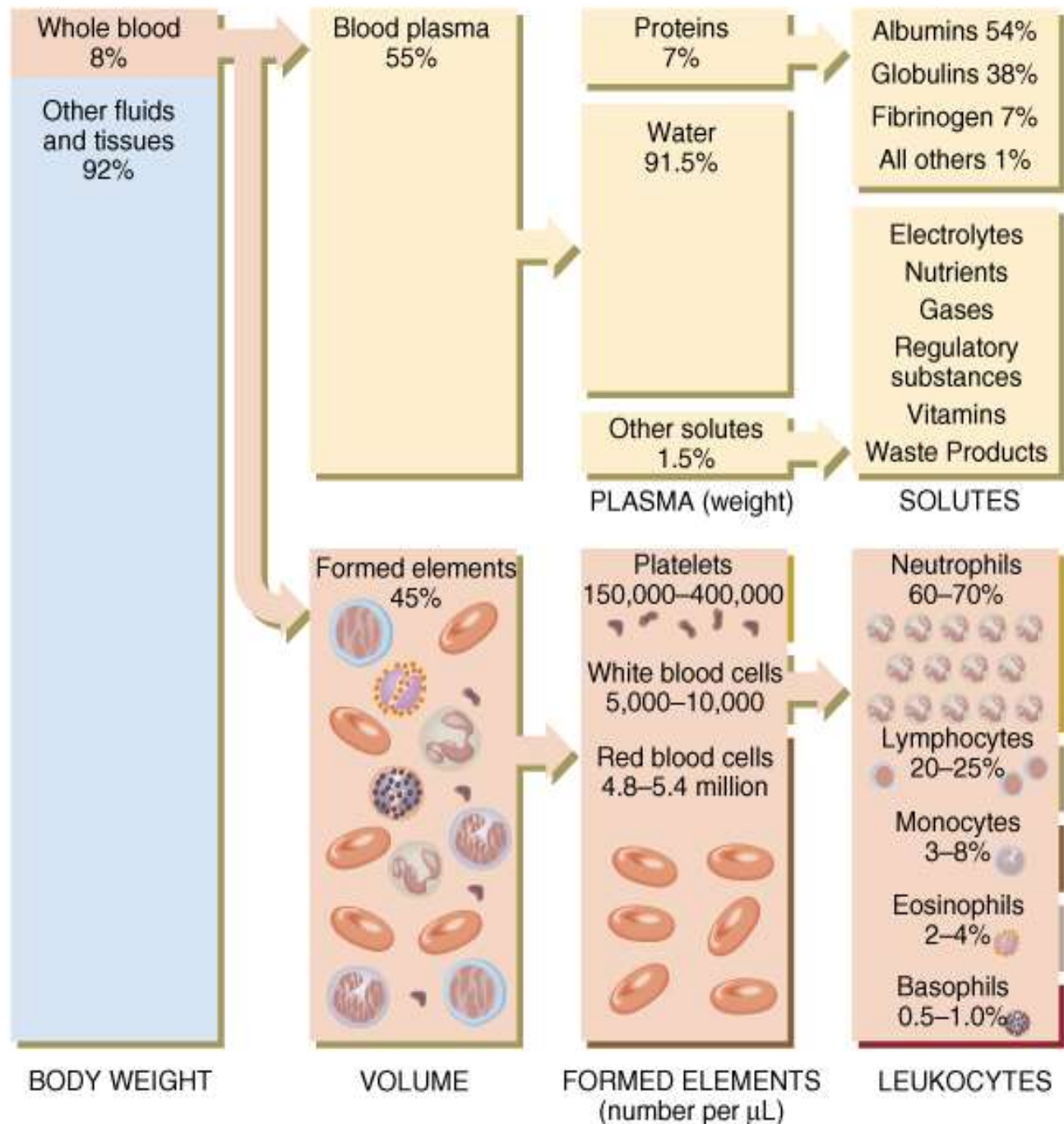

Plasma: Definition and Composition

❑ **Plasma = whole blood minus cells**

❑ **Constituents of plasma**

- **91.5% water**

- **7% plasma proteins**

- **1.5% other solutes including:**

- **Electrolytes**
- **Organic nutrients and wastes**
- **Respiratory gases**
- **Vitamins**

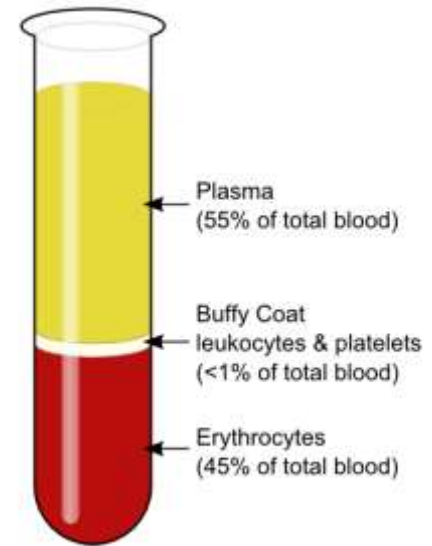

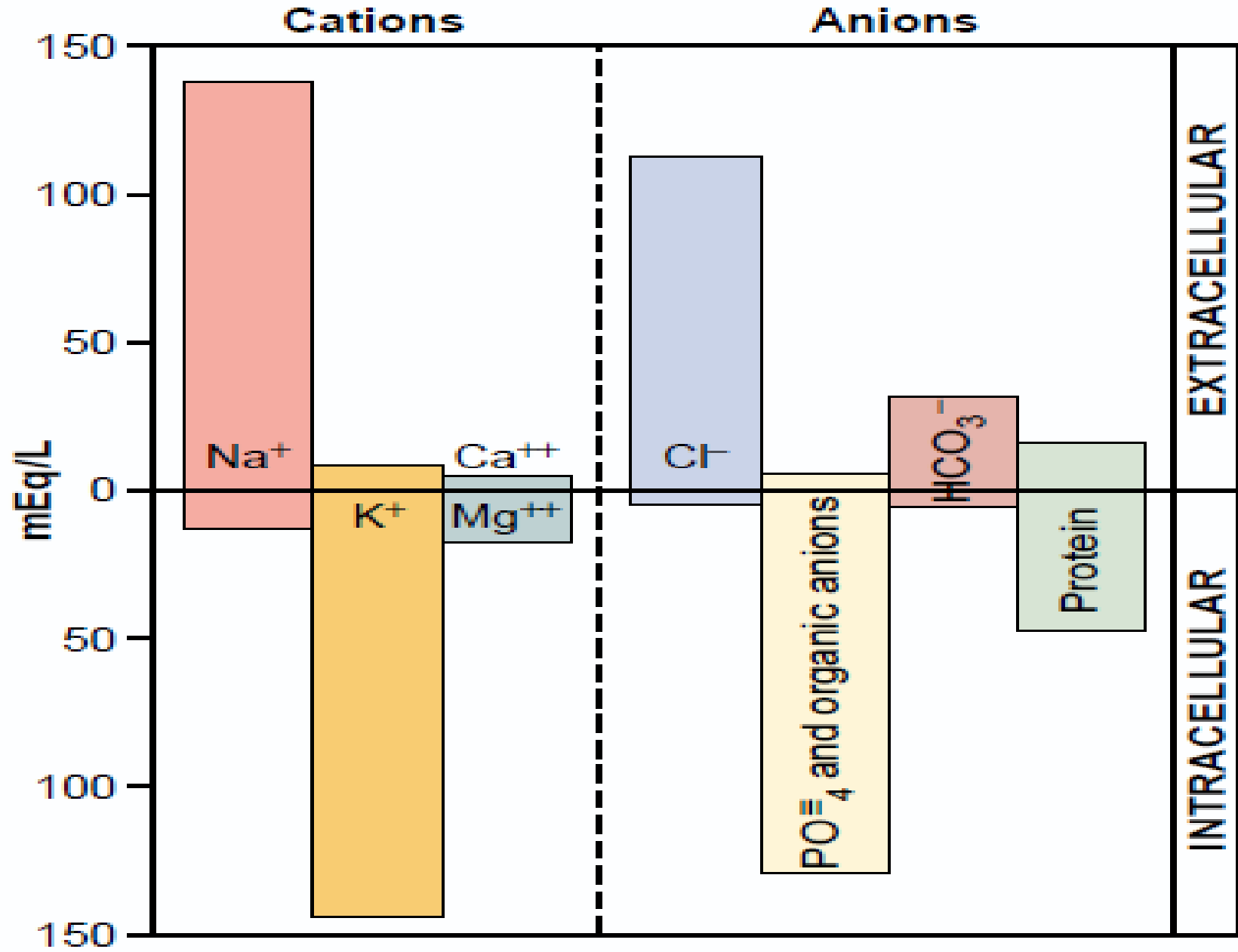

Functions of Plasma Proteins

- ❑ **Generation of plasma colloid osmotic pressure (oncotic pressure):** most capillary walls are relatively impermeable to the proteins in plasma, and the proteins therefore exert an osmotic force of about 25 mm Hg across the capillary wall (oncotic pressure that pulls water into the blood.) Albumin is the most abundant protein in plasma. **Albumin**
- ❑ **Buffering function of plasma proteins:** the plasma proteins are also responsible for 15% of the buffering capacity of the blood. **All types of plasma proteins**
- ❑ **Plasma proteins function as nonspecific carriers** for various hormones (e.g., cortisol, thyroxin), other solutes (e.g., iron, copper), and drugs. **Albumin + α Globulins**
- ❑ **Defense:** Gamma globulins are antibodies **γ Globulins**
- ❑ **Blood clotting (Fibrinogen and prothrombin).** **β Globulins, Fibrinogen & Prothrombin.**

Functions of Globulins

□ α Globulins.



Transport proteins

□ γ Globulins.



Defensive proteins =
Immunoglobulins =
Antibodies

□ β Globulins.



Coagulation factors

Plasma: Definition and Composition

- ❑ **Plasma** = whole blood minus cells
- ❑ **Serum** = plasma minus clotting proteins
 - If whole blood is allowed to clot
 - Then, clot is removed, the remaining fluid is **SERUM**
 - Thus, serum does not contain coagulation factors

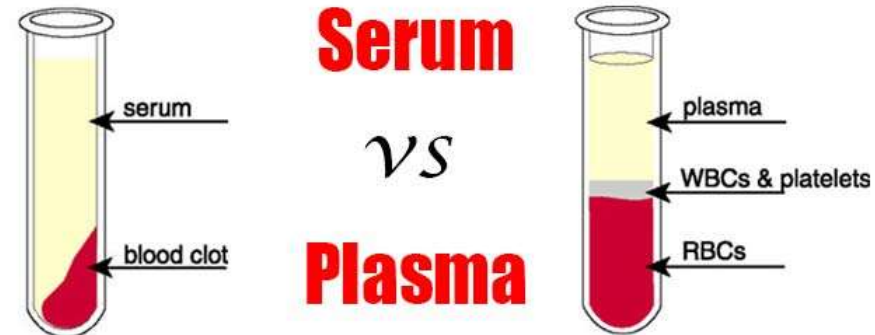
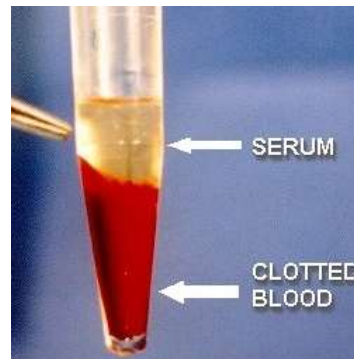
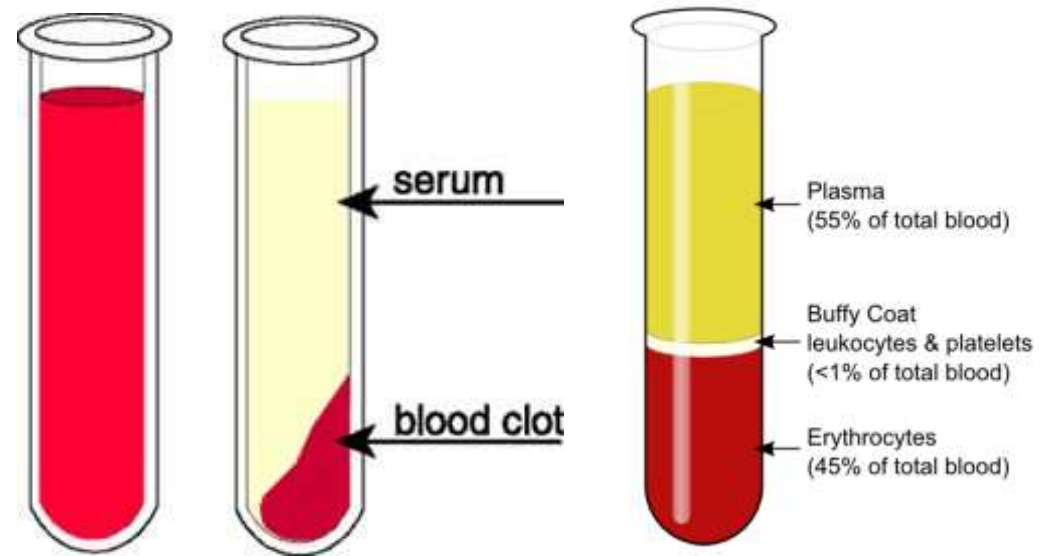

Serum = Plasma – Clotting Factors

Formed Elements of Blood

- Red blood cells (erythrocytes)
- Blood platelets (Thrombocytes)
- White blood cells (leukocytes)

granular leukocytes

neutrophils

eosinophils

basophils

agranular leukocytes

lymphocytes = T cells, and B cells

Monocytes (macrophages)



Blood Film (Blood Smear)

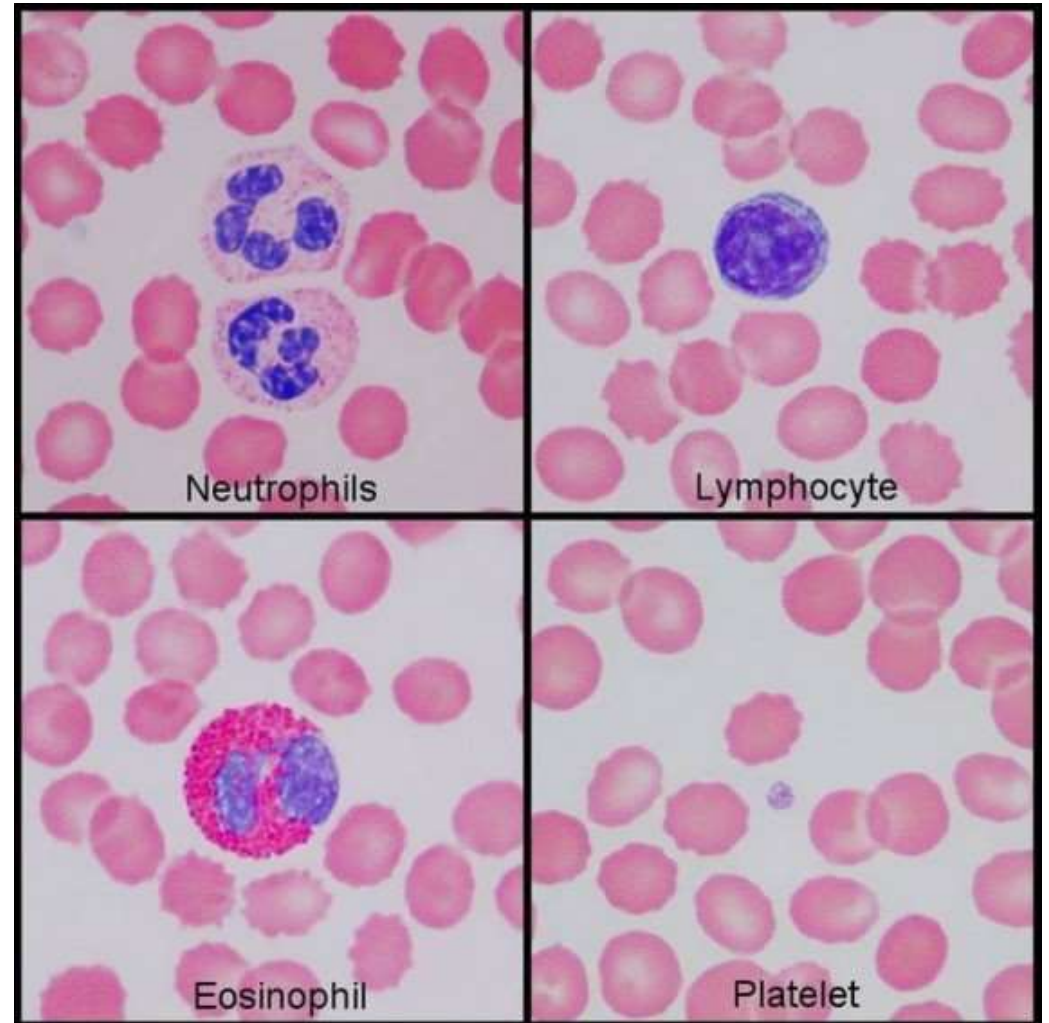
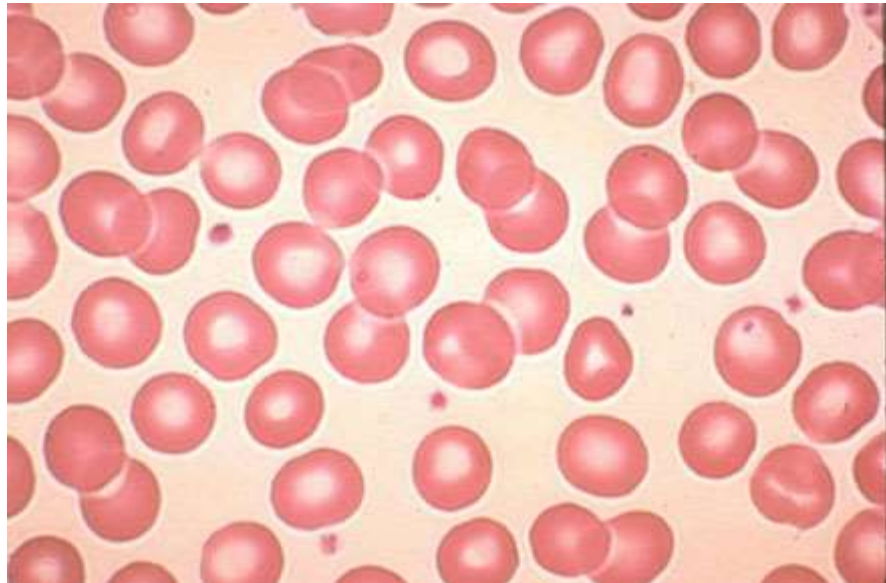

Blood Film (Blood Smear) Technique

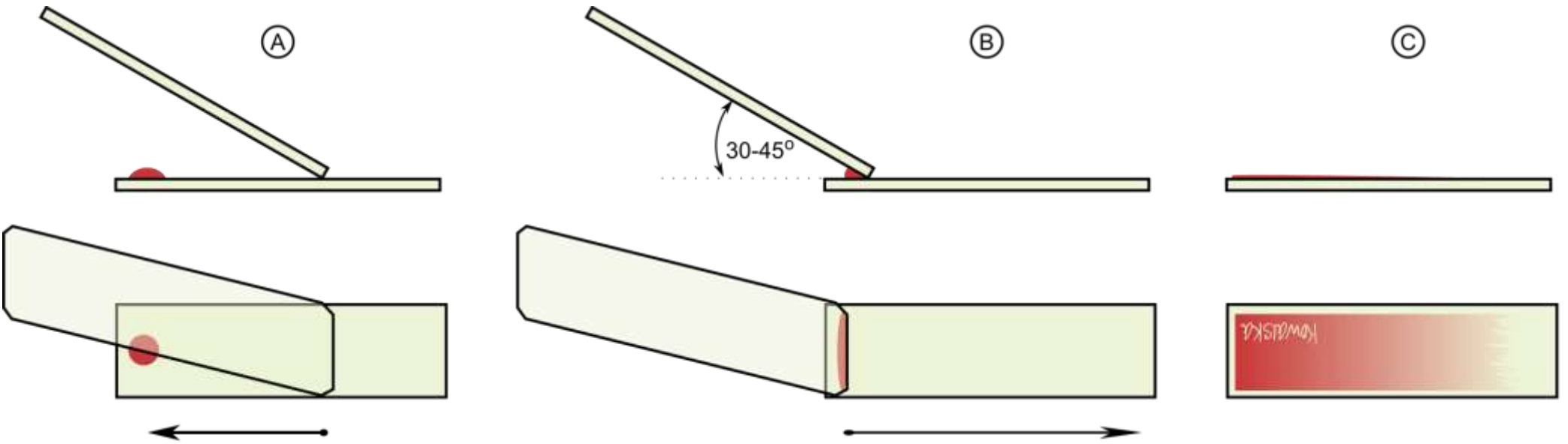

Formation of blood cells = Poiesis



RBCs = Erythrocytes



Erythropoiesis



WBCs = Leukocytes



Leukopoiesis



Platelets = Thrombocytes



Thrombopoiesis

Site: All occurs in the bone marrow

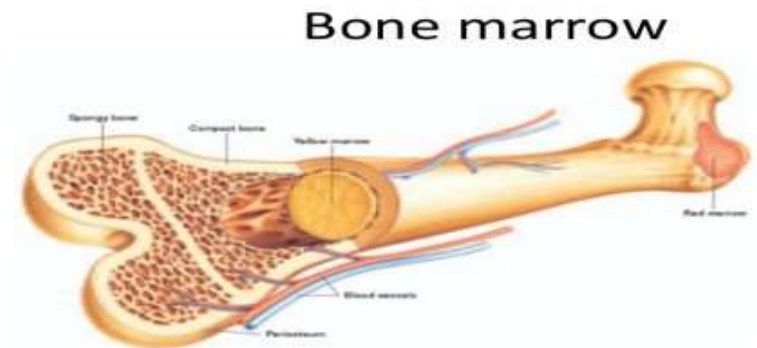



RBCs

Shape: Biconcave discs. Due to the presence of the protein Spectrin in the cell membrane. The membrane is elastic to allow passage into capillaries.

Diameter: 7.5 μ **Thickness:** 2 μ **Volume:** 90 – 95 μm^3

Contains: Haemoglobin: (For Gas transport).

Carbonic anhydrase enzyme (CA): For buffer function.

2 – 3 DPG enzyme: For anaerobic ?? glucose metabolism. Also controls the affinity for Oxygen binding.

Does not have: nucleus, mitochondria, ribosomes, endoplasmic reticulum or Golgi apparatus.

Functions:

1 – O₂ and CO₂ transport.

Haemoglobin binds O₂ in the lungs and releases it in the tissues (Reversible binding).

2 – Buffer function.

Haemoglobin had 85% of the buffering power of the blood.

Count (Red cell count = RCC):

In males 5,200,000 (\pm 300,000) / Cubic micron (μ^3).

In females 4,700,000 (\pm 300,000) / Cubic micron (μ^3).

If decreased = Anemia

If increased = Polycythemia

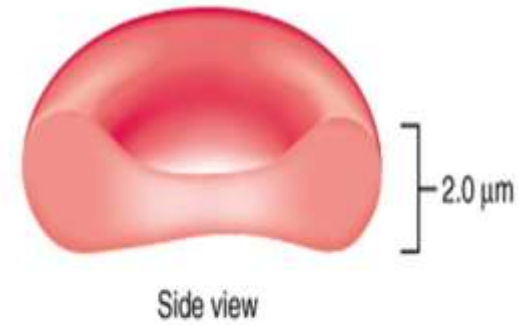

Side view

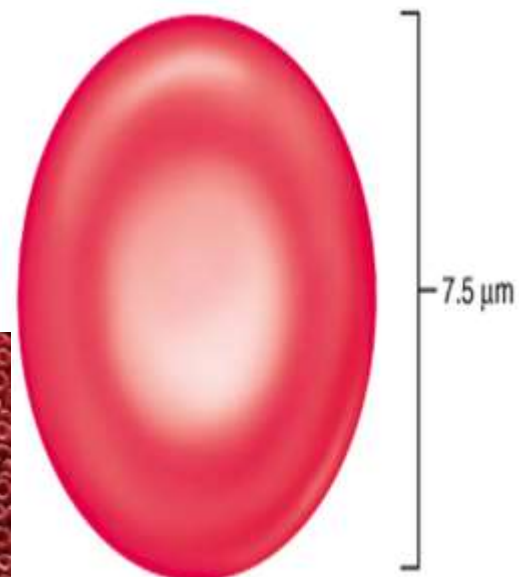

Top view



Hematocrit; Hct (PCV)

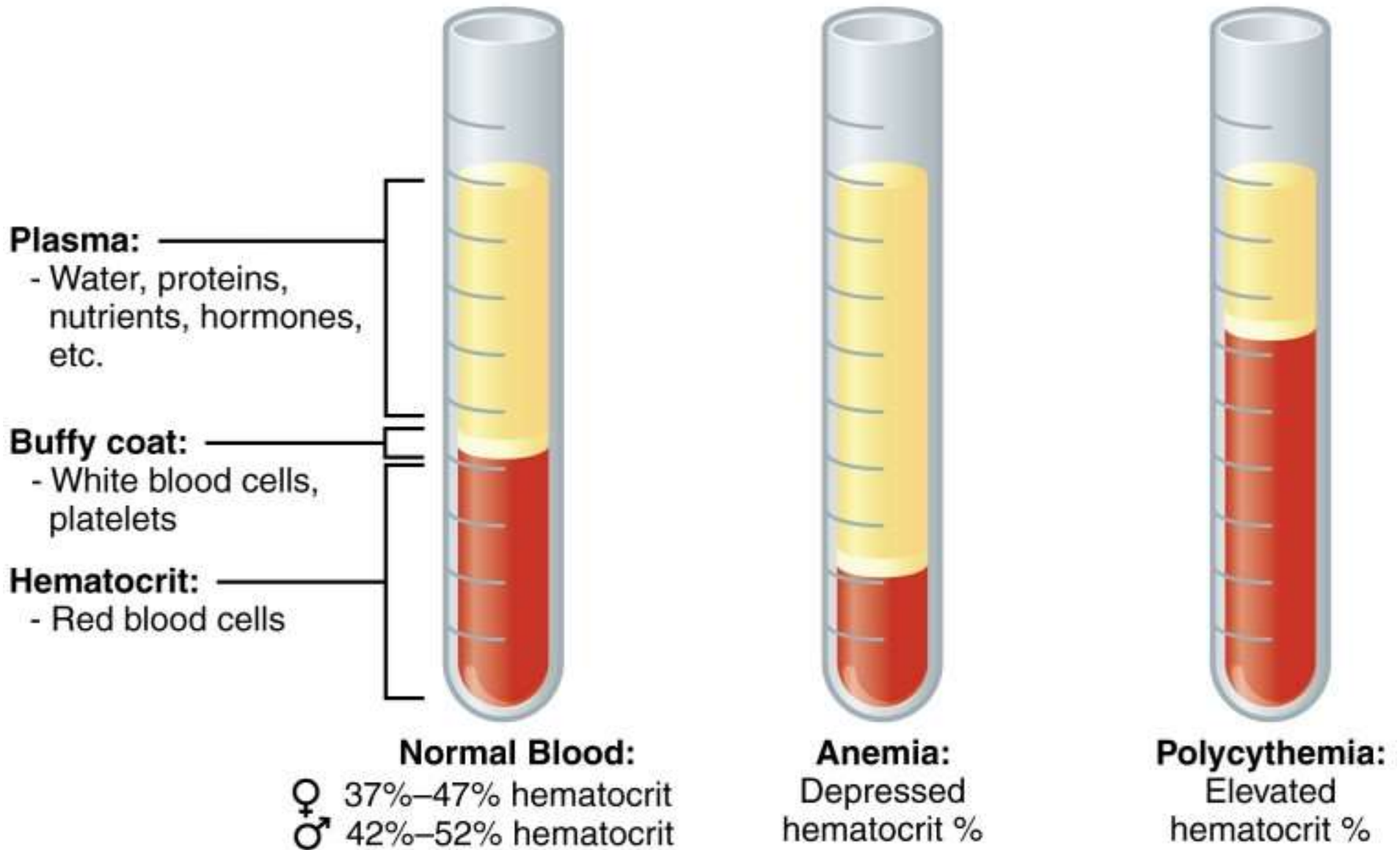

Clinical correlation

Hereditary Spherocytosis

Cause: Congenital deficiency of the protein spectrin.

Manifestation: Anemia + spherical RBCs instead of the normal biconcave shape.

On blood film: Loss of central pallor. Maybe polychromasia.

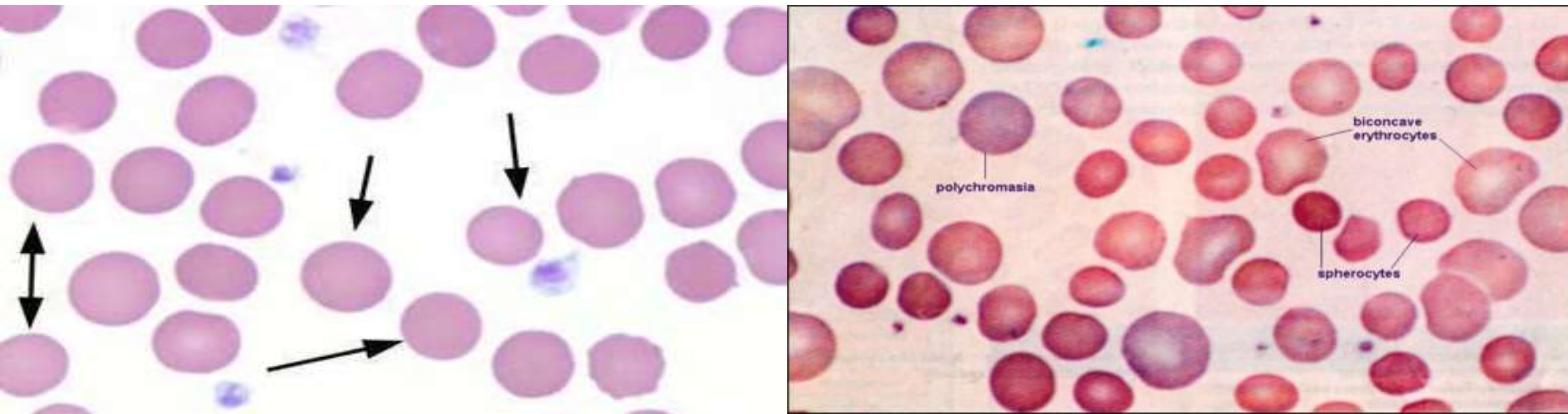

- Globular protein
- Heme + Globin

Hemoglobin (Hb)

Accounts for > 95% of protein in RBC

Main functions: transportation of respiratory gases. It carries ~ 98.5% of all O₂ ??

Hb Content of Blood

Concentration of Hb in the Blood

Measured as g/dl (grams per deciliter, or per 100 ml)

Average values:

Male: 13.5 – 17.5 g/dl (16 g/dl)

Female: 12.0 – 15.5 g/dl (14 g/dl)

Infants: 14.0 – 19.0 g/dl

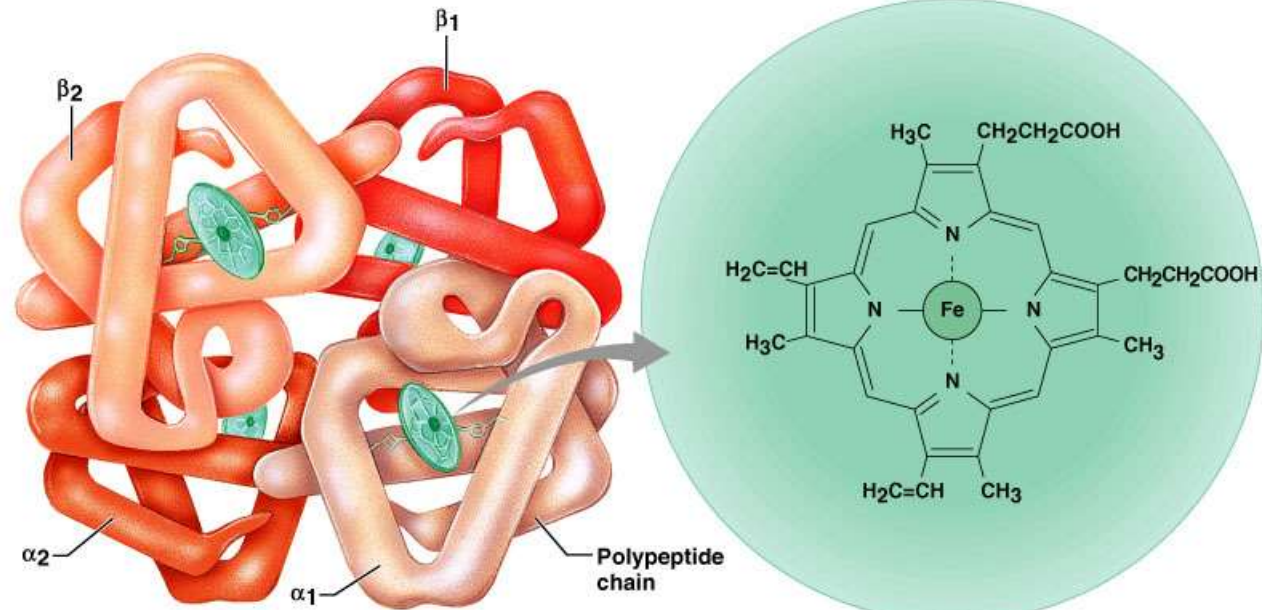

(a) Hemoglobin

(b) Iron-containing heme group

Copyright © 2004 Pearson Education, Inc., publishing as Benjamin Cummings.

- ❑ Each gram of pure hemoglobin is capable of combining with 1.34 ml of oxygen.
- ❑ Therefore, in a normal man a maximum of about 20 milliliters of oxygen can be carried in combination with hemoglobin in each 100 milliliters of blood, and in a normal woman 19 milliliters of oxygen can be carried.

Types of Hemoglobin

Hb – A = Adult hemoglobin (98%)

2 alpha + 2 beta chains.

Hb – F = Fetal hemoglobin (Hemoglobin of intrauterine life)

2 alpha + 2 gamma chains.

Hb – A2 (2%)

2 alpha + 2 delta chains.

Types of Hemoglobin

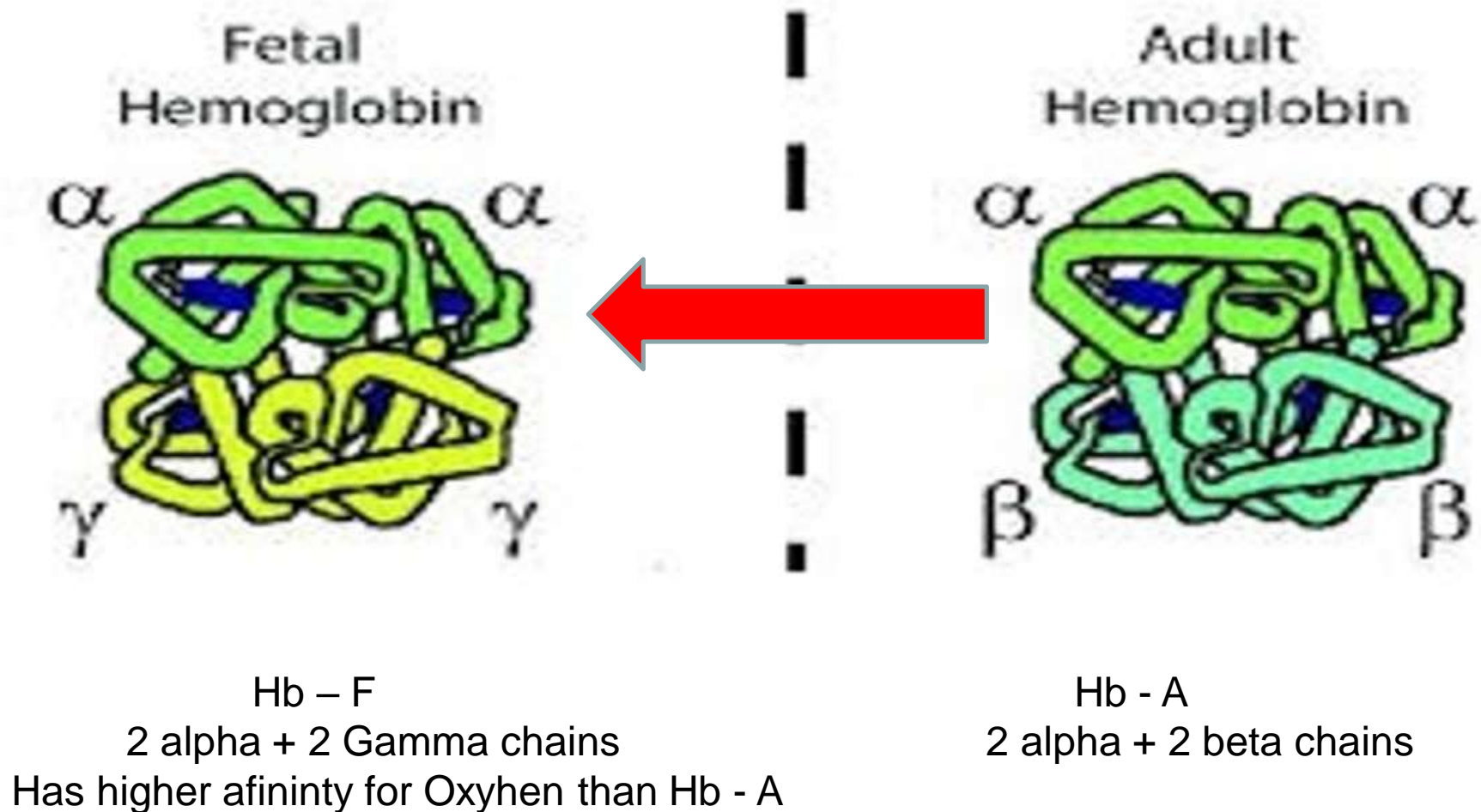

Abnormal types of Hemoglobin

Several types.

Examples:

Thalassemia: Decreased synthesis of the globin polypeptide chains.

Sickle cell anemia: Abnormal sequence of the amino acids in the globin polypeptide chains.



RBCs

Erythropoiesis

Definition

Sites

Stages

Factors

Definition: Formation of new RBCs.

Sites: Bone marrow.

During intrauterine life: Liver – Spleen – Lymph nodes.

Before the age of 20 years: Bone marrow of all bones.

After the age of 20 years: Bone marrow of membranous bones only.

RBCs Erythropoiesis Sites

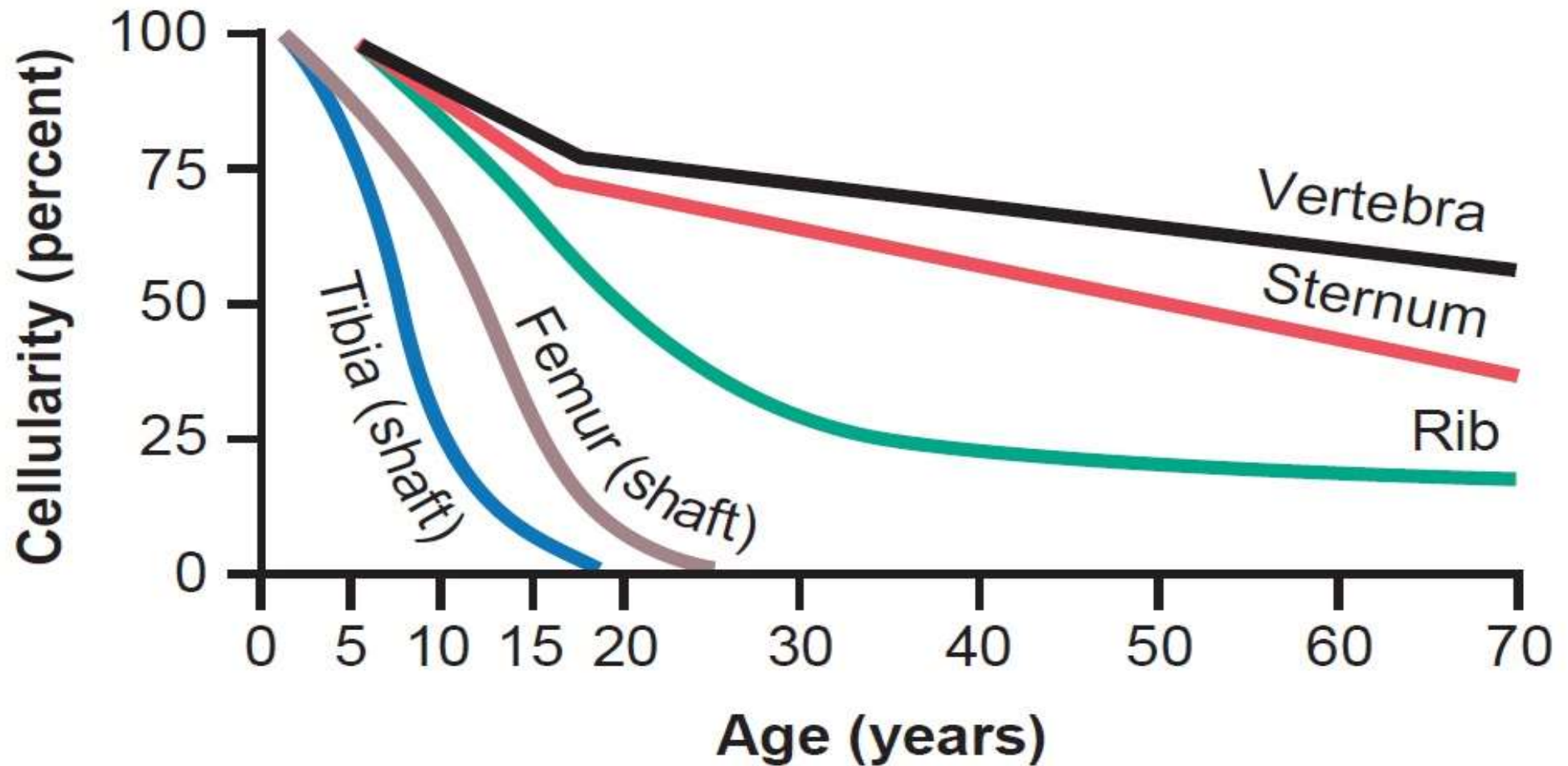

RBCs

Erythropoiesis

Stages

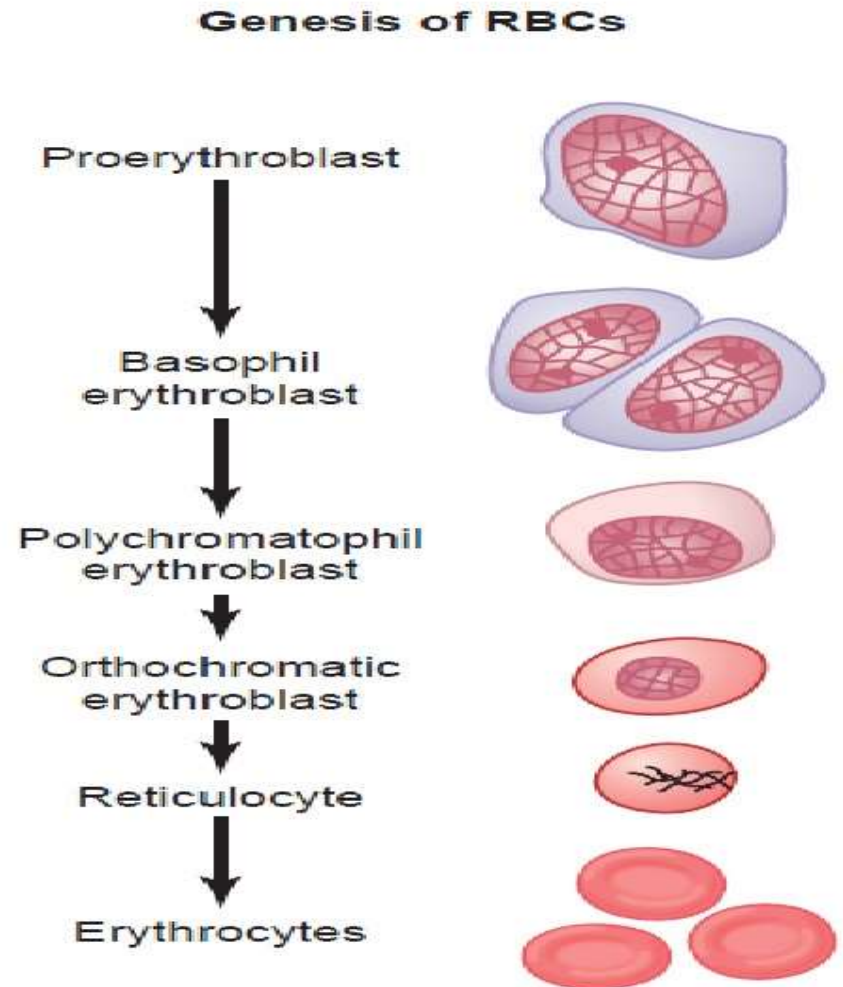
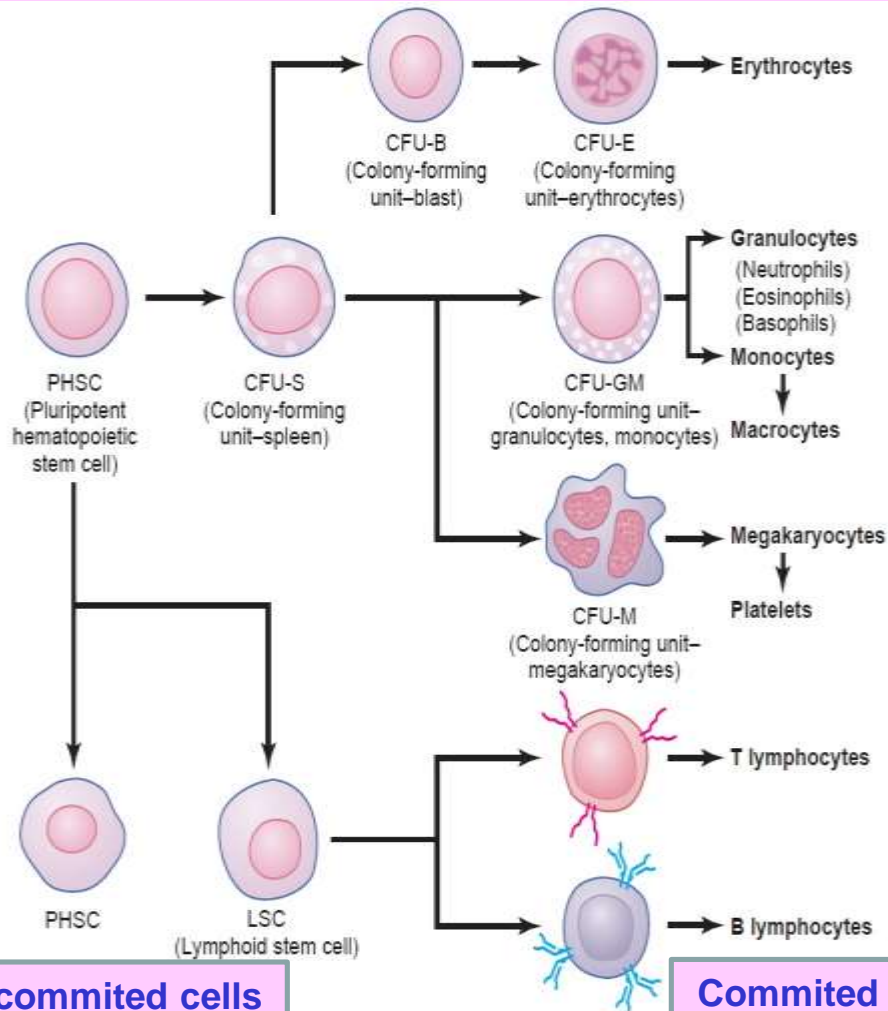

RBCs

Erythropoiesis

Factors

Oxygen supply to the tissues (Hypoxia).

Dietary requirements (Vitamins – Iron – Copper – Cobalt – Zinc – Other elements).

Healthy organs (Bone marrow – Liver – Kidney).

RBCs Erythropoiesis Factors Oxygen supply to the tissues (Hypoxia)

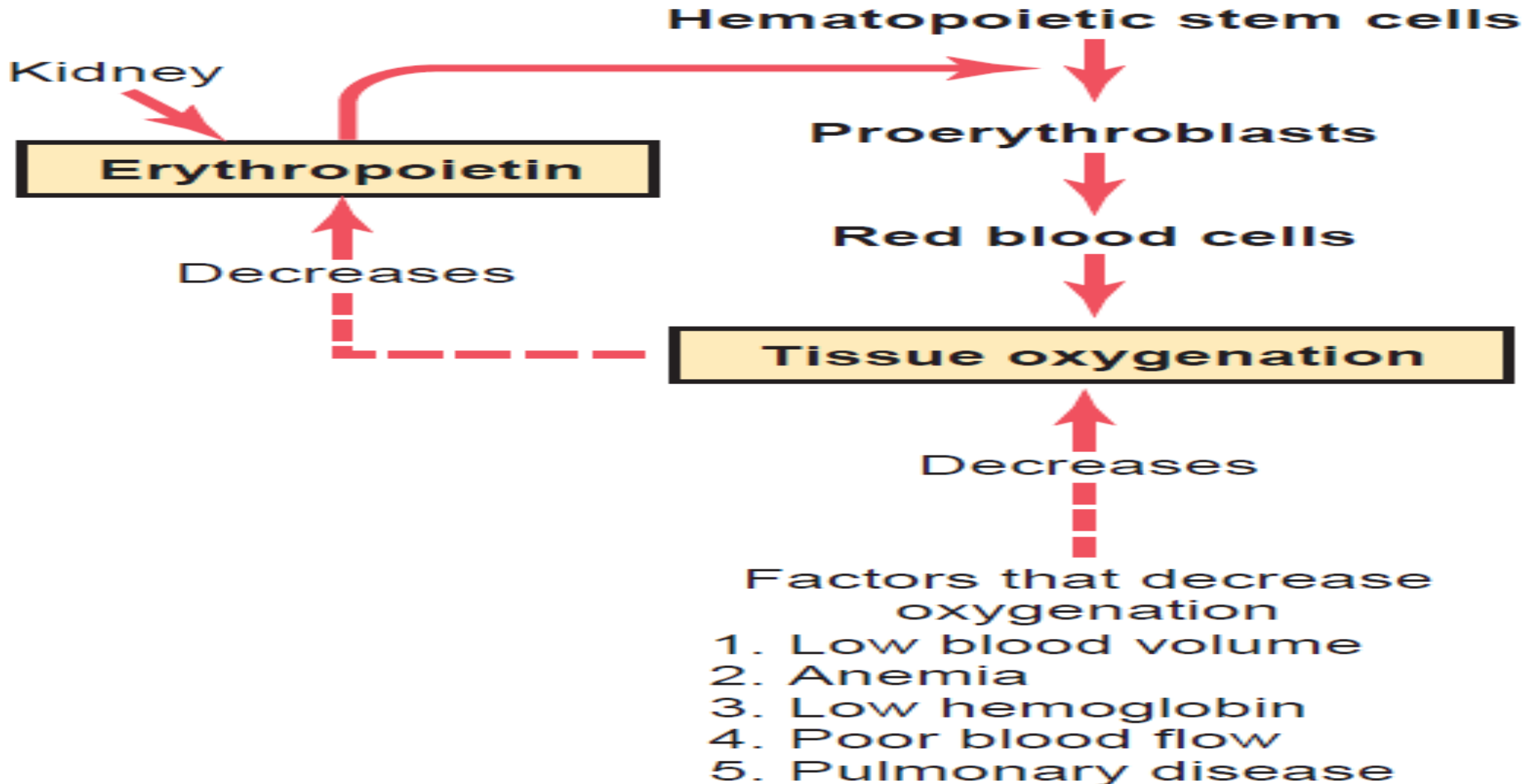

Thank You