

MECHANISMS FOR CONCENTRATING & DILUTING URINE

Regulation of ECF osmolarity

Objectives

At the end of this session, students should be able to;

- Identify and describe that the loop of Henle is referred to as countercurrent multiplier and the vasa recta as countercurrent exchanger systems in concentrating and diluting urine.
- Explain what happens to osmolarity of tubular fluid in the various segments of the loop of Henle when concentrated urine is being produced.
- Explain the factors that determine the ability of loop of Henle to make a concentrated medullary gradient.
- Differentiate between water diuresis and osmotic diuresis.
- Appreciate clinical correlates of diabetes mellitus and diabetes insipidus.

ECF Osmolarity

- Maintaining a constant concentration of solutes & electrolytes in the ECF is important for normal cellular function.
- The concentration of solutes in the ECF = **osmolarity**.
- Normal ECF osmolarity \approx **300 mOsm/L**
- **What determines the osmolarity of ECF?**

$$\text{Osmolarity} = \frac{\text{Amount of solute}}{\text{Volume of ECF}} \longrightarrow \boxed{\text{Water}}$$

Water Balance

Input = output

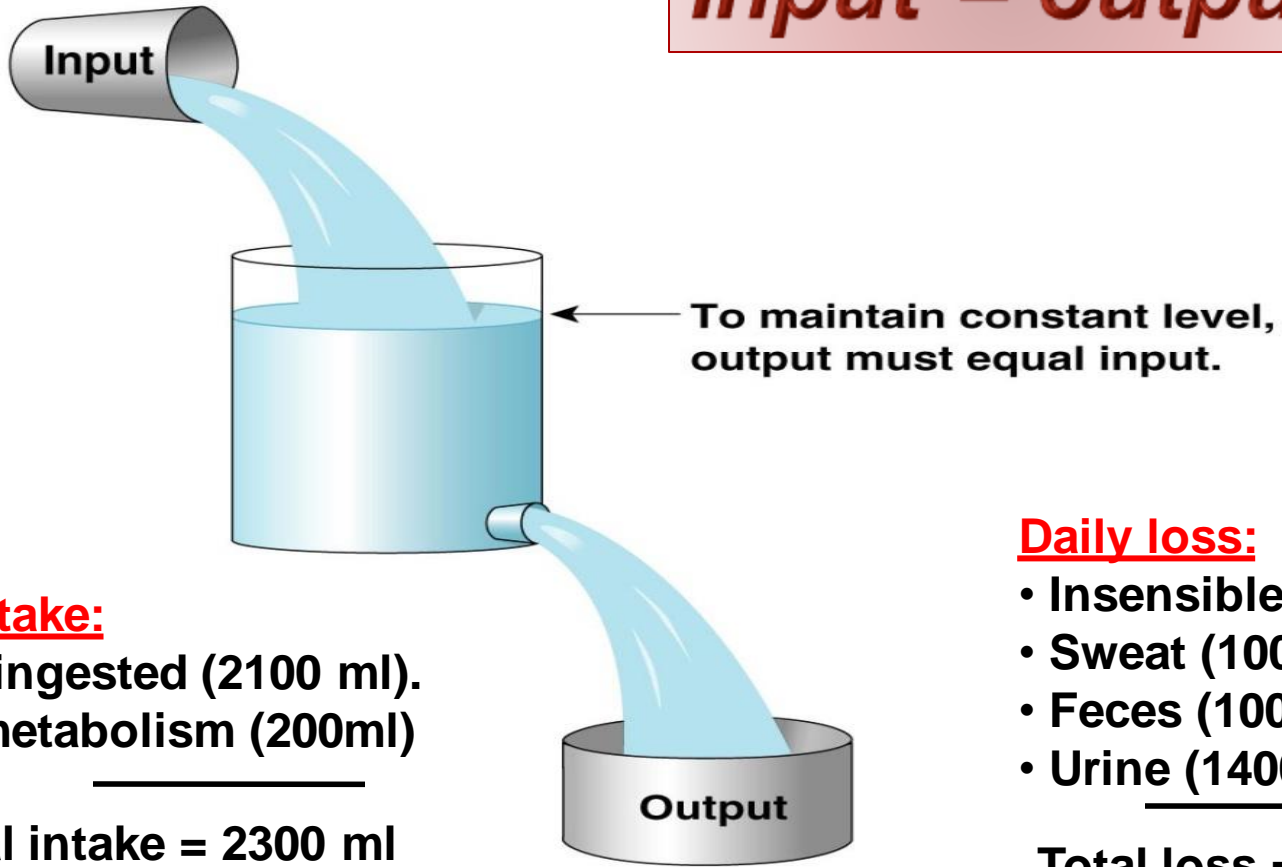

Water intake:

- Fluids ingested (2100 ml).
- From metabolism (200ml)

Total intake = 2300 ml

Daily loss:

- Insensible loss (700 ml)
- Sweat (100 ml).
- Feces (100 ml).
- Urine (1400 ml).

Total loss = 2300 ml

Copyright © 2007 Pearson Education, Inc., publishing as Benjamin Cummings.

Water Balance

Simplified version!

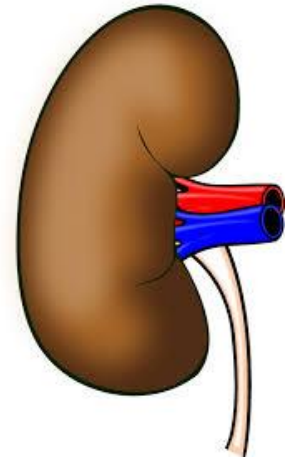
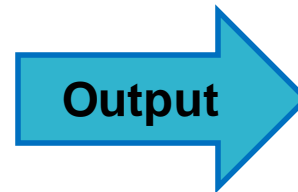
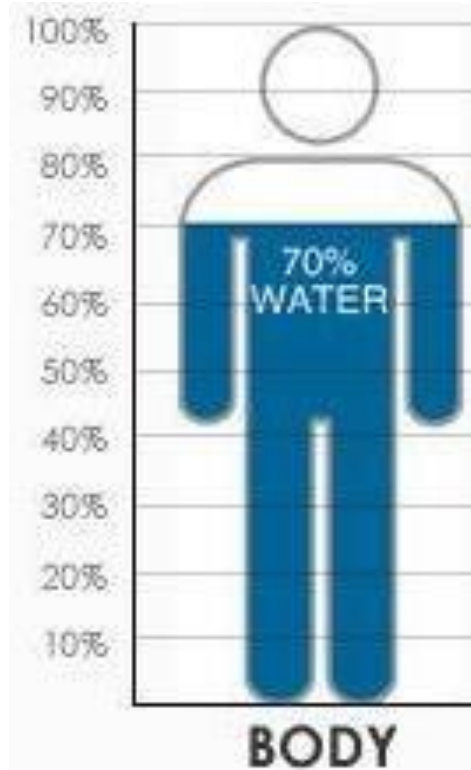
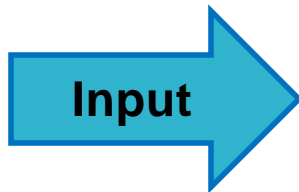

Urine

Regulation of H₂O by the Kidney

Body water excess

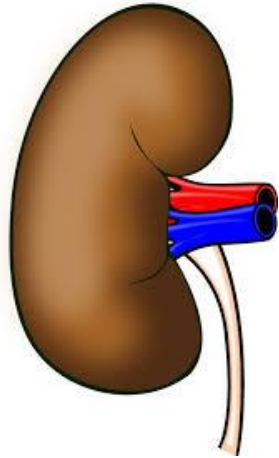

Large volume of diluted urine

Body water deficit

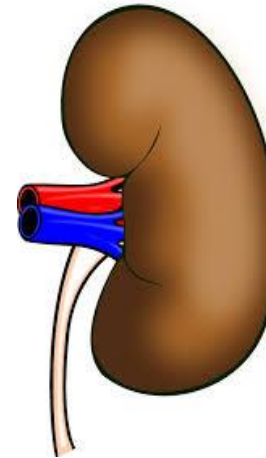

Small volume of concentrated urine

50 mOsm/L

Urine osmolarity

1200 mOsm/L

H₂O Handling by the Kidney

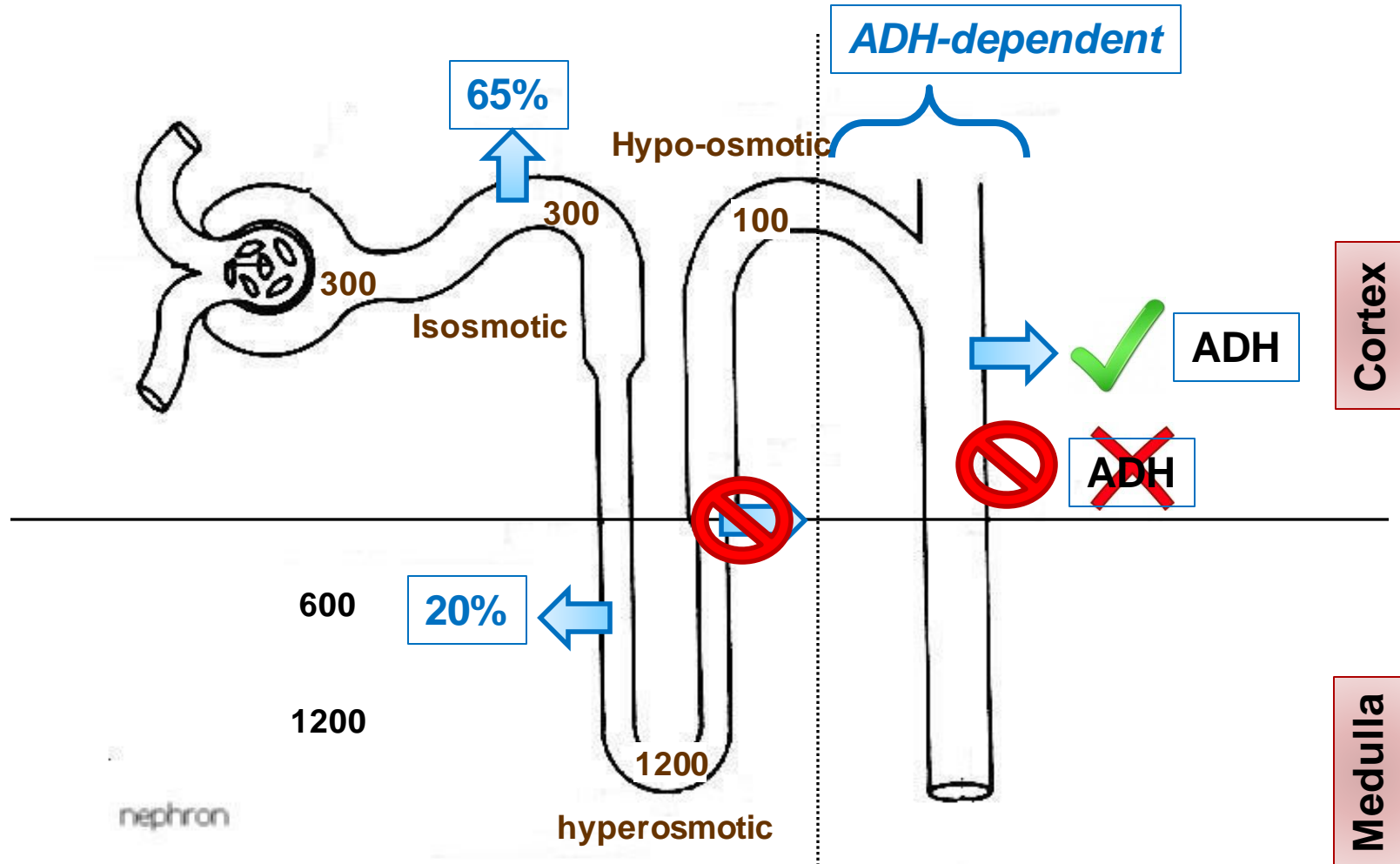

What happens to the osmolarity of tubular filtrate?

Obligatory urine volume

- The minimal volume of urine that must be excreted to rid the body of waste products of metabolism.
- It is determined by the maximal concentrating ability of the kidney.
- A 70-Kg human needs to excrete 600 mOsm of solutes per day.
- ***What is the obligatory urine volume?***

$$\frac{600 \text{ mOsm/d}}{1200 \text{ mOsm/L}} = 0.5 \text{ L/day}$$

Forming a Concentrated Urine

- ***Requires:***

1. High levels of ADH.
2. Hyperosmotic renal medulla.
 - a. Countercurrent mechanism.
 - b. Urea recirculation.

- IF around the body has an osmolarity of ≈ 300 mOsm/L..
How did the renal medullary interstitium become hyperosmotic?

Due to accumulation of NaCl & Urea in the renal interstitium

Countercurrent Multiplier Mechanism

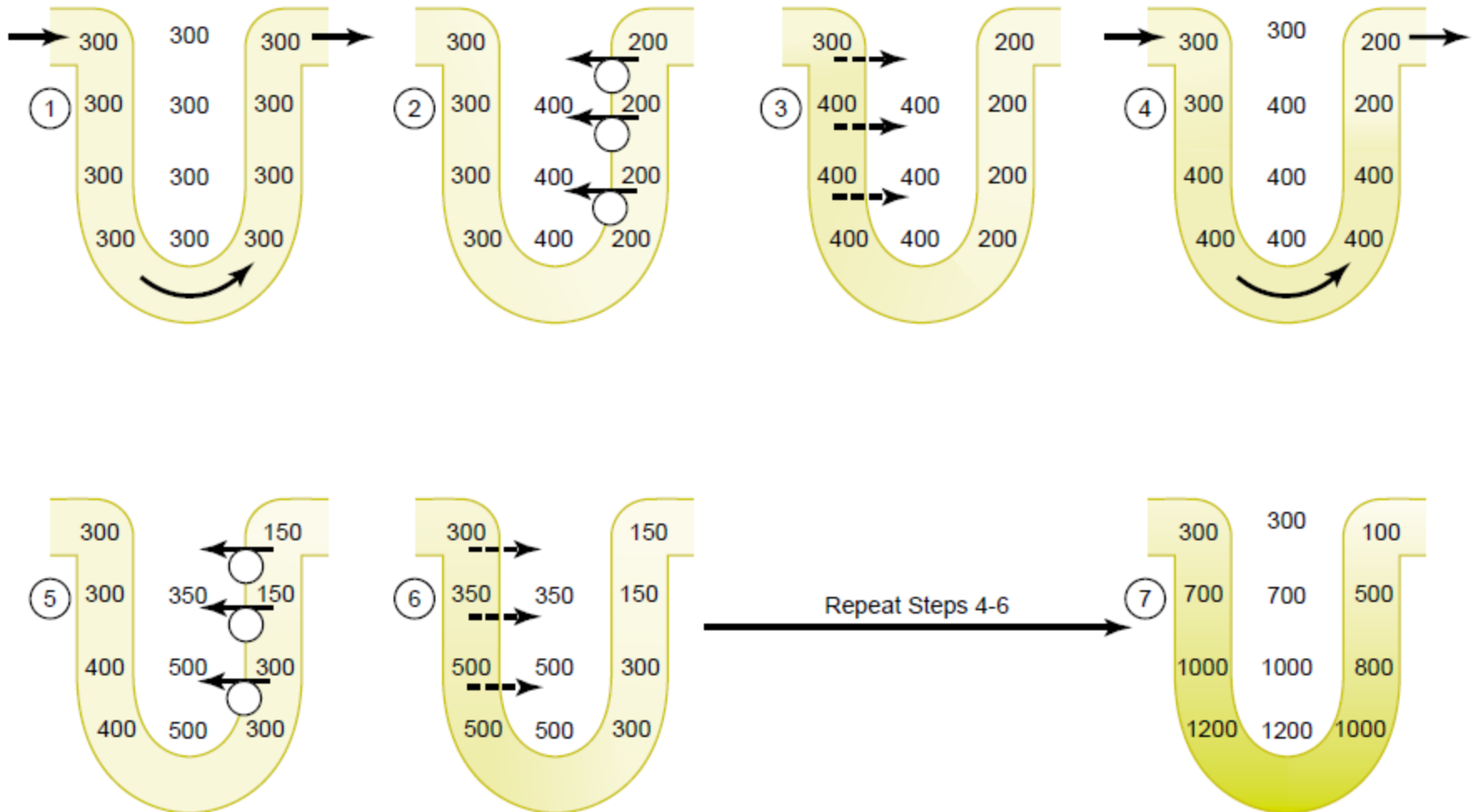
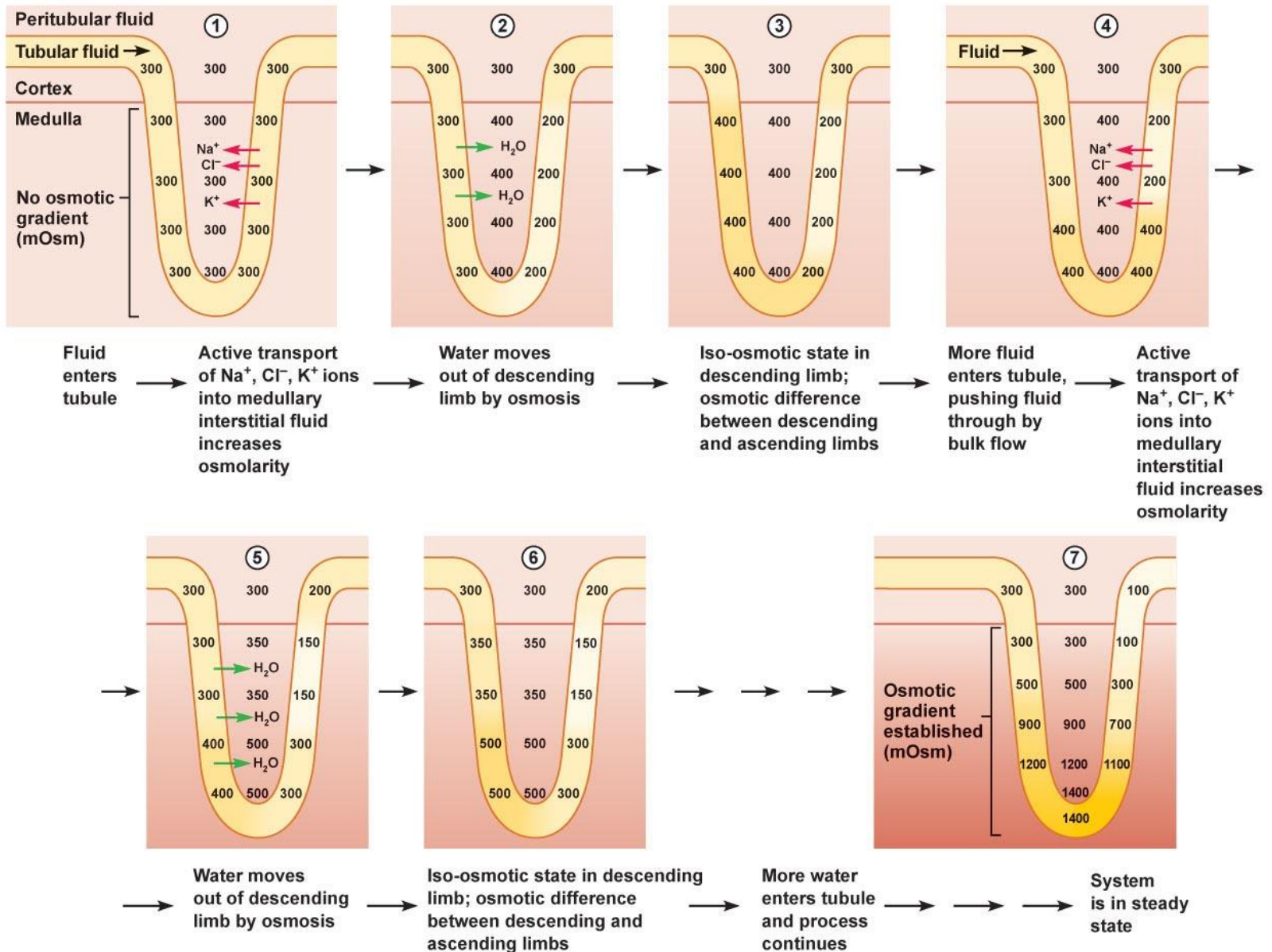

Figure 28-3

Countercurrent multiplier system in the loop of Henle for producing a hyperosmotic renal medulla. (Numerical values are in milliosmoles per liter.)

Countercurrent Multiplier Mechanism



Recirculation of Urea

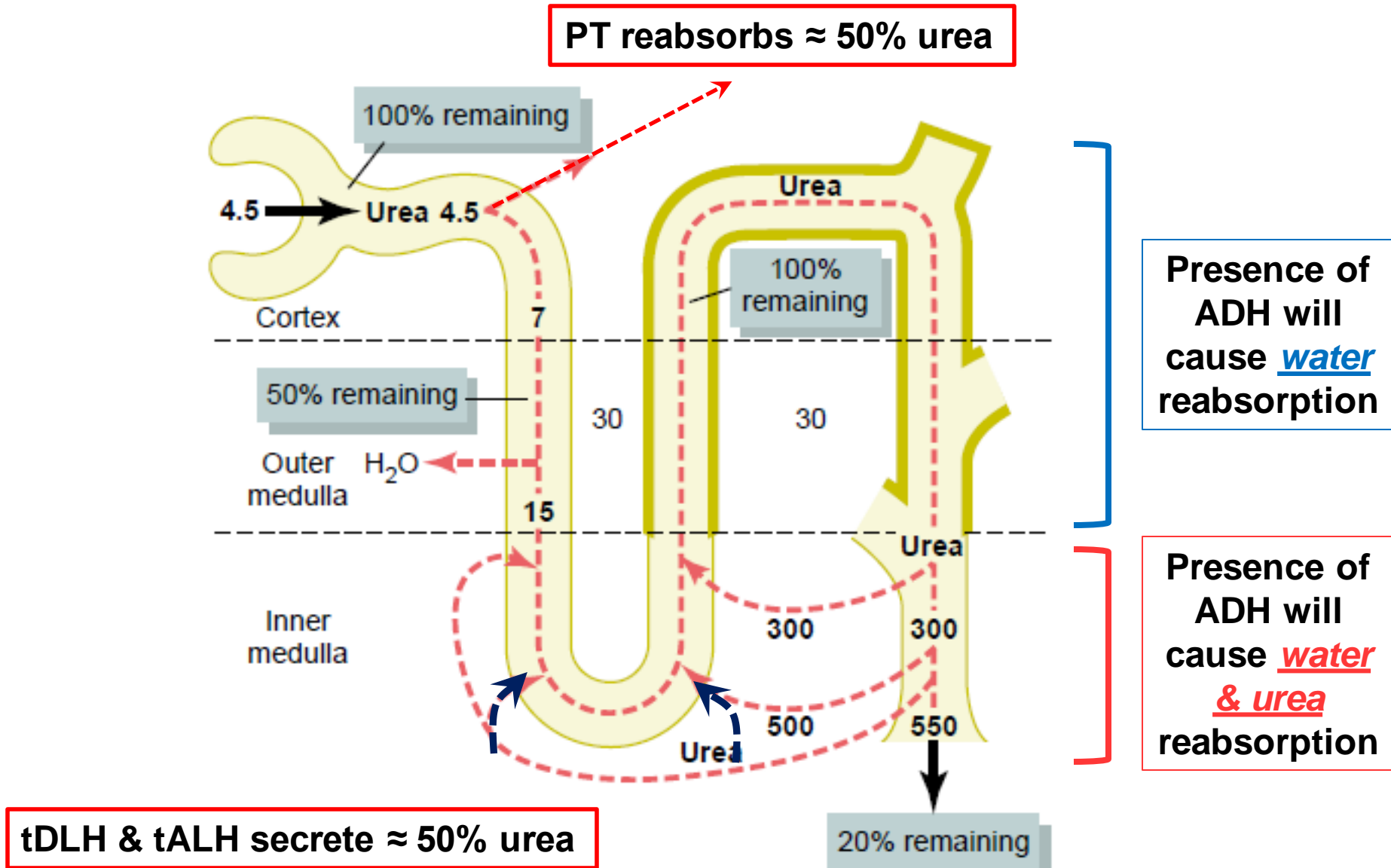

The Vasa Recta

- *Why doesn't the blood flowing through the vasa recta into the renal medulla wash out the medullary hyperosmotic gradient?*
 1. Medullary blood flow is low (<5%) of renal blood flow.
 2. The vasa recta serve as countercurrent exchangers.

The Vasa Recta Countercurrent exchanger

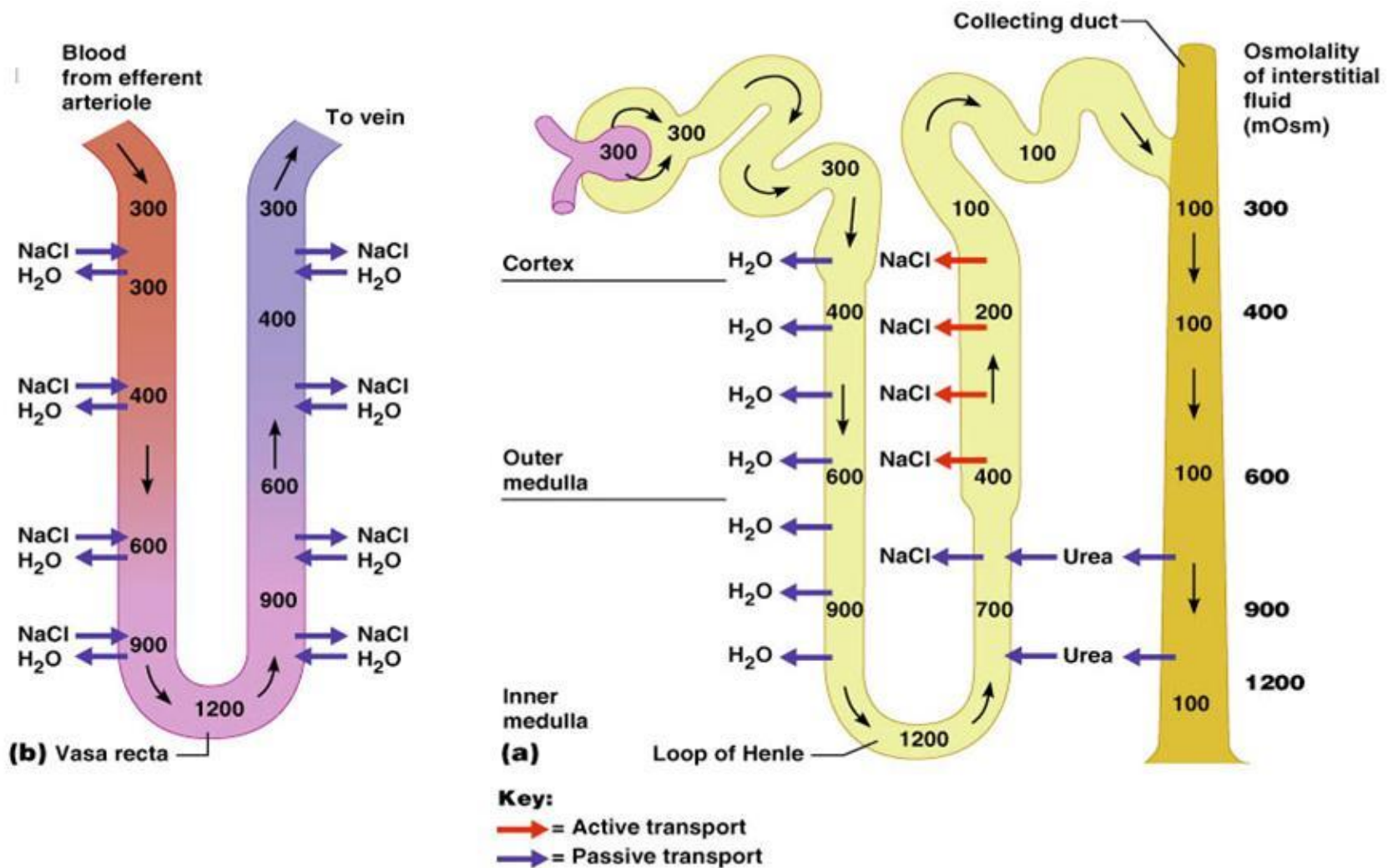

The Vasa Recta Countercurrent Exchanger

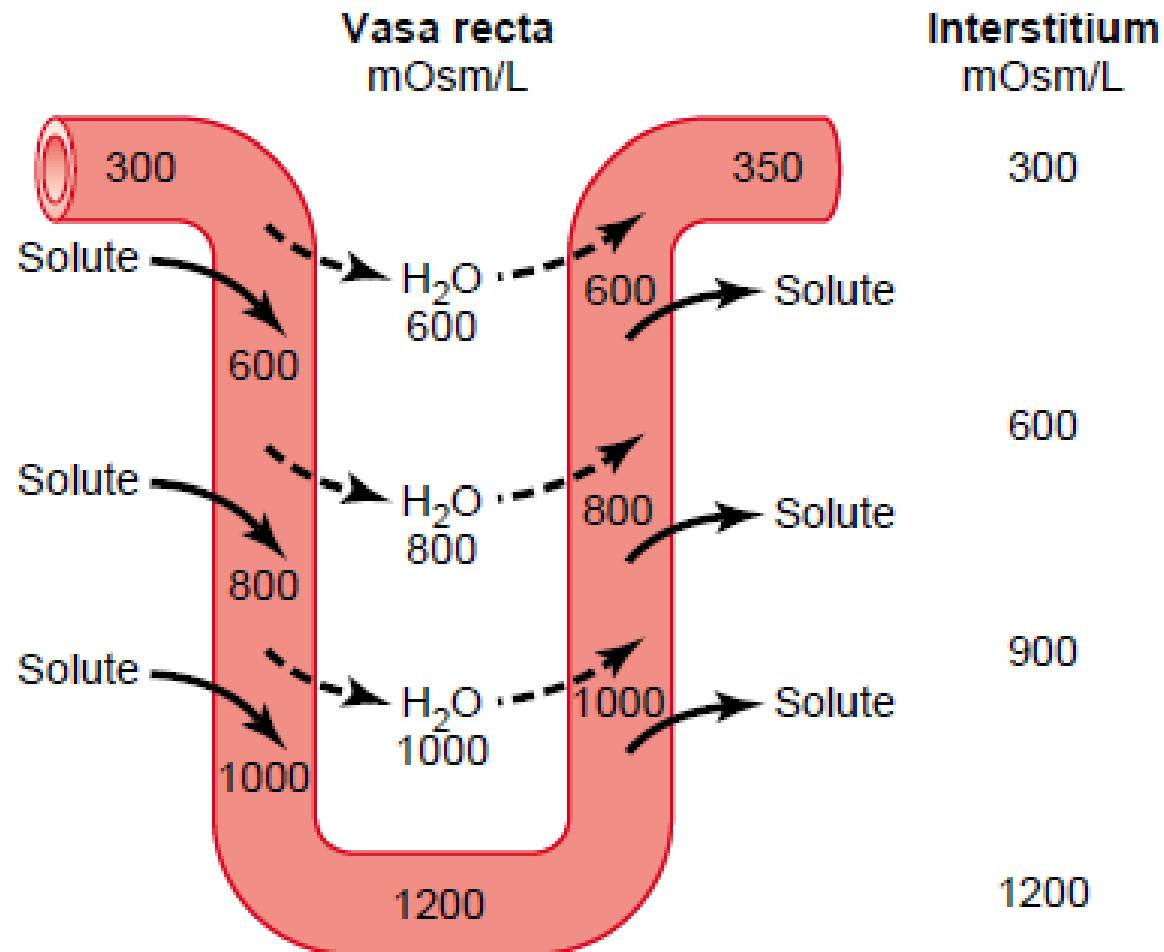

REGULATION OF ECF OSMOLARITY

Regulation of ECF Osmolarity

$$\text{Osmolarity} = \frac{\text{Amount of solute}}{\text{Volume of ECF}} \longrightarrow \boxed{\text{Water}}$$

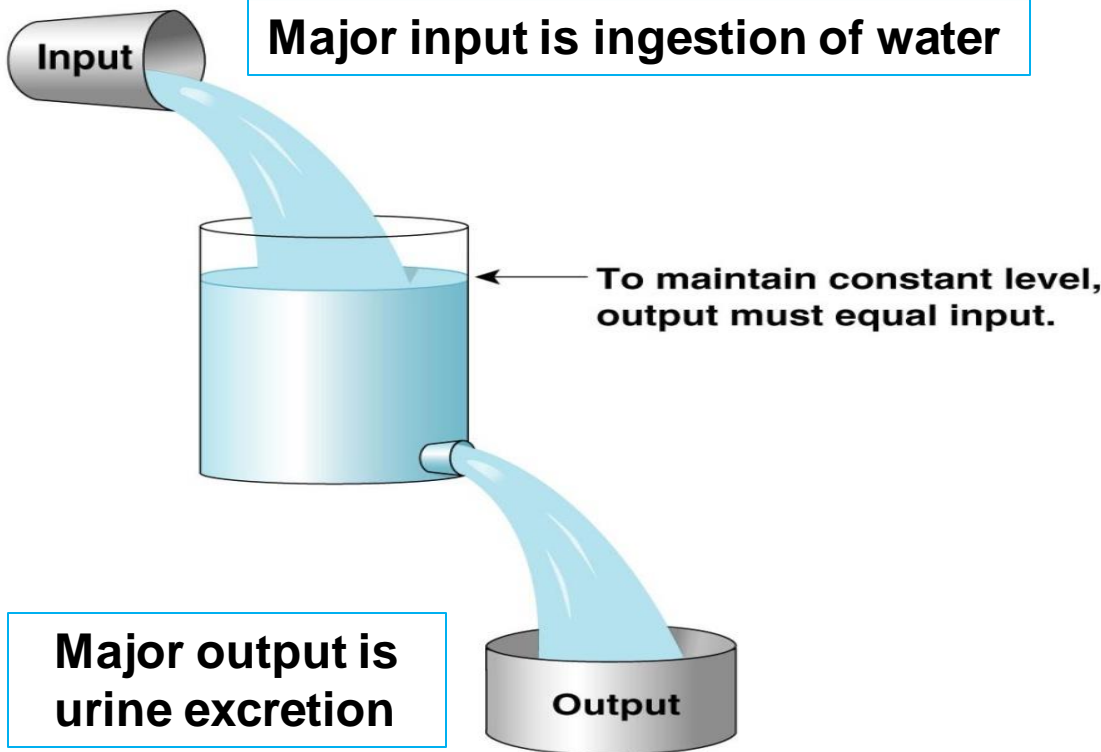

ECF osmolarity is regulated by two main mechanisms;

1. Thirst mechanism.
2. Osmoreceptor-ADH system.

Antidiuretic Hormone (ADH)

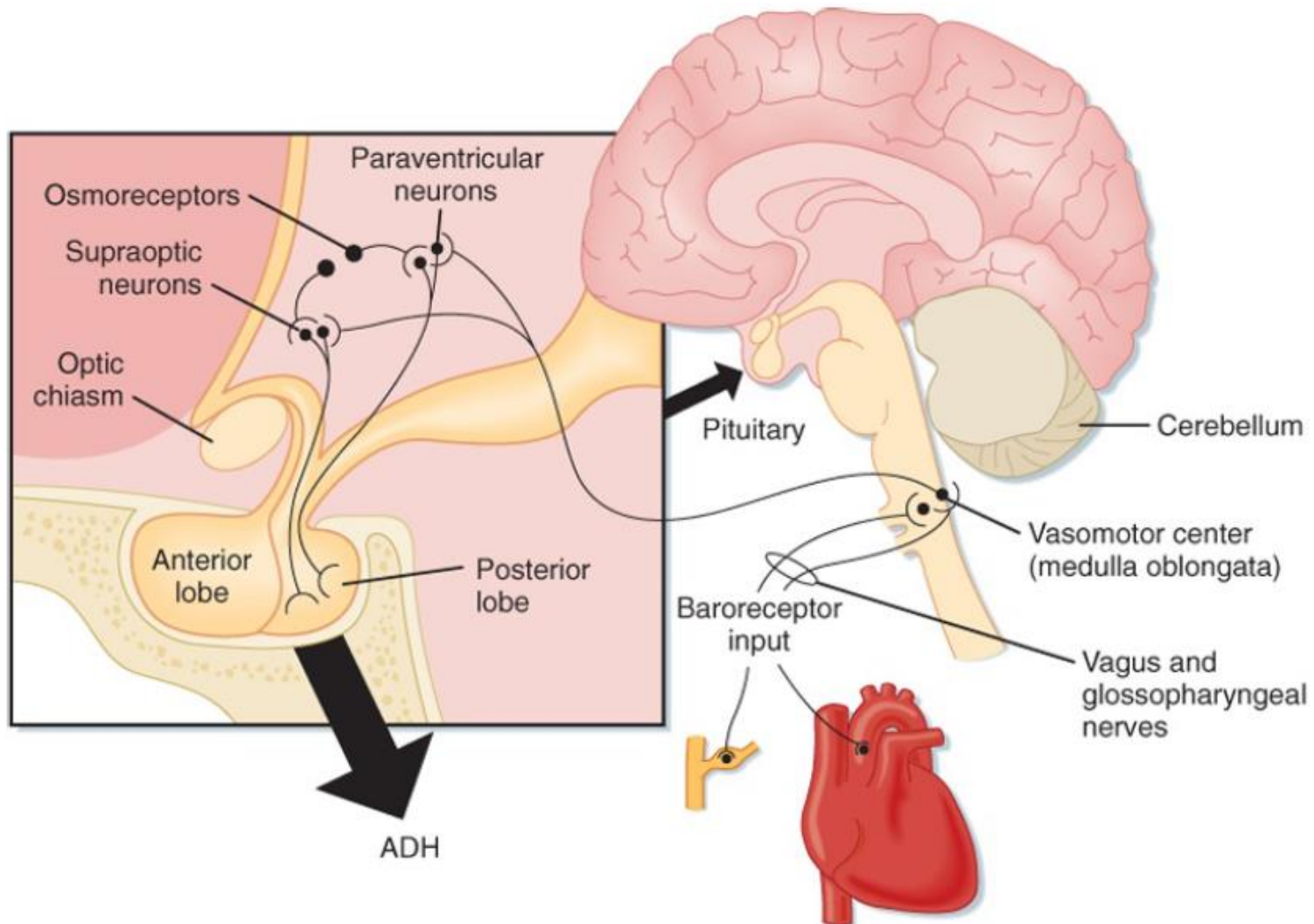

How Osmoreceptors Sense Changes in Osmolarity

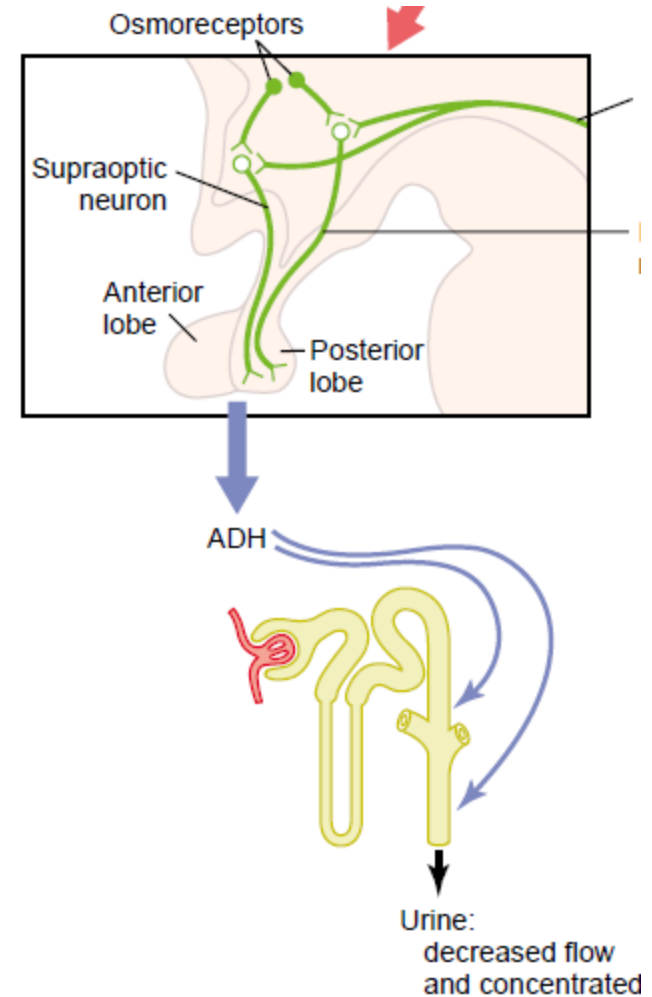
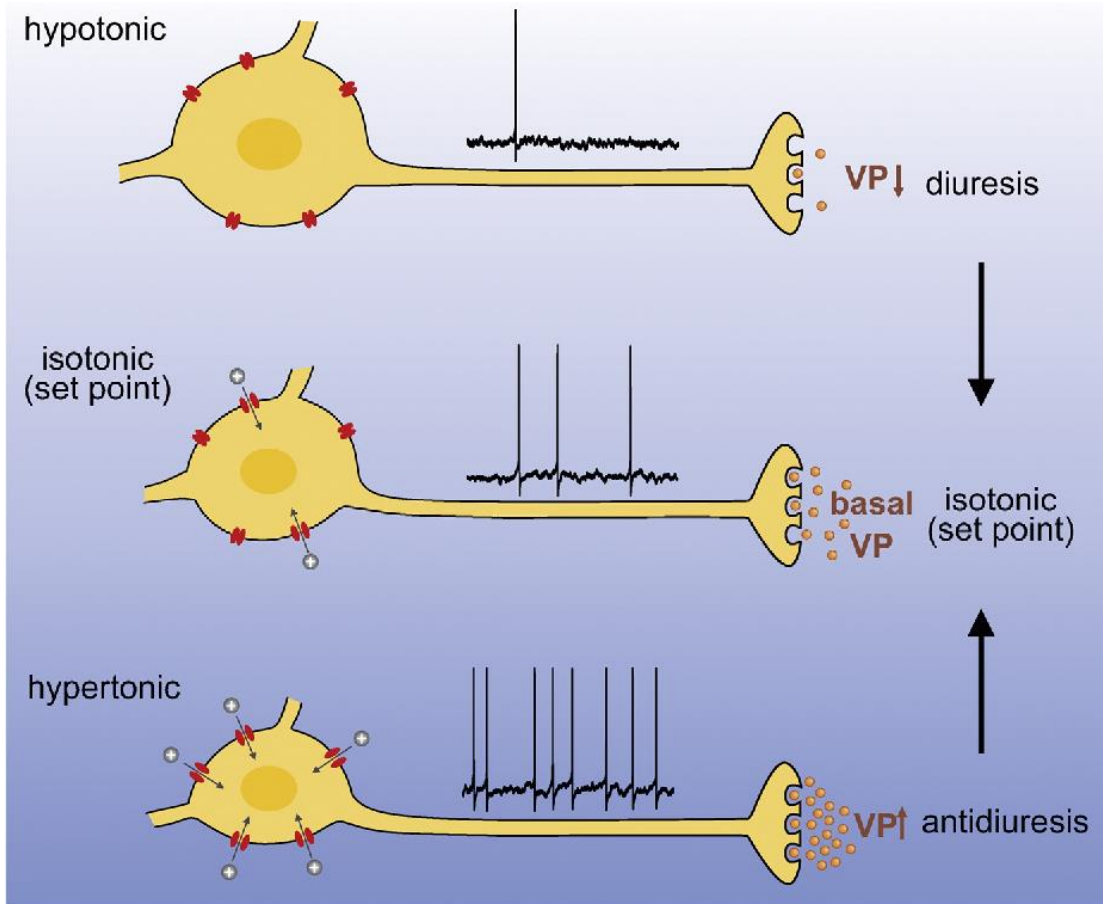

Mechanosensing in hypothalamic osmosensory neurons. [Masha Prager Khoutorsky](#).
Published in Seminars in cell...2017

Stimulants for ADH Secretion

- ***Osmotic*** (most important)
 - Osmolarity of ECF.
 - 1% change in osmolarity can alter ADH secretion significantly.
- ***Hemodynamic***
 - Blood volume & arterial blood pressure in the vascular system.
 - 5-10% decrease in ABP or BV is required before ADH secretion is stimulated.

Factors That Can Alter ADH Secretion

Increase ADH	Decrease ADH
Nausea	ANP
Hypoxia	
Angiotensin-II	
Drugs; Morphine Nicotine	Drugs; Alcohol

ADH Mechanism of Action

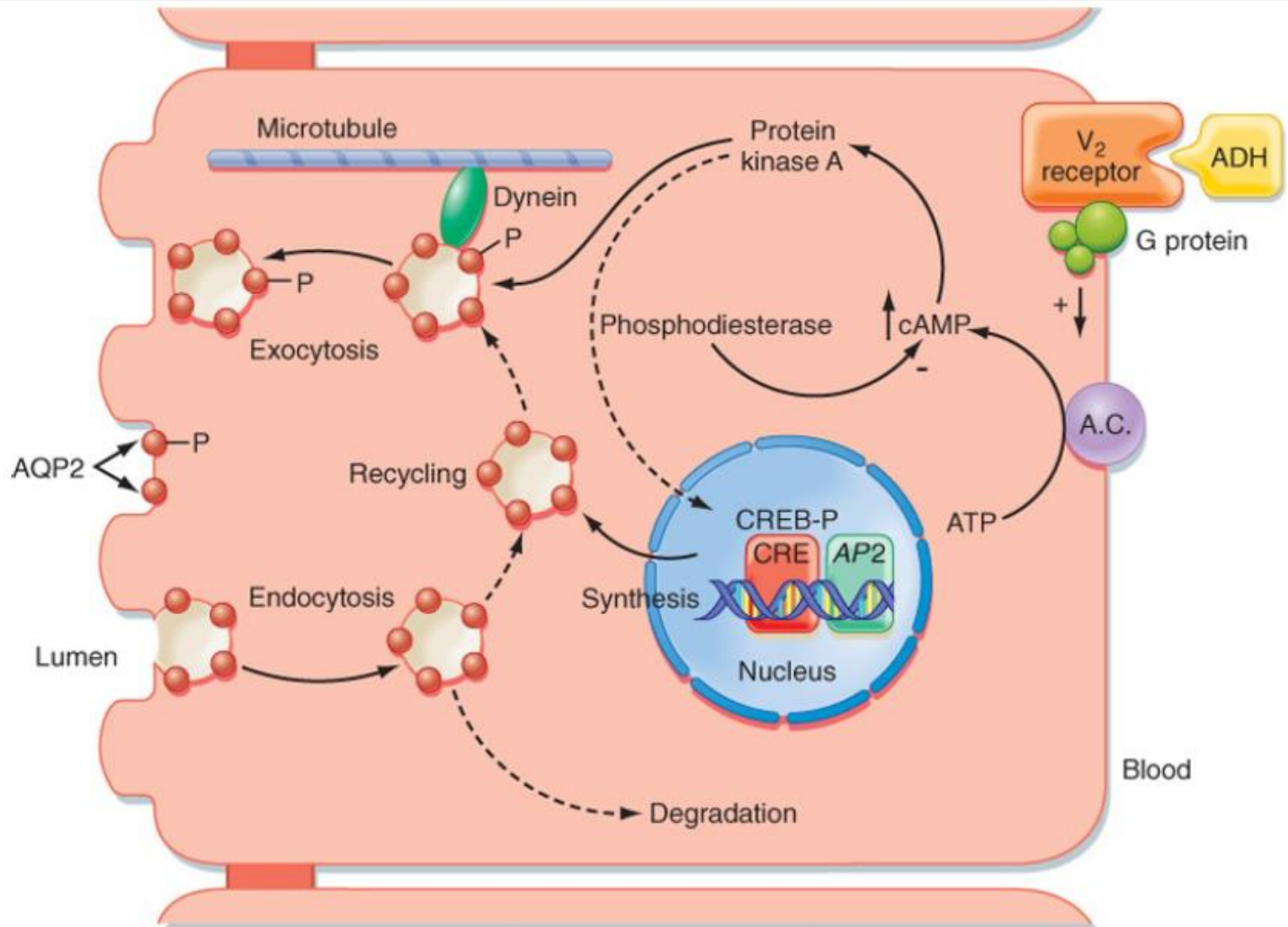

Water Balance

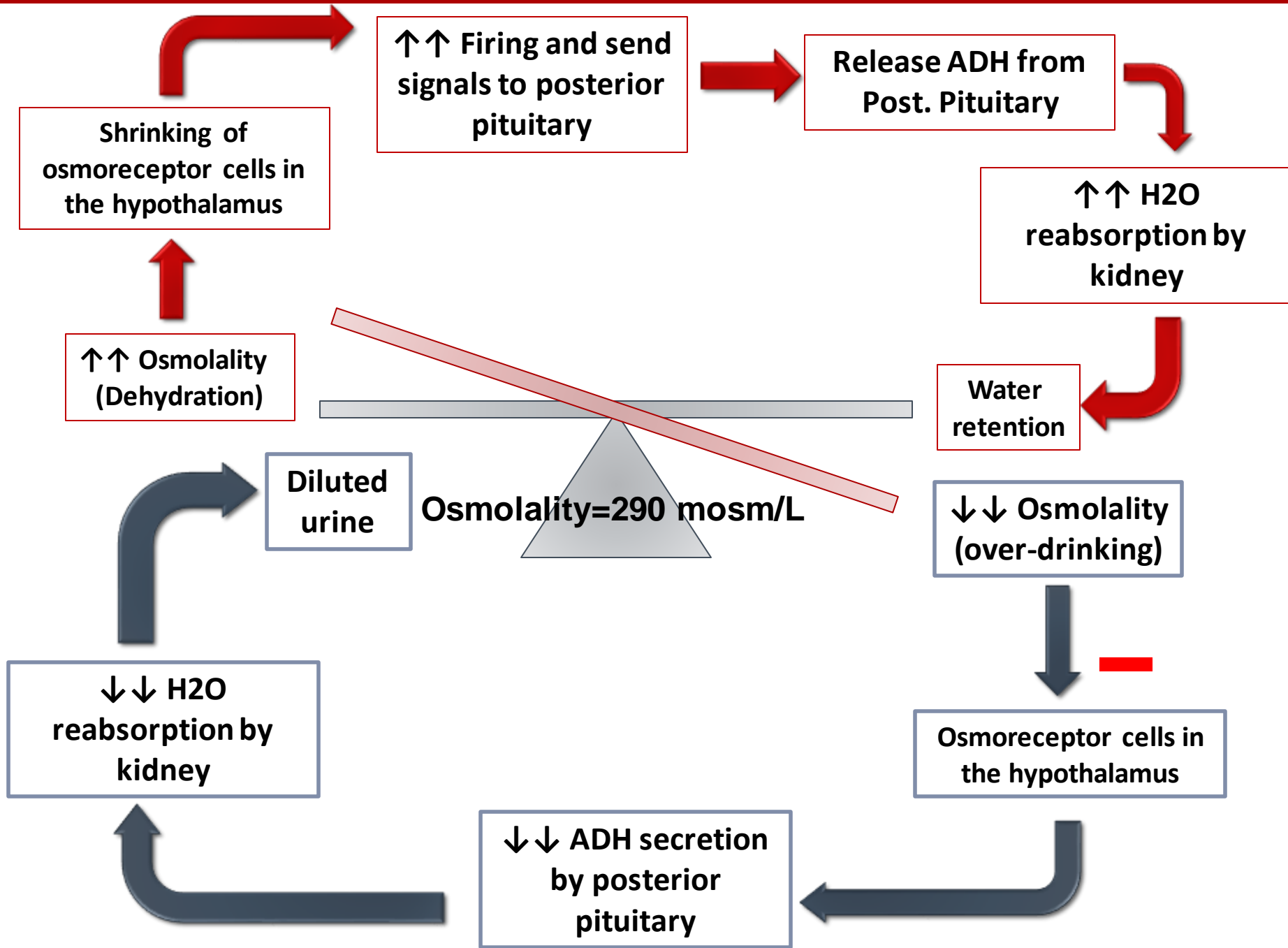

Thirst Mechanism

- Thirst is the conscious desire for water.

Table 28-3

Control of Thirst

Increase Thirst

↑ Osmolarity
↓ Blood volume
↓ Blood pressure
↑ Angiotensin

Dryness of mouth

Decrease Thirst

↓ Osmolarity
↑ Blood volume
↑ Blood pressure
↓ Angiotensin II

Gastric distention

Importance of thirst and ADH mechanisms in regulating ECF osmolarity is highlighted in the opposite graph.

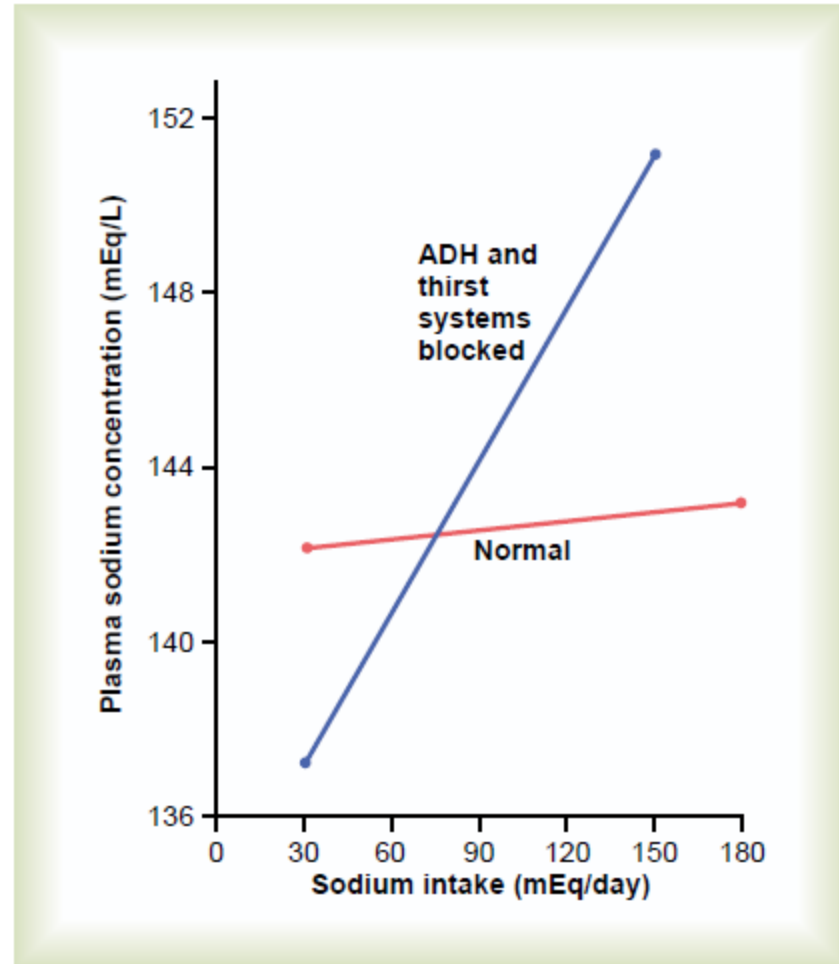
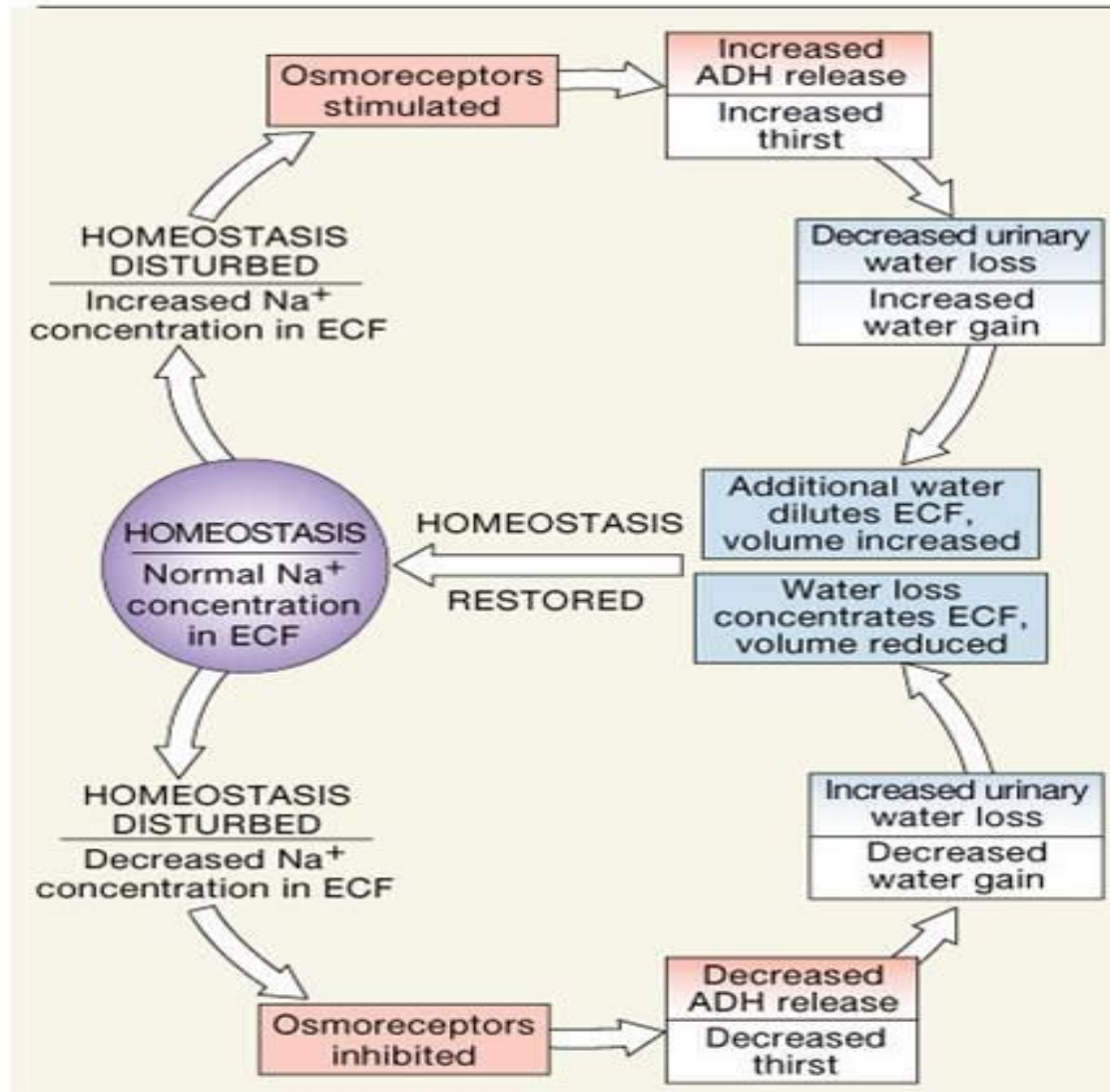

Figure 28-11

Effect of large changes in sodium intake on extracellular fluid sodium concentration in dogs under normal conditions (*red line*) and after the antidiuretic hormone (ADH) and thirst feedback systems had been blocked (*blue line*). Note that control of extracellular fluid sodium concentration is poor in the absence of these feedback systems. (Courtesy Dr. David B. Young.)

Feedback Mechanisms Involved in Regulation of Water Balance



Abnormalities in ADH Secretion

Abnormalities in ADH secretion

Inadequate ADH effect
“*Diabetes insipidus*”

Excessive ADH
“*SIADH*”

Central

↓↓ ADH from
posterior pituitary.
Polyuria
Polydipsia

Nephrogenic

Mutations in V2
receptors or AQP2.
Cannot respond to
ADH.
Polyuria
Polydipsia

High ADH levels.
Water retention.
ECF hypo-osmotic
Urine hyperosmotic

Water Diuresis vs Osmotic Diuresis

Water diuresis	Osmotic diuresis
Increased urine flow rate (No change in urine excretion of solutes)	Increase urine flow rate as well as the excretion of solutes
<p>Causes:</p> <ul style="list-style-type: none"> - Excess ingestion of water - Lack of ADH - Defect in ADH receptors in Distal segment of nephron (nephrogenic Diabetes Insipidus) 	<p>Causes:</p> <ul style="list-style-type: none"> - Increase plasma glucose level (DM) - Increase level of poorly reabsorbed solutes/ anions - Diuretic drugs (Lasix)
Diuresis is mainly due to decrease in water reabsorption in distal segment of nephron. No change to the water reabsorbed proximally	Diuresis is mainly due to decrease reabsorption of solute in PCT or LOH. Decrease solute reabsorption results in decrease in water reabsorption proximally as well as distally

Water Diuresis vs Osmotic Diuresis

Water diuresis	Osmotic diuresis
Increase urine volume results from increased excretion of pure water	Increase urine volume results from increased excretion of osmotically active solutes which pulls water with it.
Urine osmolality falls far below plasma osmolality.	Urine osmolality falls but remains above plasma osmolality.
Only about 15% filtered load of water reaching distal segments may remain unabsorbed and excreted in urine (maximum urine volume 20 ml/min)	Due to decreased water reabsorption in all segments of nephron, a much greater fraction of filtered water may be excreted volume more than 20 ml/min
ADH administration will stop diuresis if it is due to lack of ADH. ADH administration will not be effective in Nephrogenic Diabetes Insipidus.	ADH administration will not stop diuresis.

THANK YOU
