

FEBRUARY 26, 2022

# **CARDIOVASCULAR PHYSIOLOGY**

**Asma Alyahya, MBBS, PhD**

CONTRACTILE MECHANISM IN CARDIAC MUSCLE

## Objectives

- Define cardiac muscle contractility & types of its contraction
- Understand the physiology of cardiac muscle
- Understand the phases of cardiac action potential and the ionic bases
- Identify the refractory period of cardiac muscle
- Discuss the role of  $Ca^{++}$  in the regulation of cardiac muscle function
- Describe the mechanism of excitation contraction coupling
- Discuss factors affecting cardiac contractility

Ref: Guyton and Hall

## CARDIOVASCULAR PHYSIOLOGY FUNCTIONS OF THE CVS

### Primary function of cardiovascular system:

- Deliver blood to tissues  
Providing essential nutrients *to*  
cells for metabolism  
Removing waste products.

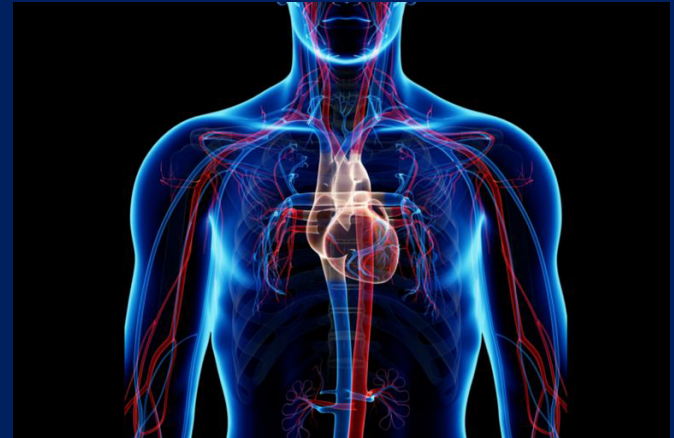

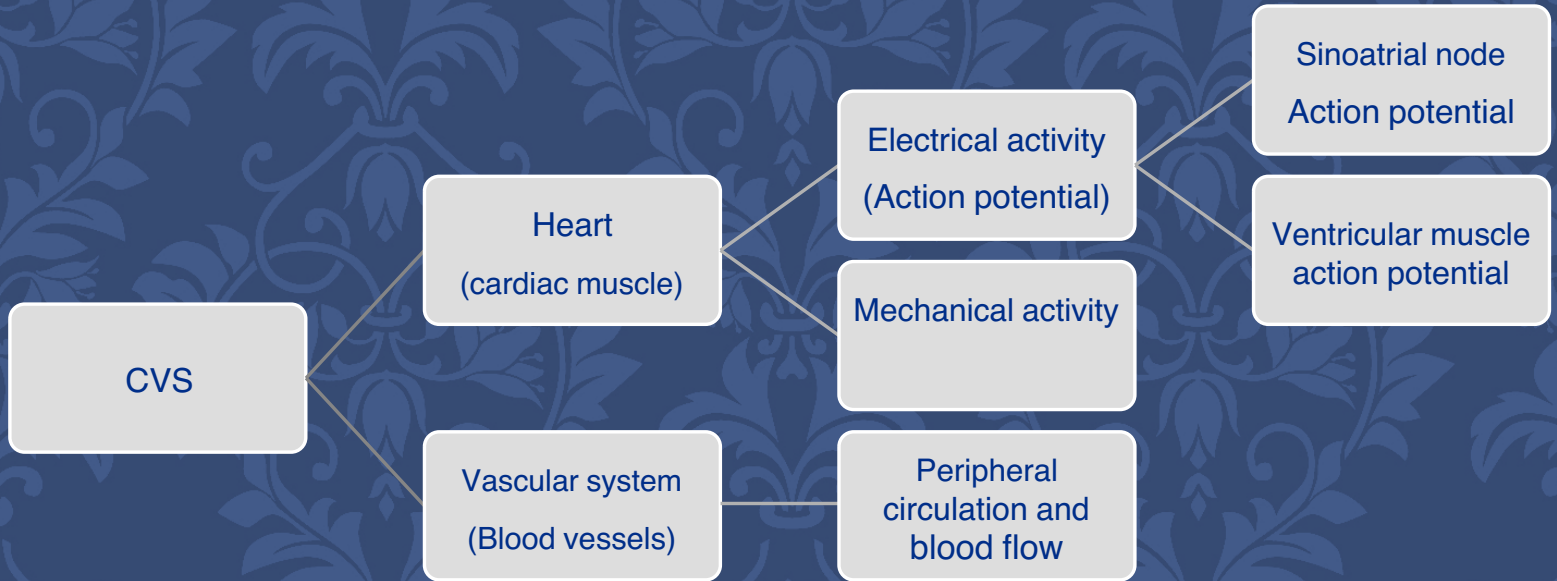



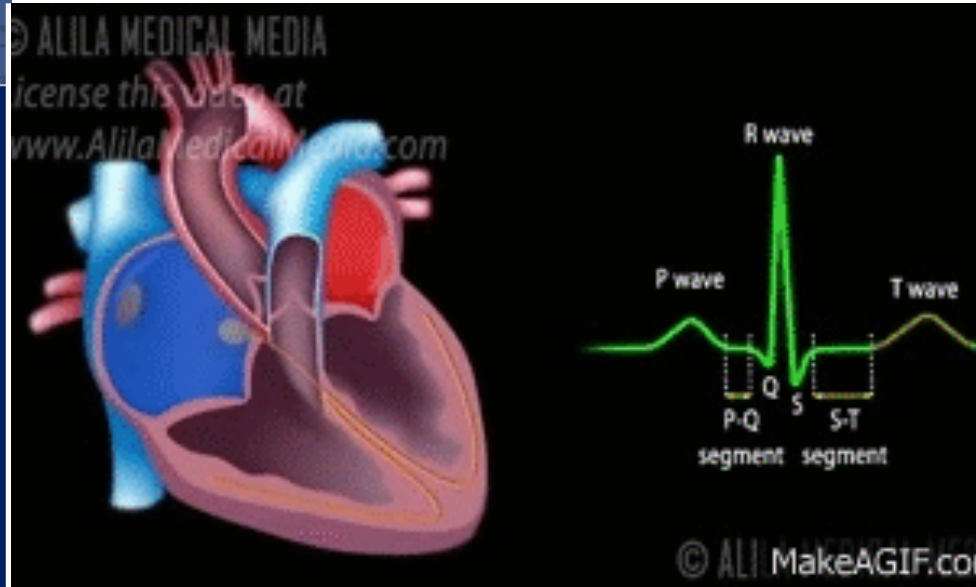

The heart muscle is remarkable. At an average heart rate of 70 beats/min , the heart needs to contract and relax more than 100 000 times a day without stopping or tiring.

## PHYSIOLOGIC ANATOMY OF CARDIAC MUSCLE

- Cardiac muscle cells are found only in the heart, are specialized to pump blood powerfully and efficiently throughout our entire lifetime.
- **Contractility** describes the relative ability of the heart to eject a stroke volume (pump blood)

**Characteristics of cardiac muscle tissue cells :**

**involuntary**

**intrinsically controlled**

**striated**

Branched and **single nucleated**.

Cardiac muscle fibers are **striated**

**Each muscle fiber is made up of**

1. **Sarcolemma**: muscle fiber plasma (cell) membrane
2. **Sarcoplasm**: the muscle fiber cytoplasm
3. **Sarcoplasmic Reticulum**: smooth endoplasmic reticulum (SER)
4. **Transverse Tubules**: tubules formed by invaginations of the sarcolemma and flanked by the sarcoplasmic reticulum
5. **Myofibril**
6. **Myofilaments**
7. **Sarcomere**: Is the smallest contractile unit of a muscle fiber, a compartment of myofibrils

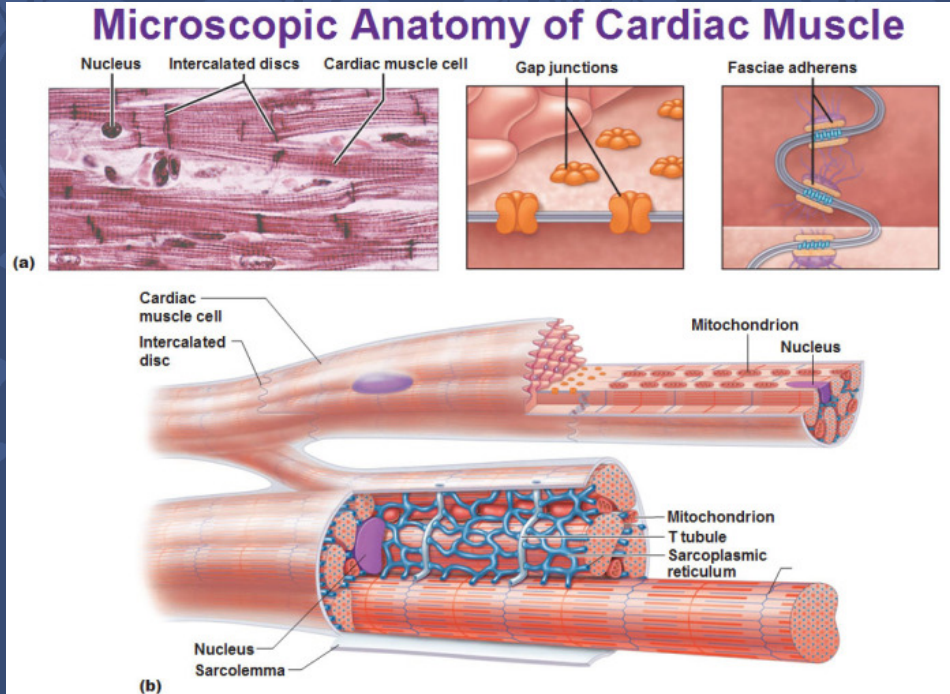

## PHYSIOLOGIC ANATOMY OF CARDIAC MUSCLE

- Branched and connected at **intercalated discs**.
- Discs contain **Gap Junctions**
- Nuclei are centrally located
- **Abundant** Mitochondria
- SR is less than in skeletal muscle, but greater than in smooth muscle
- Sarcolemma: Has specialized ion channels that skeletal muscle does not ( – voltage-gated  $\text{Ca}^{2+}$  channels)
- Fibers are not anchored at ends; allows for greater sarcomere shortening and lengthening

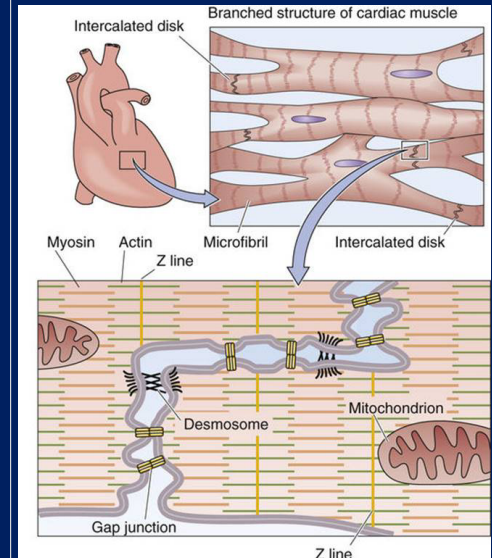

## CARDIAC MUSCLE AS A SYNCYTIUM

### Intercalated discs:

- Dark areas cross cardiac muscle
- Are cell membranes that separate muscle cells.
- Membranes fuse and form permeable **gap junctions** which allow:

AP pass easily

Formation of syncytium

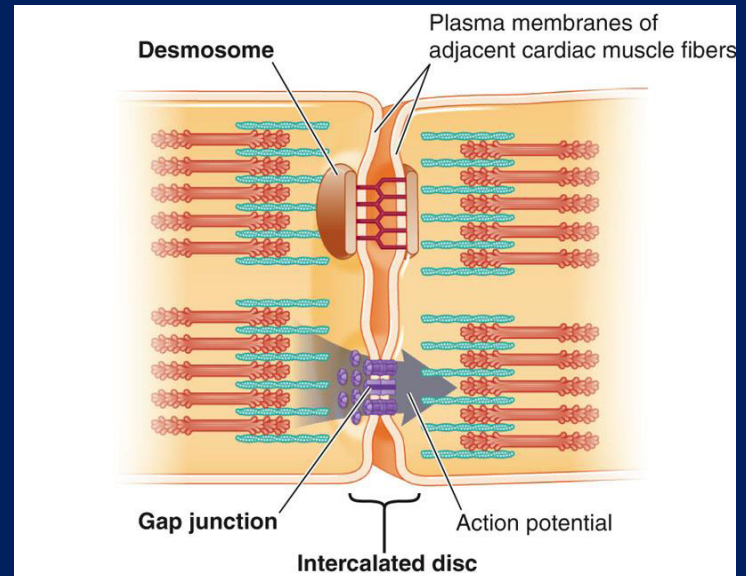

Within intercalated discs –two kinds of membrane junctions:

1. Desmosomes (anchoring)
2. Gap junctions



## FEATURES OF DIFFERENT TYPES OF MUSCLE

Table III-2-1. Histologic Features of Skeletal, Cardiac, and Smooth Muscle

Skeletal	Cardiac	Smooth
Striated	Striated	Nonstriated
Actin and myosin form sarcomeres	Actin and myosin form sarcomeres	Actin and myosin not organized into sarcomeres
Sarcolemma lacks junctional complexes between fibers	Junctional complexes between fibers including gap junctions	Gap junctions
Each fiber innervated	Electrical syncytium	Electrical syncytium
Troponin to bind calcium	Troponin to bind calcium	Calmodulin to bind calcium
High ATPase activity (fast muscle)	Intermediate ATPase activity	Low ATPase activity (slow muscle)
Extensive sarcoplasmic reticulum	Intermediate sarcoplasmic reticulum	Limited sarcoplasmic reticulum
T tubules form triadic contacts with reticulum at A-I junctions	T tubules form dyadic contact with reticulum near Z lines	Lack T tubules, SR controlled by second messengers
Surface membrane lacks calcium channels	Voltage-gated calcium channels	Voltage-gated calcium channels

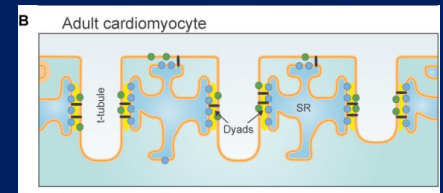

## PHYSIOLOGY OF CARDIAC MUSCLE

- **Heart has 3 types of muscle:**

Atrial

Ventricular

Excitatory and conductive

### *What's the difference between cardiac and skeletal muscle contraction?*

- Atrial and ventricular muscle contract in the same way as skeletal muscle, except that **duration of contraction is much longer in cardiac muscle**.

## PHYSIOLOGY OF CARDIAC MUSCLE..

### Specialized excitatory and conductive fibers

#### Types:

**Automatic** rhythmical electrical discharge in form of APs  
(SA node)

**Conduction** of APs through heart (conductive fibers)



## CARDIAC MUSCLE PROPERTIES

The cardiac muscle cells are responsible for electrical stimulation which leads to mechanical function. *The electro-physiologic properties of cardiac muscles are:*

- **Automaticity:** Ability to spontaneously generate an electrical impulse.
- **Excitability:** Ability to respond to an electrical impulse.
- **Conductivity:** Allow transmission of electrical impulse to another cardiac cell.
- **Contractility:** Ability to contract after electrical impulse response
- **Rhythmicity:** Ability to send electrical impulses in a regularly manner.

## TYPES OF CARDIAC MUSCLE CELLS

### 1. Contractile cells

- 99% of cardiac muscle cells
- Perform mechanical work of pumping

### 2. Autorhythmic cells

- Specialized for initiating and conducting action potentials responsible for contraction of myocytes
- Do not contract

## CARDIAC MUSCLE AS A SYNCYTIUM

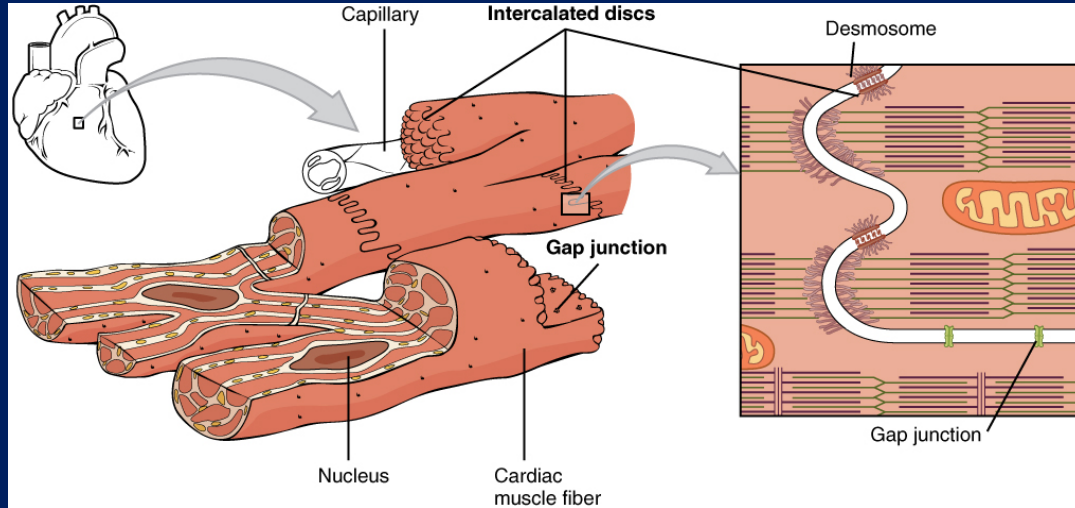

### How do gap junctions within intercalated discs aid contraction of the heart?

They allow impulses to spread from one cardiac muscle cell to another, allowing sodium, potassium, and calcium ions to flow between adjacent cells, propagating the action potential, and ensuring coordinated contractions.

## CARDIAC MUSCLE AS A SYNCYTIUM

### Heart is composed of two syncytium:

1. Atrial
  2. Ventricular
- Separated by **fibrous tissue**.
  - ***What's the importance of this separation?***
  - Allows atria to contract ahead of ventricles
  - ***How do action potentials reach ventricles?***
  - Action Potentials are conducted by A-V bundle.

**CARDIAC MUSCLE MECHANICS  
ISOMETRIC AND ISOTONIC  
CONDITION**

- Cardiac muscle goes through the same series of isometric and isotonic events as skeletal muscle.
- Therefore, the cardiac cycle (Heart beat) has two phases which are considered to be **isometric** (Isovolumic contraction, and Isovolumic relaxation) while all the other phases are considered to be **isotonic** in nature.

FEBRUARY 26, 2022



Of the three types of muscle  
tissue, **cardiac muscle tissue** is  
the one that's near and dear to  
my heart because, well, **it's in  
my heart!**

18

MEDICAL CVS

## EXCITATION-CONTRACTION COUPLING

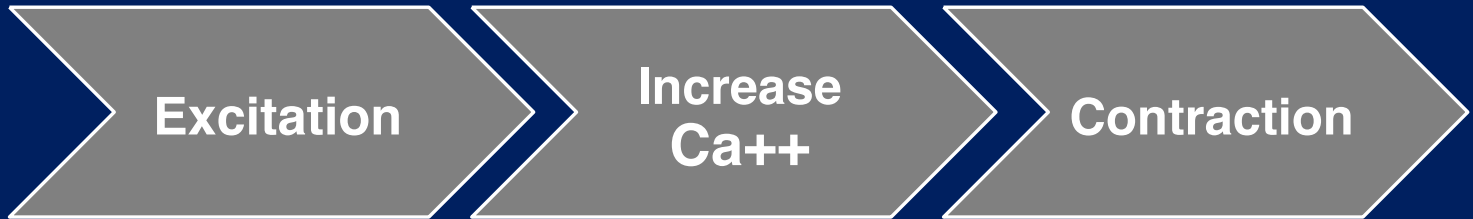

Excitation of the heart is triggered by electrical impulse rather than neural transmitters.

Contraction of the heart is triggered by elevation of intracellular calcium influx.

**ACTION POTENTIALS OF VENTRICLES, ATRIA, AND  
THE PURKINJE SYSTEM  
POTENTIAL IN CARDIAC MUSCLE**

The ionic basis for the Aps in the ventricles, atria, and Purkinje system is identical. The AP in these tissues shares the following characteristics:

Long duration

Stable resting membrane potential

Plateau



## ACTION POTENTIAL IN CARDIAC MUSCLE (VENTRICLES)

Phase 0: Depolarization, fast  
 $\text{Na}^+$ (influx)

Phase 1: early repolarization,  $\text{K}^+$  efflux

Phase 2: Plateau = 0.2 sec, slow  $\text{Ca}^{++}$   
channels open causing  $\text{Ca}^{++}$  influx

Phase 3: Repolarization:  $\text{K}^+$  efflux

Phase 4: Resting,  $\text{K}^+$  efflux

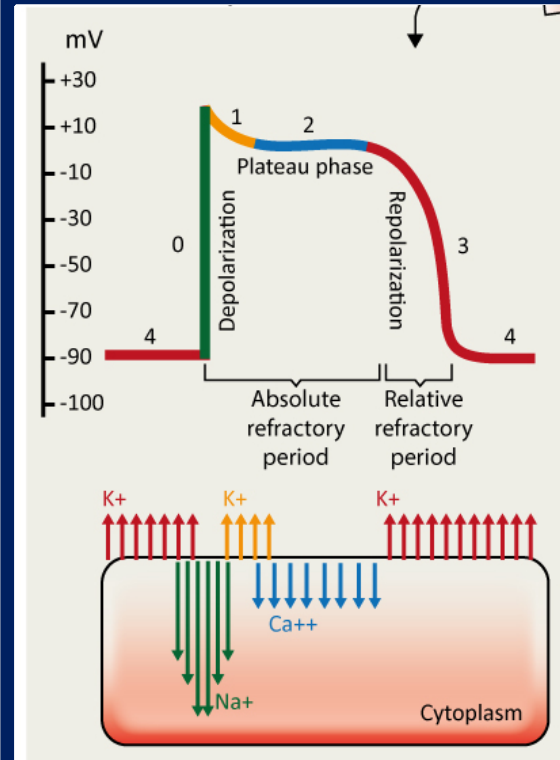

## Why is the plateau phase is critical to cardiac muscle function ?

- It causes ventricular contraction to last as much as 15 times as long in cardiac muscle as in skeletal muscle.
- It prevents additional impulses from spreading through the heart prematurely, thereby allowing the muscle sufficient time to contract and pump blood effectively.

### What causes the plateau?

- Prolonged opening of the slow calcium-channels allows calcium to enter, cause plateau.

## DIFFERENCE BETWEEN ACTION POTENTIAL IN SKELETAL AND CARDIAC MUSCLE

### Skeletal muscle

#### First:

• AP is caused by sudden opening of large numbers of fast Na<sup>+</sup> channels.

### Cardiac muscle

#### First:

AP is caused by opening of 2 channels:  
(1) fast Na<sup>+</sup> channels (same as in skeletal muscle and

(2) slow Ca<sup>2+</sup> channels (also called Ca<sup>2+</sup>-Na<sup>+</sup> channels or long lasting).

## DIFFERENCE BETWEEN ACTION POTENTIAL IN SKELETAL AND CARDIAC MUSCLE

### Skeletal muscle

#### Second:

- At end of closure, repolarization occurs due to **K<sup>+</sup> out flux (efflux)**, and AP is over within a thousandth of a second.

### Cardiac muscle

#### Second:

- After onset of AP, membrane permeability for **K<sup>+</sup>** ↓ **fivefold** (does not occur in skeletal muscle).
- **Decreased K<sup>+</sup> permeability ↓ out flux of K<sup>+</sup>** during plateau and prevents return of AP voltage to resting level.
- When slow **Ca<sup>+2</sup>** channels close, **K<sup>+</sup>** permeability ↑ rapidly returning membrane potential to resting level, ending AP.

# Difference between action potential of cardiac and skeletal muscle

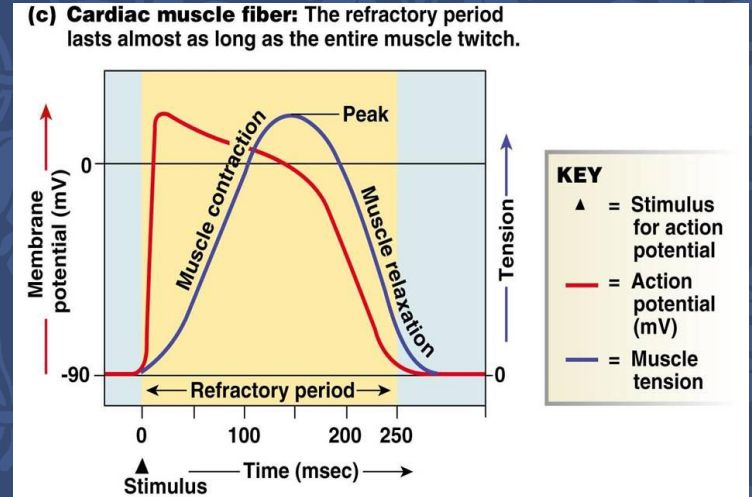
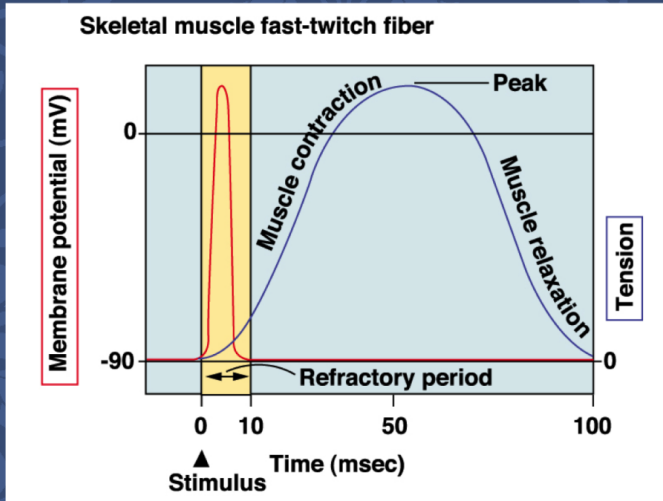

- In skeletal muscle, duration of AP is **shorter** than its mechanical response.
- This means that skeletal muscle can undergo tetanus via repeated stimulation

- In cardiac muscle, duration of AP is **same** as duration of its mechanical response.
- This means that cardiac muscle cannot undergo tetanus via repeated stimulation

## REFRACTORY (RESISTANT) PERIOD OF CARDIAC MUSCLE

**Absolute Refractory period (ARP) of ventricle:**  
**0.25 -0.30 sec ( signal cannot re-excite an already excited area of cardiac muscle)**

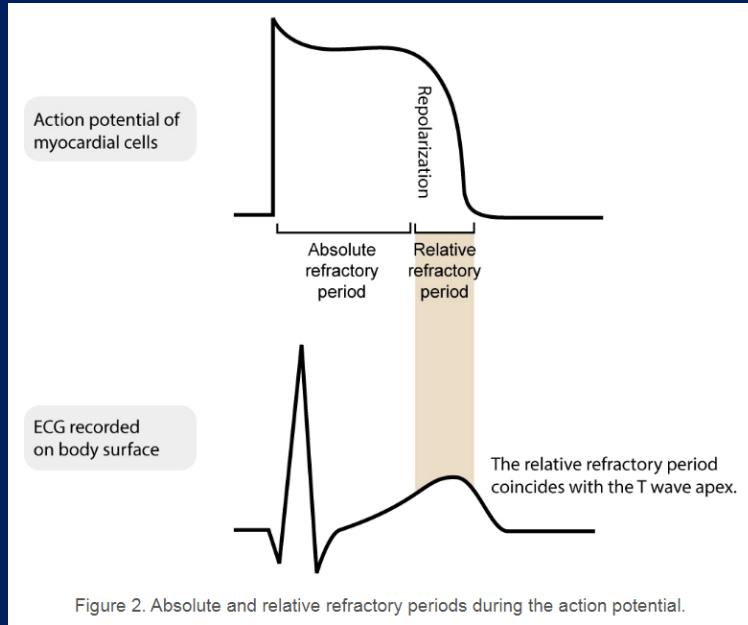

**Relative refractory period (RRP) of ventricle:**  
**0.05 sec (muscle difficult to excite but can be excited by a strong signal “premature” contraction)**

The ARP acts as a protective mechanism in the heart

## EXCITATION-CONTRACTION COUPLING IN CARDIAC MUSCLE

- Cardiac muscle fibers contract via excitation-contraction coupling, using a mechanism unique to cardiac muscle called **calcium -induced calcium release (CICR)** .
- Calcium-induced calcium release involves the conduction of calcium ions into the cardiomyocyte, triggering further release of ions into the cytoplasm.

## EXCITATION-CONTRACTION COUPLING...

- 1. AP** is initiated in cell membrane, and depolarization spreads to interior of cell via T tubules.
- 2. Entry of  $\text{Ca}^{++}$  triggers release of more  $\text{Ca}^{2+}$  from SR through ryanodine receptors.**
- 3 and 4.**  $\text{Ca}^{++}$  release from the SR increases intracellular  $\text{Ca}^{++}$  which binds to **troponin C**, tropomyosin is moved out of the way, and interaction of actin and myosin occurs.
- 5. Relaxation** occurs when  $\text{Ca}^{++}$  is re-accumulated in SR by  **$\text{Ca}^{++}$  ATPase (SERCA, sarco-endoplasmic reticulum calcium-ATPase)**.

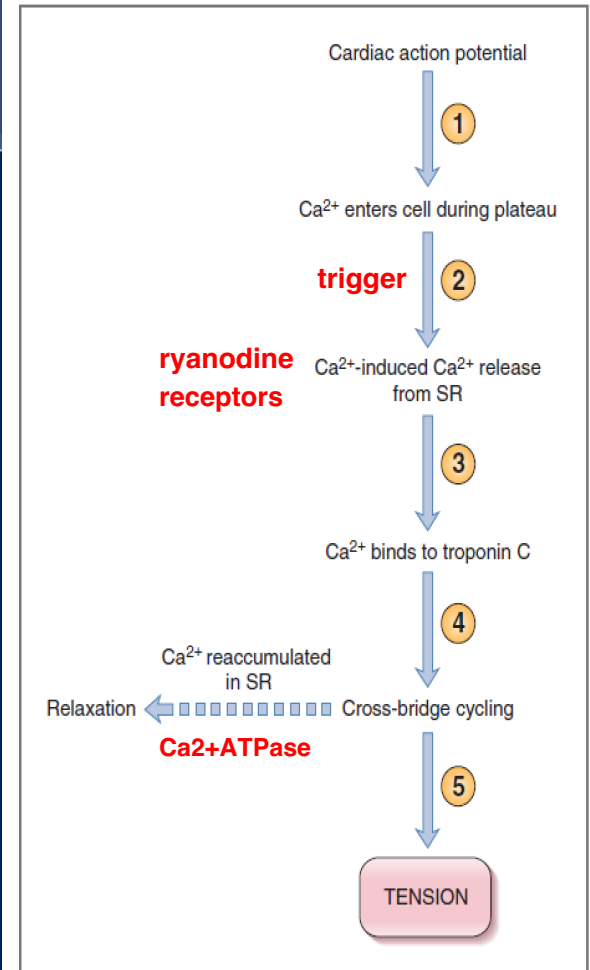

**Figure 4-18** Excitation-contraction coupling in myocardial cells. See the text for an explanation of the circled numbers. SR, Sarcoplasmic reticulum.



**CALCIUM IONS REGULATE THE CONTRACTION OF CARDIAC MUSCLE:**

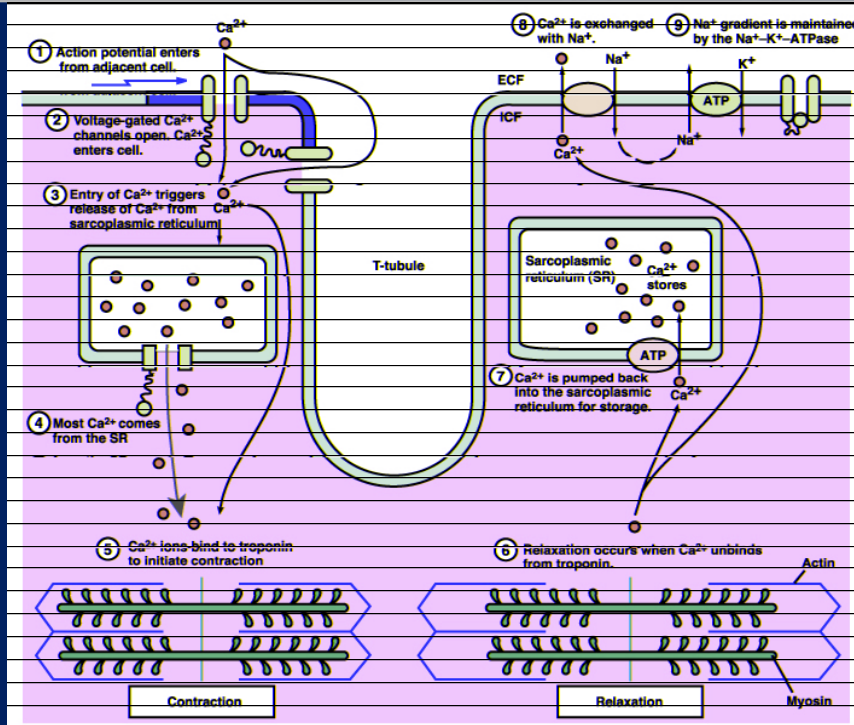

Entry of extracellular calcium ions causes the release of calcium from the sarcoplasmic reticulum (calcium-induced calcium release), source of about 95% of calcium in cytosol.

# Comparison of Role of Calcium In Bringing About Contraction in Smooth, Skeletal, and Cardiac Muscle

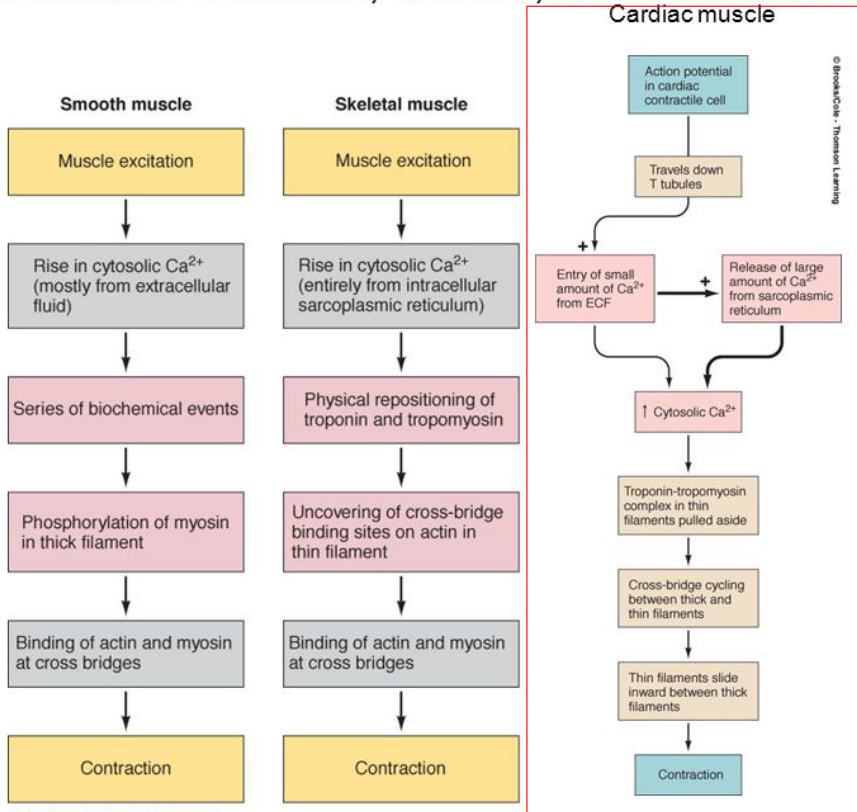

## EXCITATION-CONTRACTION COUPLING...

### What's the importance of $\text{Ca}^{+2}$ from T tubules?

- Without  $\text{Ca}^{+2}$  from T tubules, strength of cardiac muscle contraction would be reduced considerably because:
- the SR is less well developed than that of skeletal muscle and does not store enough  $\text{Ca}^{+2}$  to provide full contraction.
- Therefore, T tubules of cardiac muscle **have a diameter 5x as great as skeletal muscle tubules**
- Inside T tubules is a large quantity of mucopoly-saccharides that are electro-negatively charged and bind an abundant store of  $\text{Ca}^{+2}$  keeping  $\text{Ca}^{+2}$  available for diffusion to interior of cardiac muscle fiber when a T tubule AP appears.

## ILLUSTRATION OF THE INTERNAL STRUCTURES OF AN ADULT VENTRICULAR CARDIOMYOCYTE

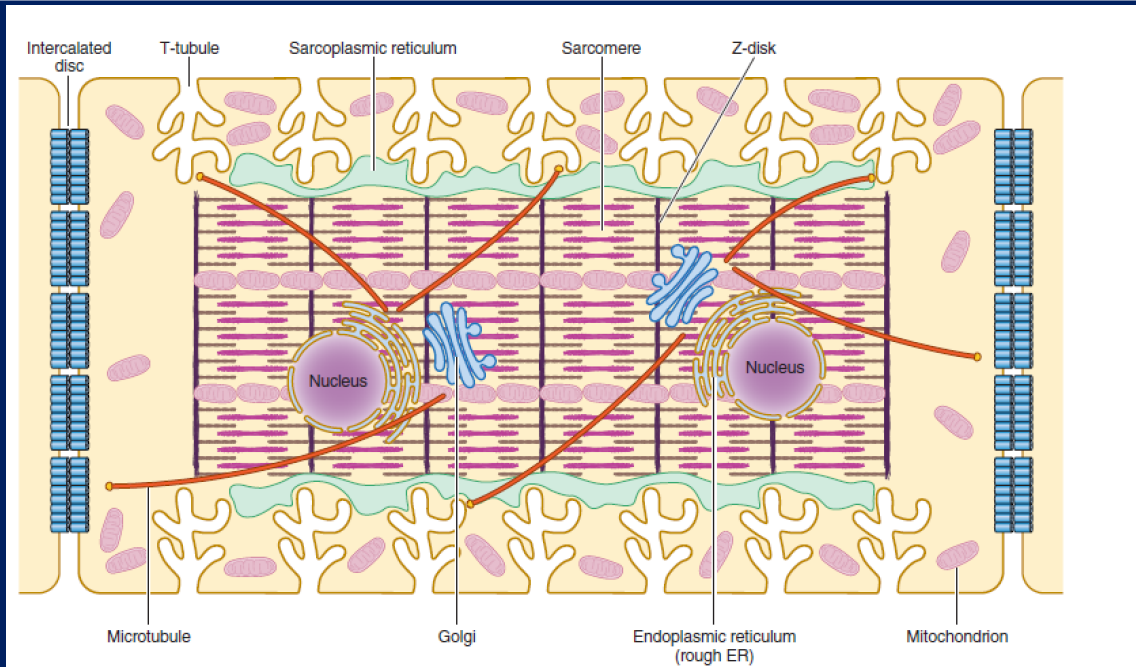

T-tubules, which are enriched with voltage-gated L-type calcium channels, are positioned closely near the sarcoplasmic reticulum, the primary internal calcium store.

## DURATION OF CONTRACTION

- Cardiac muscle begins to contract a few millisecond after AP begins and continues to contract until a few millisecond after AP ends.
- **The duration of contraction of cardiac muscle is mainly a function of the duration of AP** (about 0.2 sec in atrial muscle and 0.3 sec in ventricular muscle).

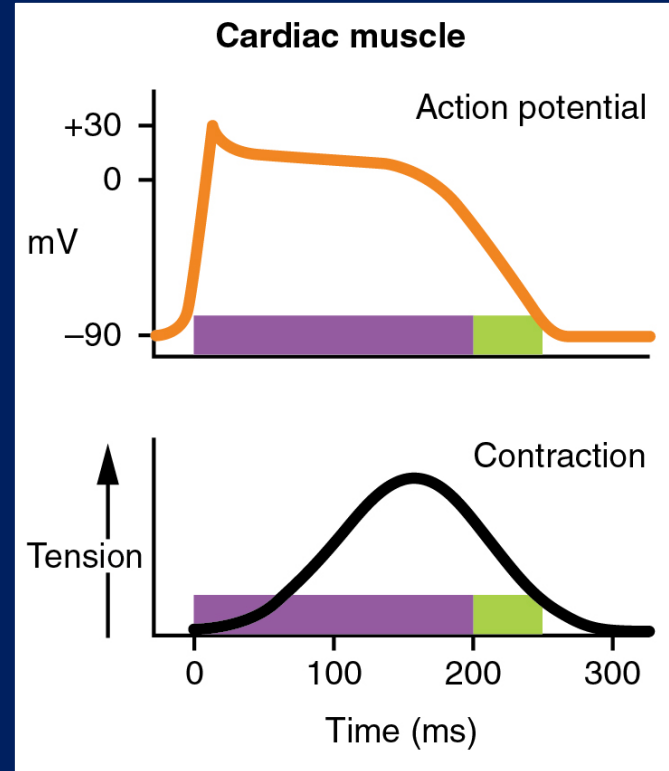

**FACTORS REGULATING  
CONTRACTILITY (INOTROPY)**

**Mechanisms for Changing Contractility**

- Contractility correlates directly with the **intracellular Ca<sup>2+</sup> concentration**
- Therefore, the larger the inward Ca<sup>2+</sup> current and the larger the intracellular stores, the greater the increase in intracellular Ca<sup>2+</sup> concentration and the greater the contractility.

## FACTORS REGULATING CONTRACTILITY

**Table 14.1** Effects of Autonomic Nerve Activity on the Heart

Region Affected	Sympathetic Nerve Effects	Parasympathetic Nerve Effects
SA node	Increased rate of diastolic depolarization; increased cardiac rate	Decreased rate of diastolic depolarization; decreased cardiac rate
AV node	Increased conduction rate	Decreased conduction rate
Atrial muscle	Increased strength of contraction	Decreased strength of contraction
Ventricular muscle	Increased strength of contraction	No significant effect



FEBRUARY 26, 2022

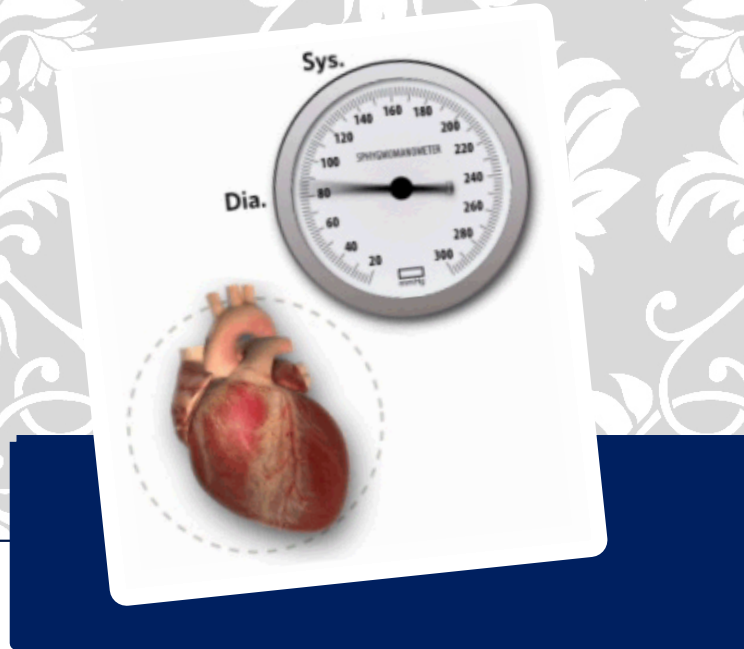

**Remember this lecture each time  
your heart beats**



## ABBREVIATIONS

AP: action potential

K<sup>+</sup> : potassium

Na<sup>+</sup>: Sodium

RP: refractory period

SR: sarcoplasmic reticulum