

# PHYSIOLOGY OF SYNAPSES AND RECEPTORS

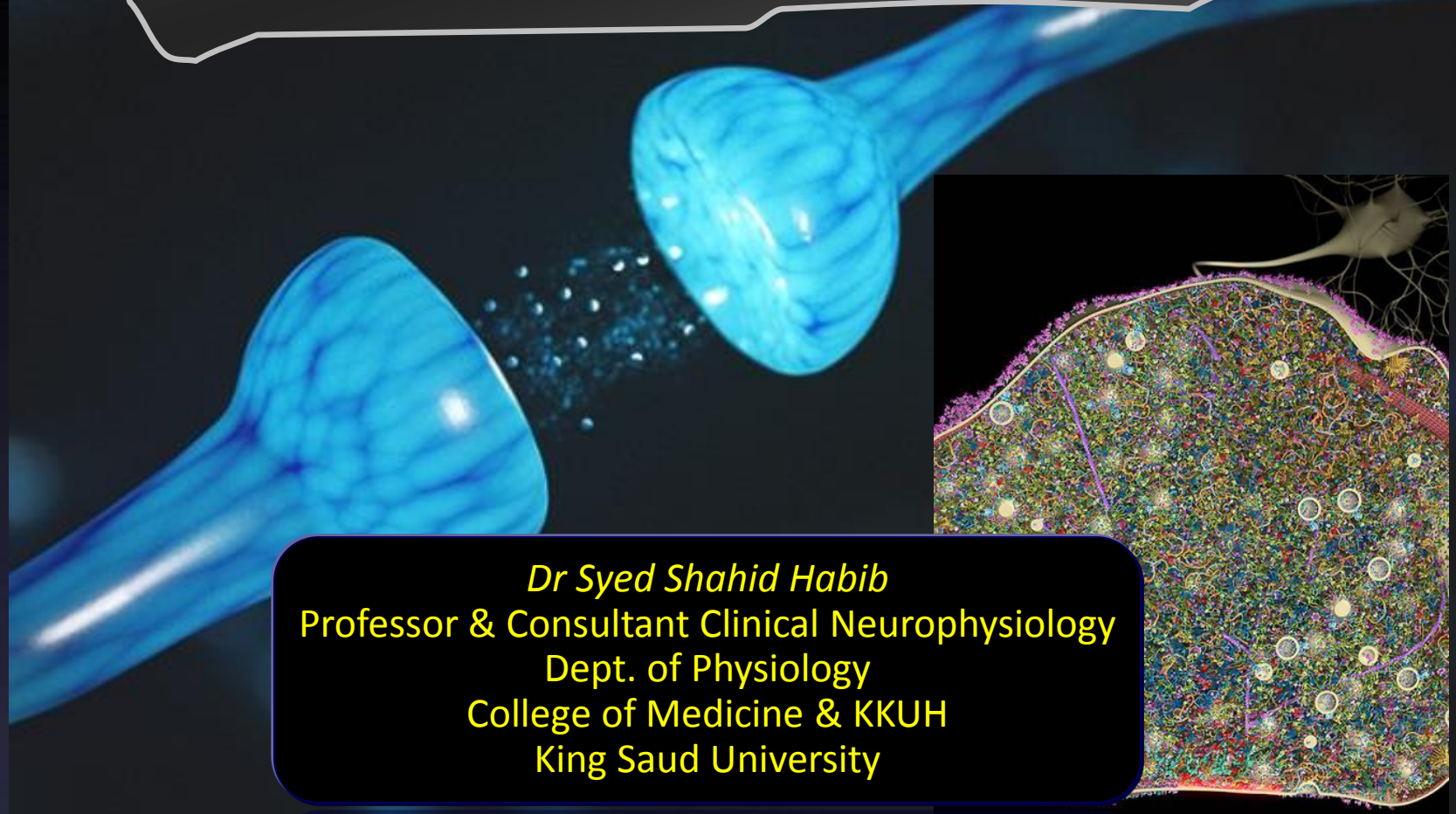

*Dr Syed Shahid Habib*  
Professor & Consultant Clinical Neurophysiology  
Dept. of Physiology  
College of Medicine & KCUH  
King Saud University

# OBJECTIVES

**At the end of this lecture the student should be able to :**

- Define synapses and enumerate functions of synapses.
- Classify types of synapses: anatomical & functional.
- Draw and label structure of synapses
- Describe Synaptic transmission & neurotransmitters
- Explain the fate of neurotransmitters.
- Explain electrical events at synapses (EPSPs & IPSPs).
- Elaborate Properties and Patterns of synaptic transmission in neuronal pools
- Explain factors affecting synaptic transmission

# HOW BRAIN FUNCTIONS?

- **Collection of sensory input**
- **Central Integration**
- **Motor output**

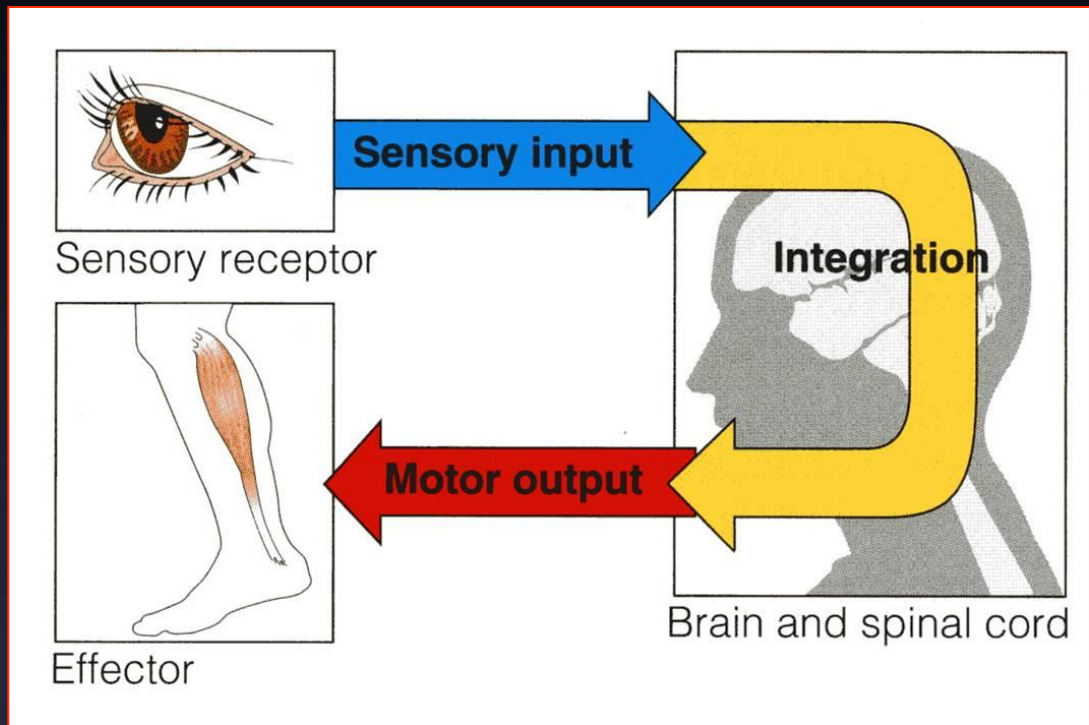

# The Synapse

## Synaptic Transmission/neurotransmitters

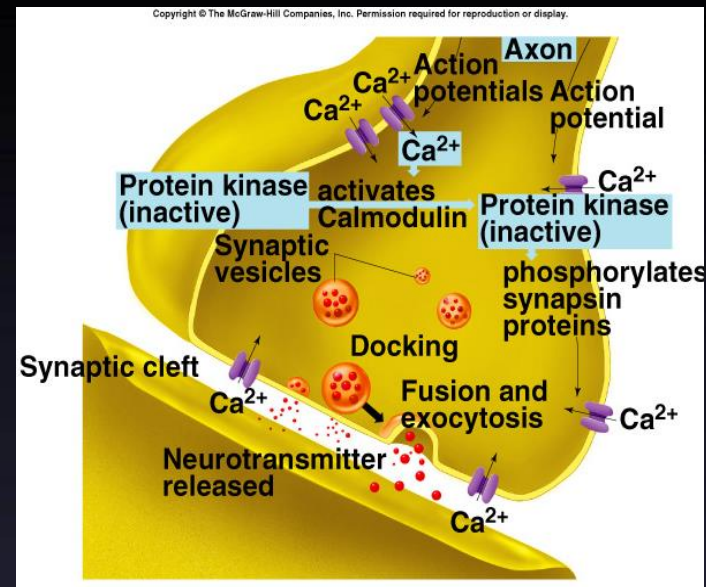
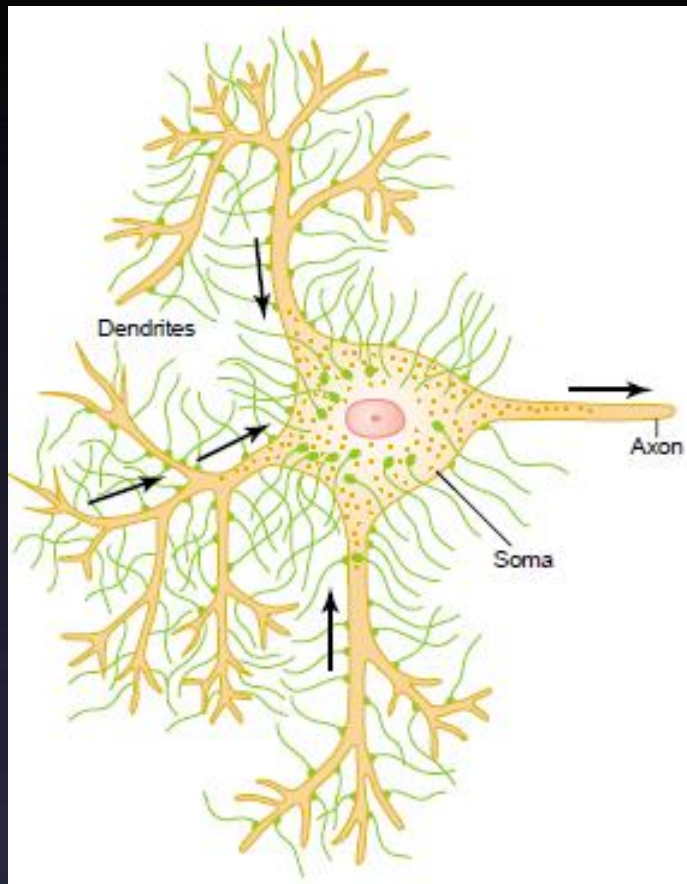

Information is transmitted in the central nervous system mainly in the form of nerve action potentials, called **NERVE IMPULSES**, through a succession of neurons, one after another.

# The Synapse

- A synapse is the connection between a neuron and a second cell.
- In the CNS, this other cell is also a neuron.
- In the PNS, the other cell may be either a neuron or an effector cell eg; gland or muscle



Sir John Eccles

A junction where the axon or some other portion of one cell (presynaptic cell) terminates on the dendrites, soma, or axon of another neuron (post synaptic cell).

"SYNAPTEIN",  
from the Greek "syn-" ("together") and "haptain" ("to clasp").



# Junctions outside the CNS

Neuromuscular junction

Contact between: autonomic neurons and smooth, cardiac muscles and any other effector cells.

The Neuromuscular Junction

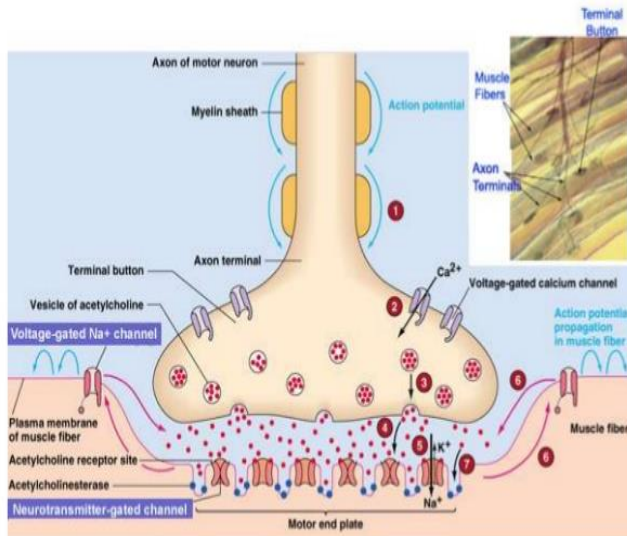

Autonomic Efferent Pathway

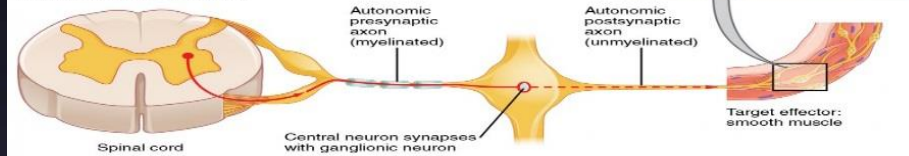

Somatic Efferent Pathway

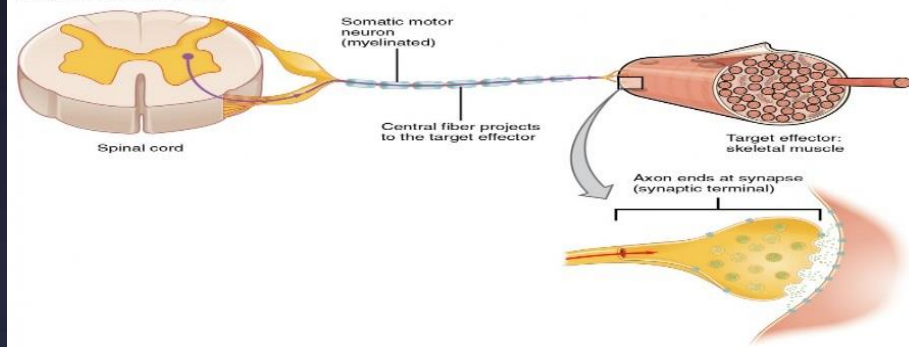

# Types of synapses

## Anatomical types

## Functional types

**Axodendritic**

**Axosomatic**

**Axoaxonic**

**Dendrodendritic**

**Dendrosomatic**

**Chemical synapses**

**Electrical synapses**

**Conjoint synapses**

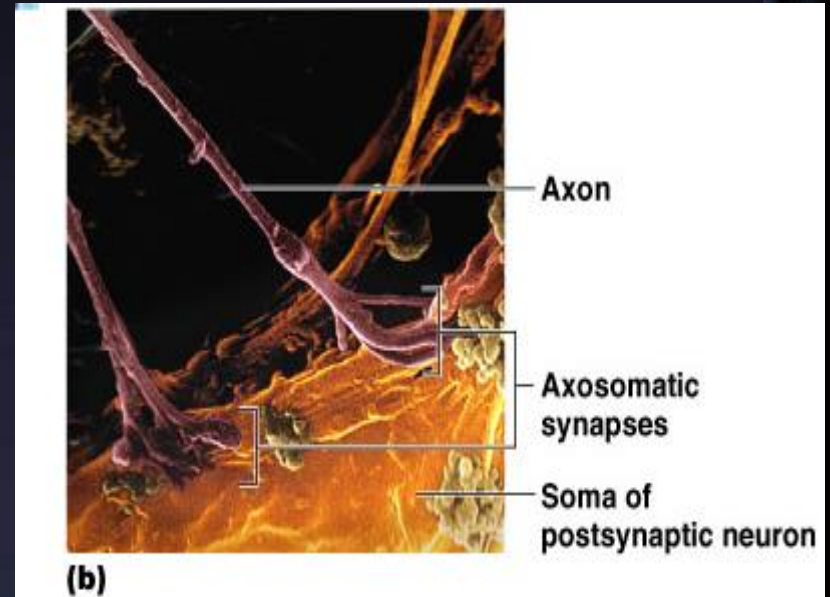
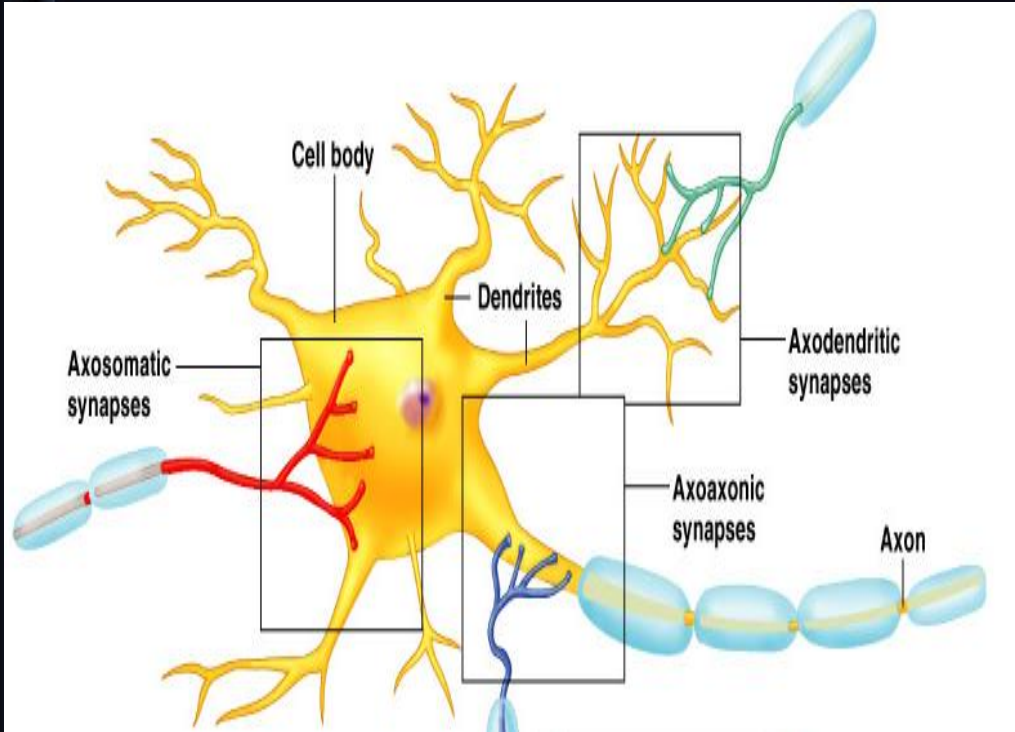

# Functional Types

## Chemical Synapse

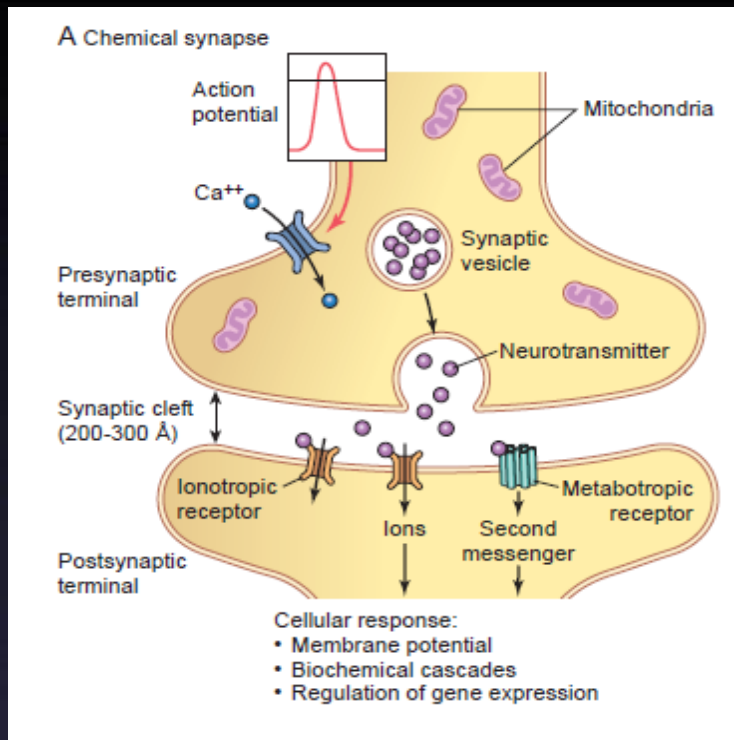

## Electrical Synapse

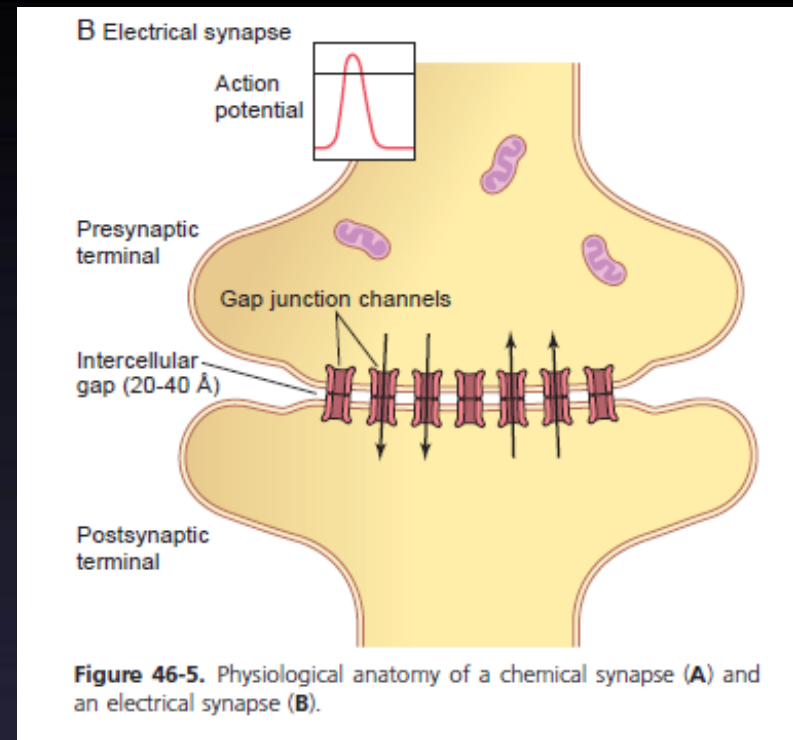

**Figure 46-5.** Physiological anatomy of a chemical synapse (A) and an electrical synapse (B).

**Conjoint synapse:** Both electrical and chemical.  
Examples → neurons in lateral vestibular nucleus.



# Electrical Synapse

- Impulses can be regenerated without interruption in adjacent cells.
- Gap junctions:
  - Adjacent cells electrically coupled through a channel.
  - Each gap junction is composed of 12 connexin proteins.

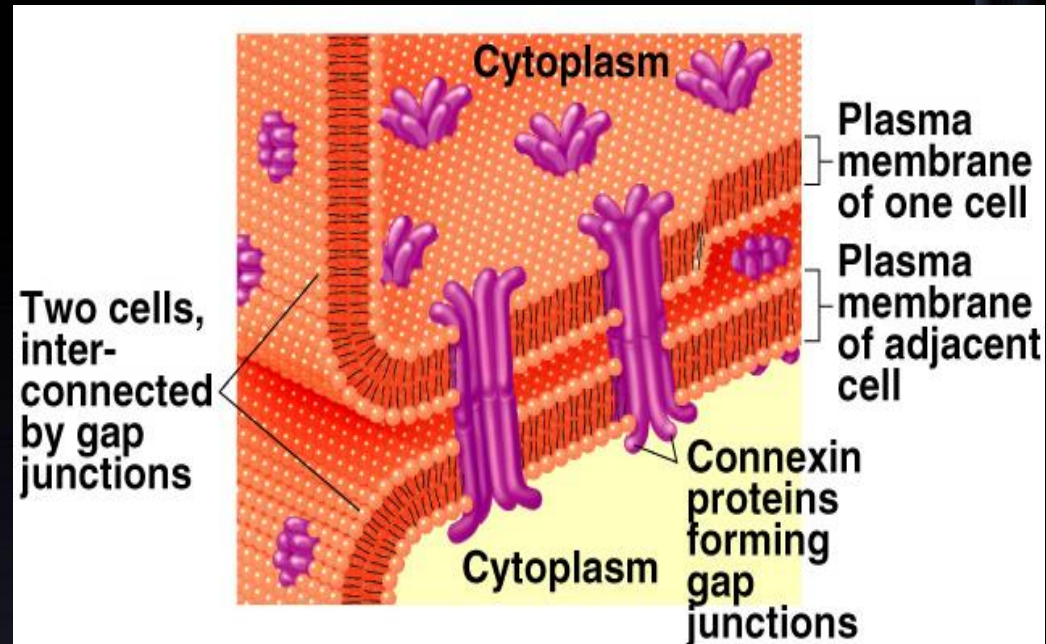

**Examples: Smooth and cardiac muscles, brain, and glial cells.**

Electrical synapses are present throughout the central nervous system

**The bidirectional transmission of electrical synapses permits them to help coordinate the activities of large groups of interconnected neurons. Promotes synchronous firing of a group of interconnected neurons.**

**For example, in**

Mental attention, Emotions and Memory  
Arousal from sleep

# Chemical Synapse

- Terminal bouton is separated from postsynaptic cell by synaptic cleft 20- to 40-nanometer
- NTs are released from synaptic vesicles.
- Vesicles fuse with axon membrane and NT released by exocytosis.
- Amount of NTs released depends upon frequency of AP.

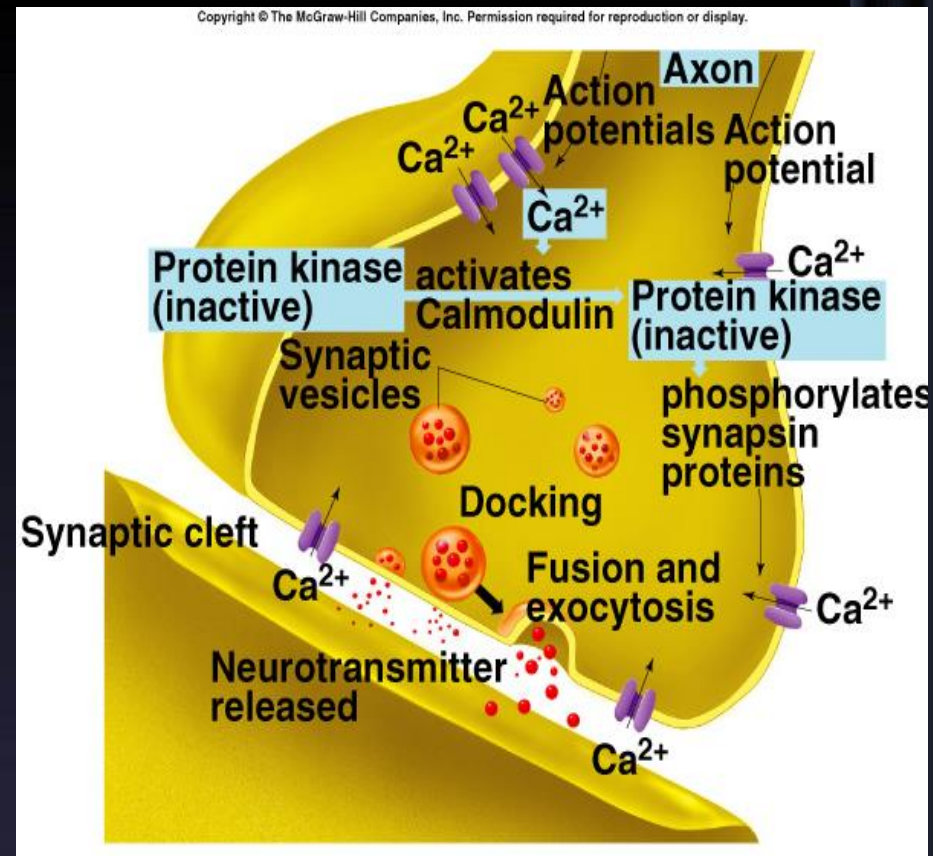

**“One-Way” Conduction at Chemical Synapses**

## A Chemical synapse

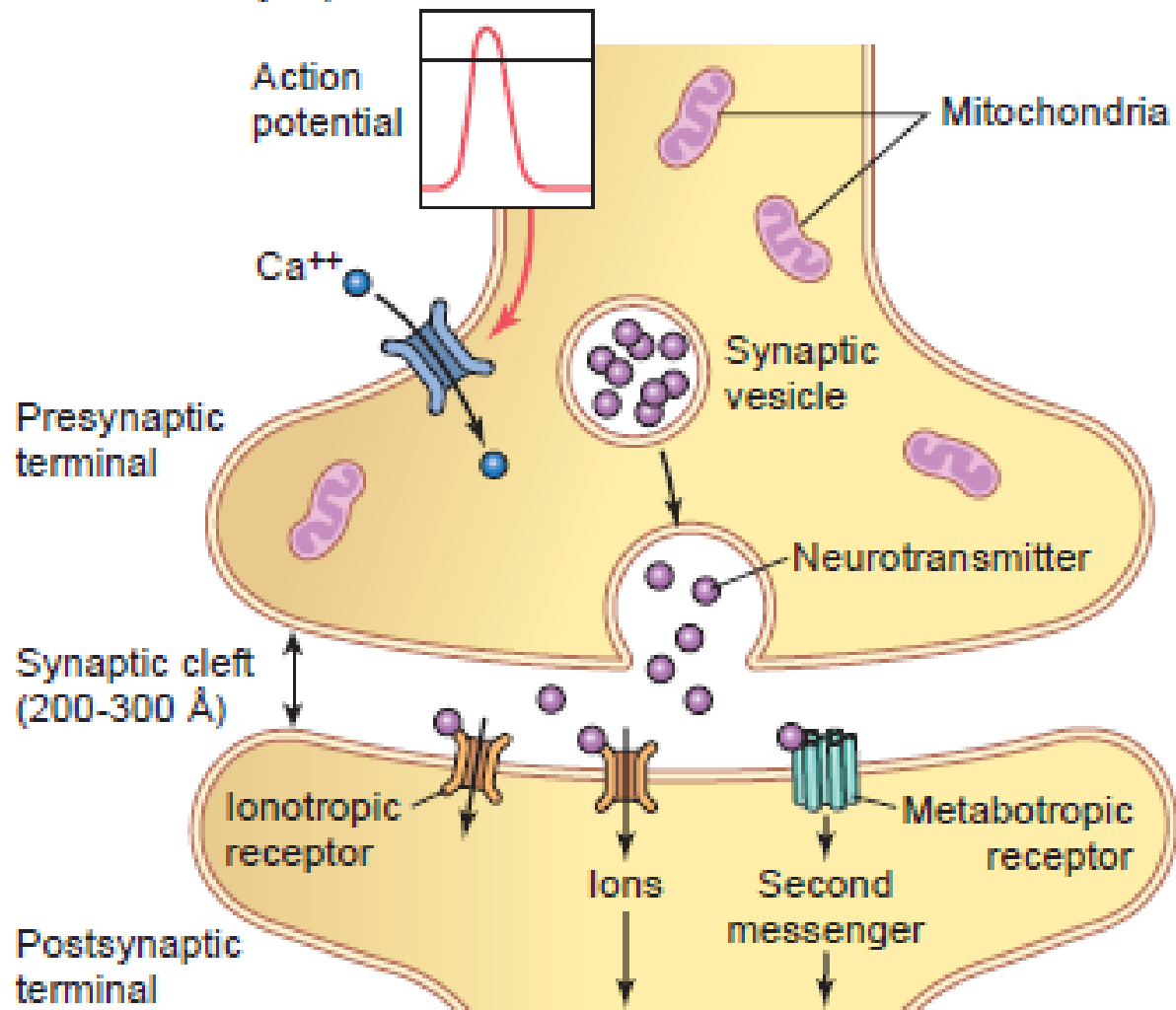

Cellular response:

- Membrane potential
- Biochemical cascades
- Regulation of gene expression

## B Electrical synapse

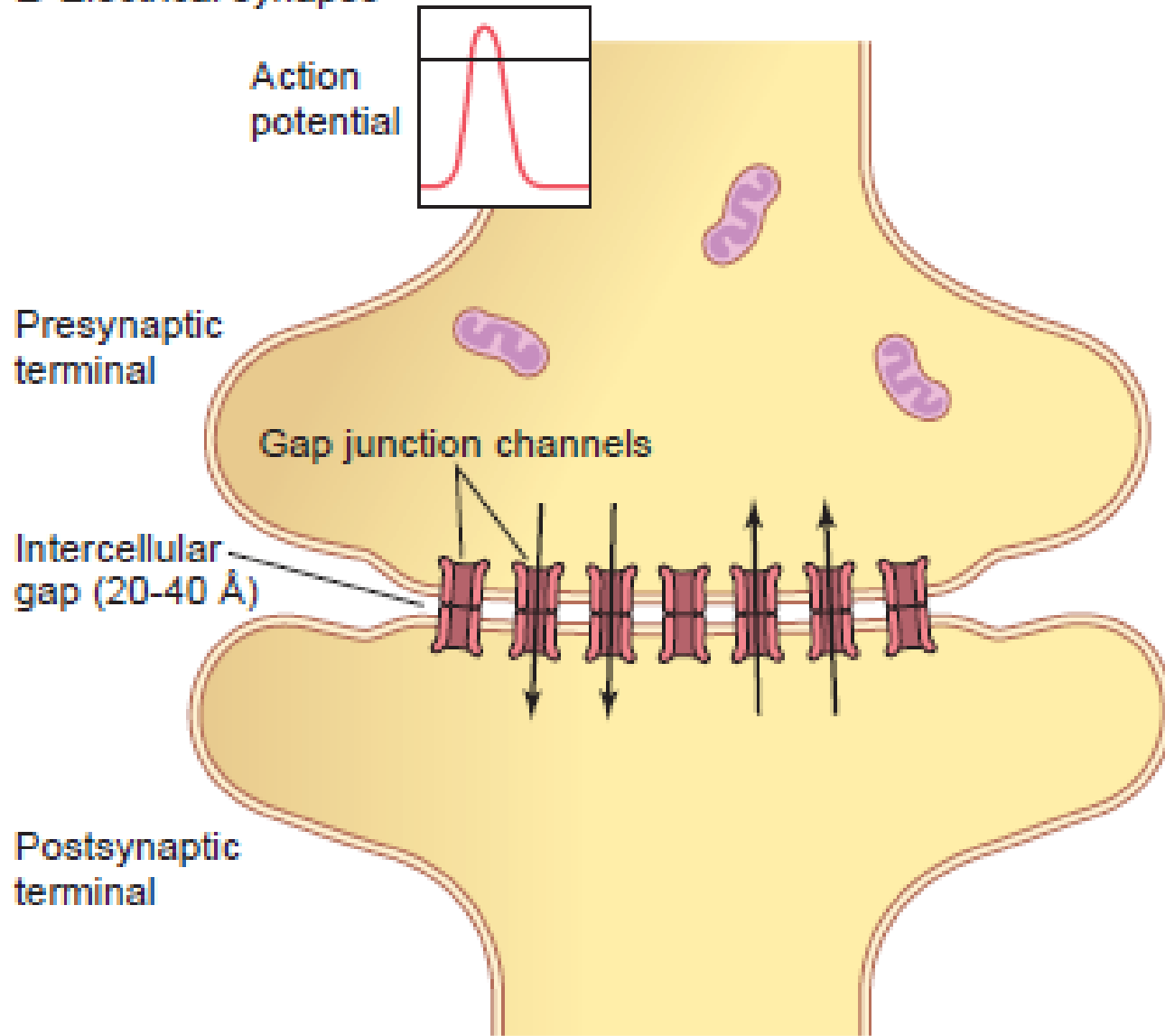

**Figure 46-5.** Physiological anatomy of a chemical synapse (A) and an electrical synapse (B).

# Synaptic Transmission (Events)

- NT release is rapid because many vesicles form fusion-complexes at “docking site.”
- AP travels down axon to bouton.
- VG  $\text{Ca}^{2+}$  channels open.
  - $\text{Ca}^{2+}$  enters bouton down concentration gradient.
  - Inward diffusion triggers rapid fusion of synaptic vesicles and release of NTs.
- $\text{Ca}^{2+}$  activates calmodulin, which activates protein kinase.
- Protein kinase aid in the fusion of synaptic vesicles.



# Synaptic Transmission (continued)

- NTs are released and diffuse across synaptic cleft.
- NT (ligand) binds to specific receptor proteins in postsynaptic cell membrane.
- NT effects are produced

## FATE OF NEUROTRANSMITTER

Diffusion out of synaptic cleft into surrounding fluid

Enzymatic destruction e.g. Ach esterase for Ach

Active transport back into pre-synaptic terminal itself  
e.g. norepinephrine

# Transmitter Substance acts on the Postsynaptic Neuron via “Receptor Proteins”

Have binding & intracellular component

**Receptor activation acts in one of two ways:**

(1) By gating ion channels directly and allowing passage of specified types of ions through the membrane  
**(ionotropic receptors)**

(2) By activating a “**second messenger**” that is not an ion channel but a molecule that protrudes into the cell cytoplasm and activates one or more substances inside the postsynaptic neuron  
**(metabotropic receptors)**

# “Second Messenger” System in the Postsynaptic Neuron acts in....

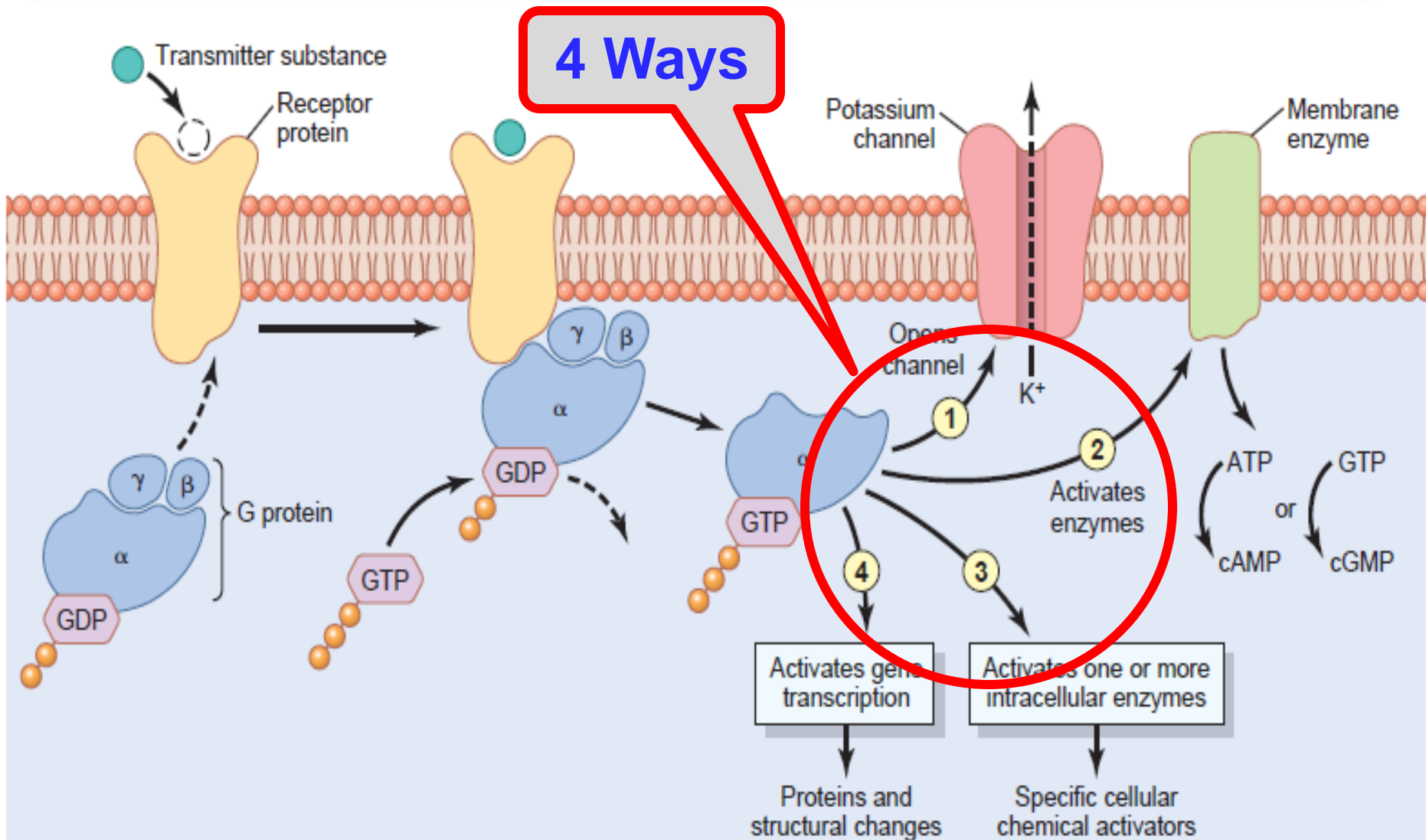

# EPSP & IPSP at Chemical Synapses

**EPSP** (excitatory postsynaptic potential):

1. Opening of Na channels to threshold level (Most Common).
2. ↓ conduction through Cl or K channels, or both.
3. Various changes in the internal metabolism of the postsynaptic neuron to excite or, in some instances, to ↑ excitatory membrane receptors or ↓ inhibitory membrane receptors.

**IPSP** (inhibitory postsynaptic potential):

1. Opening of Cl ion channels through the postsynaptic neuronal membrane.
2. ↑ in conductance of K ions out of the Neuron
3. Activation of receptor enzymes that inhibit cellular metabolic functions that ↑ inhibitory membrane receptors or ↓ excitatory membrane receptors.

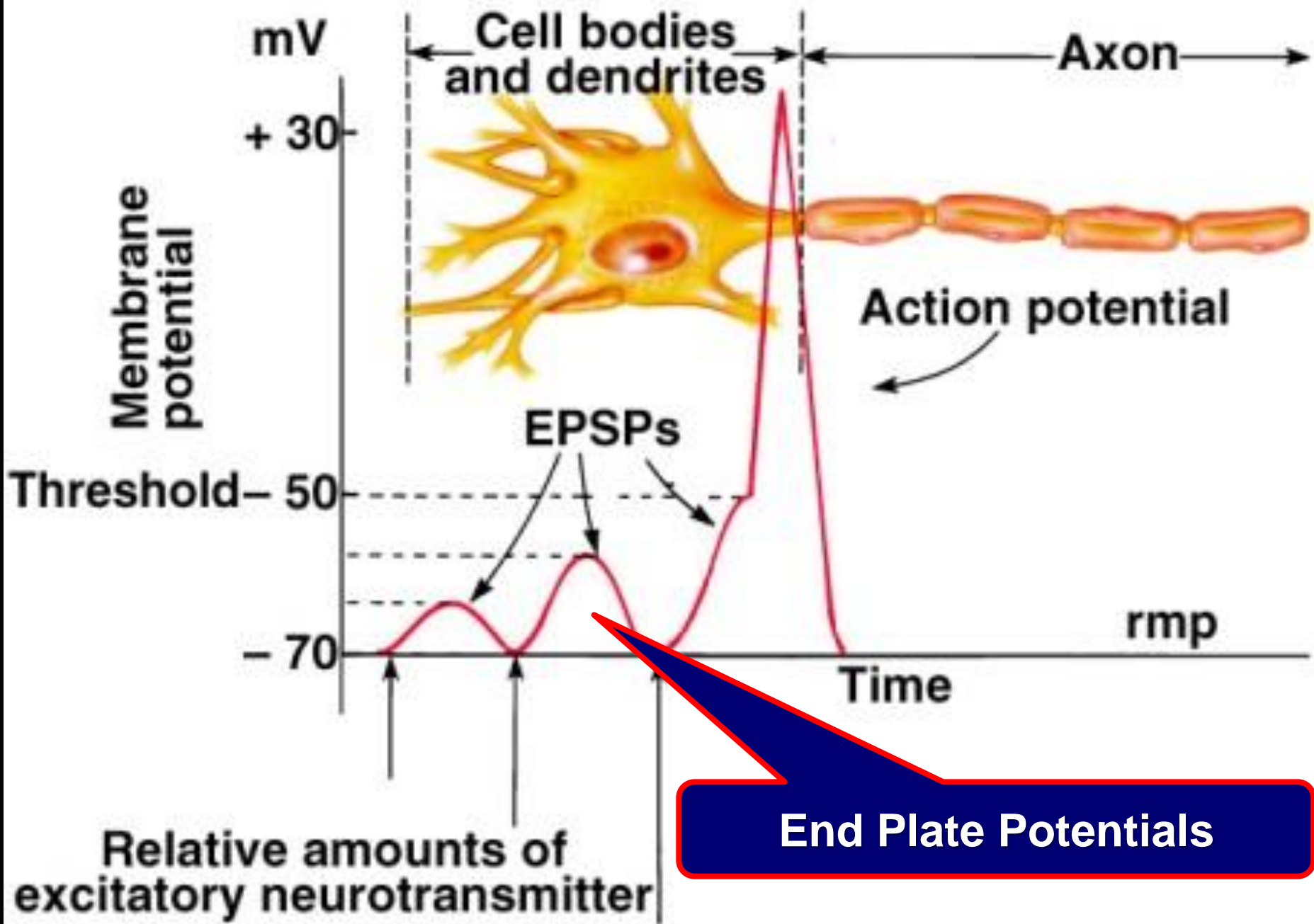



# Synaptic properties

- 1. One-way conduction:** Synapses generally permit conduction of impulses in one-way i.e. from pre-synaptic to post-synaptic neuron *“Bell- Magendie law”*..
- 2. Synaptic delay:** 0.5 ms for transmission across one synapse
- 3. Synaptic inhibition:** **4 Types:** Direct, Indirect, Reciprocal, Inhibitory interneuron
- 4. Summation:** Spatial & Temporal
- 5. Convergence and divergence:**
- 6. Fatigue (synaptic depression):**

## 2. Synaptic delay (Central Delay)

Is the minimum time required for transmission across the synapse. It is **0.5 ms** for transmission across one synapse.

This time is taken by.....

- Discharge of transmitter substance by pre-synaptic terminal
- Diffusion of transmitter to post-synaptic membrane
- Action of transmitter on its receptor
- Action of transmitter to ↑ membrane permeability
- Increased diffusion of Na<sup>+</sup> to ↑ post-synaptic potential

**Clinical Importance is that we can know number of synapses involved in neuronal pathways by time lag**

**A. Direct inhibition:** Occurs when an inhibitory neuron (releasing inhibitory substance) acts on a post-synaptic neuron leading to → hyperpolarization due to opening of  $\text{Cl}^-$  [IPSPs] and/or  $\text{K}^+$  channels. Example : **Glycine** at the level of the spinal cord to block pain impulses.

**B. Indirect Inhibition:** (Pre-synaptic inhibition): This happens when an inhibitory synaptic knob lie directly on the termination of a pre-synaptic excitatory fiber.  
The inhibitory synaptic knob inhibits the release of excitatory transmitter from the pre-synaptic fiber. e. g. **GABA** (**Pain modification**)

**C. Reciprocal inhibition:** Inhibition of antagonist muscle when agonist is excited.

**D. Inhibitory interneuron ( Renshaw cells):** Negative feedback inhibitory interneuron of a spinal motor neuron .

# PATTERNS OF SYNAPTIC TRANSMISSION IN NEURONAL POOLS

1-DIVERGENCE

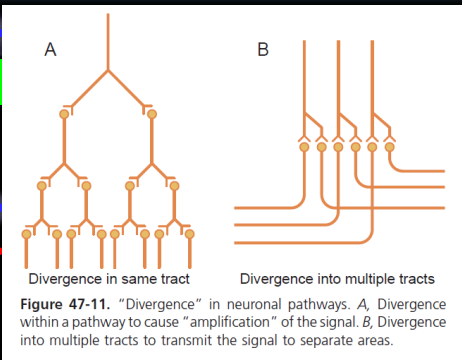

2-CONVERGENCE

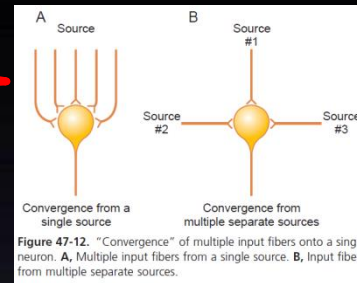

3-REVERBERATORY CIRCUIT

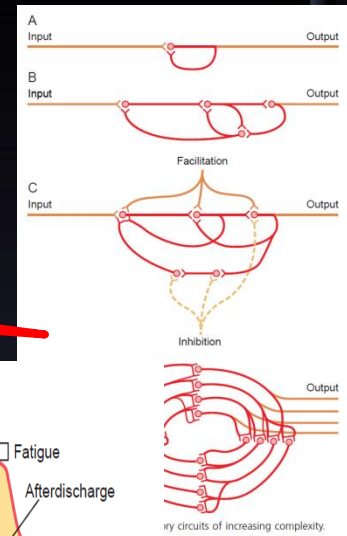

4-AFTER-DISCHARGE

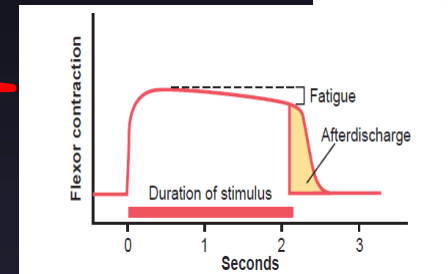

5-IRRADIATION

6-RECIPROCAL INHIBITION

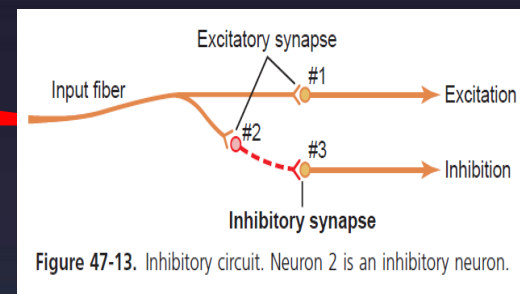

7-LOCAL SIGN

## **PATTERNS OF SYNAPTIC TRANSMISSION IN NEURONAL POOLS**

### **4-AFTER-DISCHARGE**

A prolonged maintained output discharge of AHCs called after-discharge, lasting a few milliseconds or many minutes after the incoming signal is over. Due to:

- 1- EPSP can continue to excite the neuron to transmit (a series of continuous repetitive discharges) .
- 2- Reverberating circuits: Presence of reverberating circuit restimulate AHCs

### **5- IRRADIATION**

Spread of impulses up & down to different segments and motor neurons in the spinal cord Ex; A strong stim in sensory afferent irradiate to many segments of S.C due to divergence

### **7- LOCAL SIGN**

The response to the stimulus by the body will be determined by the location of the stimulus on the body – i.e., a noxious stimulus to the hind limb does not result in withdrawal of a forelimb.



# 6-RECIPROCAL INHIBITION

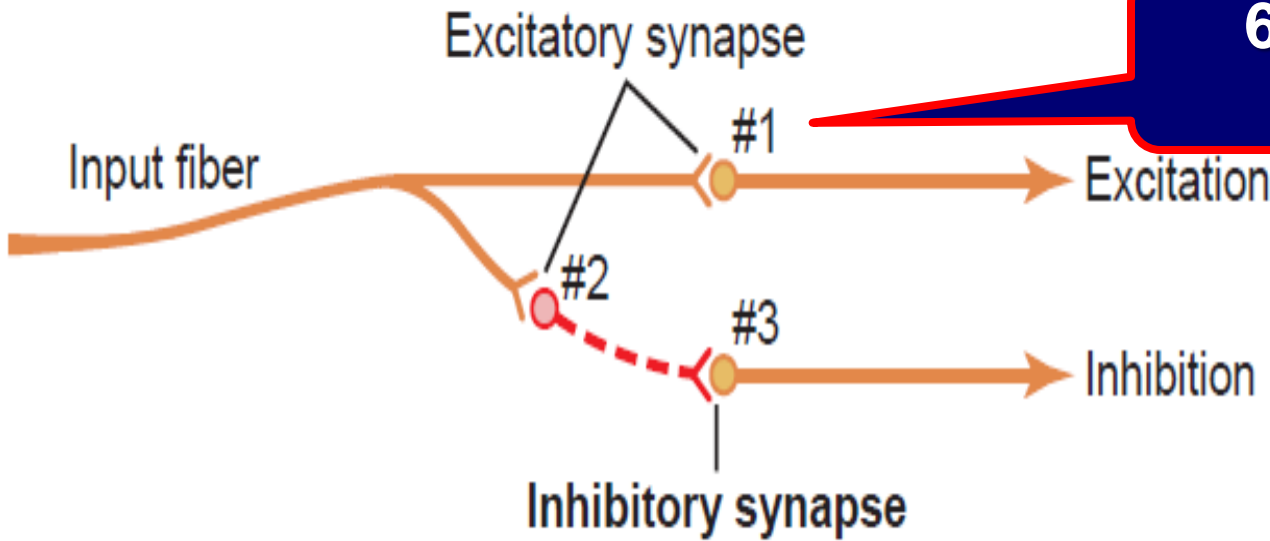

Pre-synaptic inhibition

Figure 47-13. Inhibitory circuit. Neuron 2 is an inhibitory neuron.

Neuronal Circuit With Both Excitatory and Inhibitory Output Signals

This type of circuit is characteristic for controlling all antagonistic pairs of muscles, and it is called the **reciprocal inhibition circuit.**

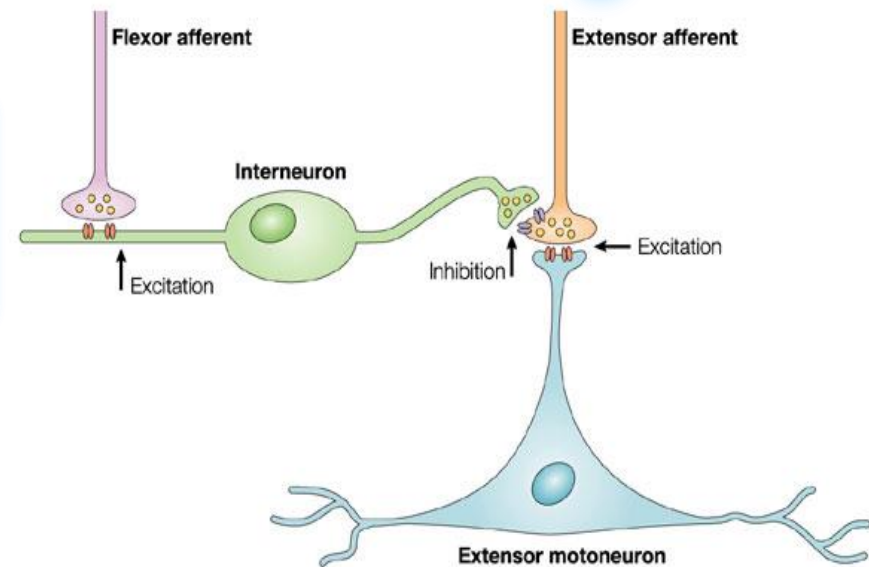

## D. Inhibitory interneuron (Renshaw cells)

**Negative feedback** inhibitory interneuron of a spinal motor neuron ;  
Send inhibitory cells that transmit inhibitory signals to the surrounding motor neurons → lateral inhibition → Sharpens Signals

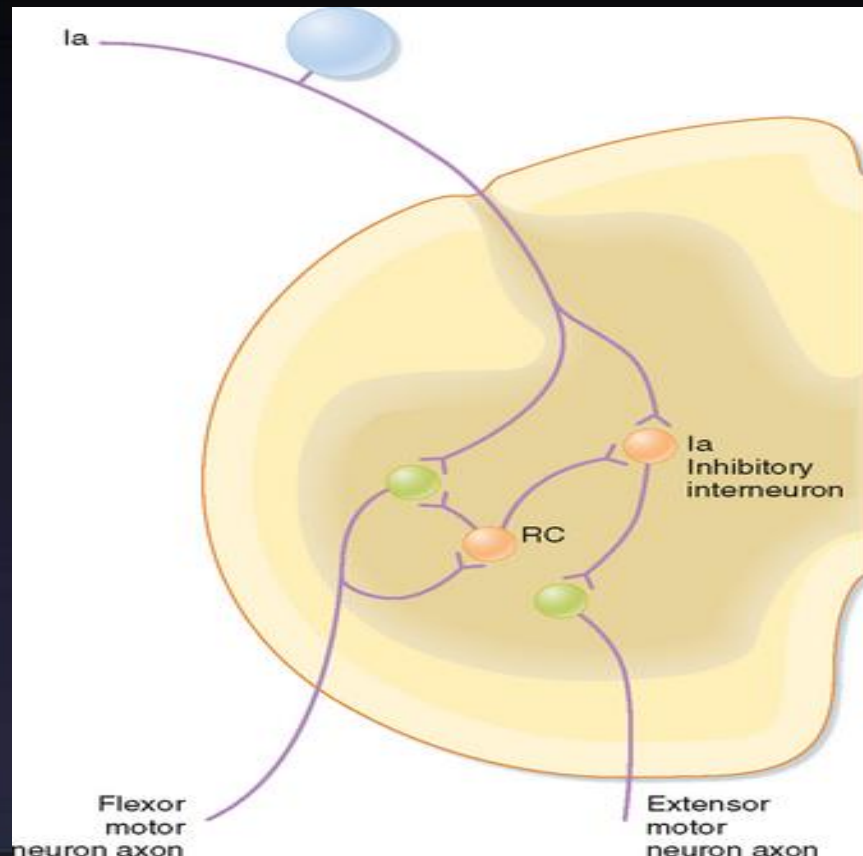

## C. Reciprocal inhibition:

Inhibition of antagonist muscle while agonist is excited.

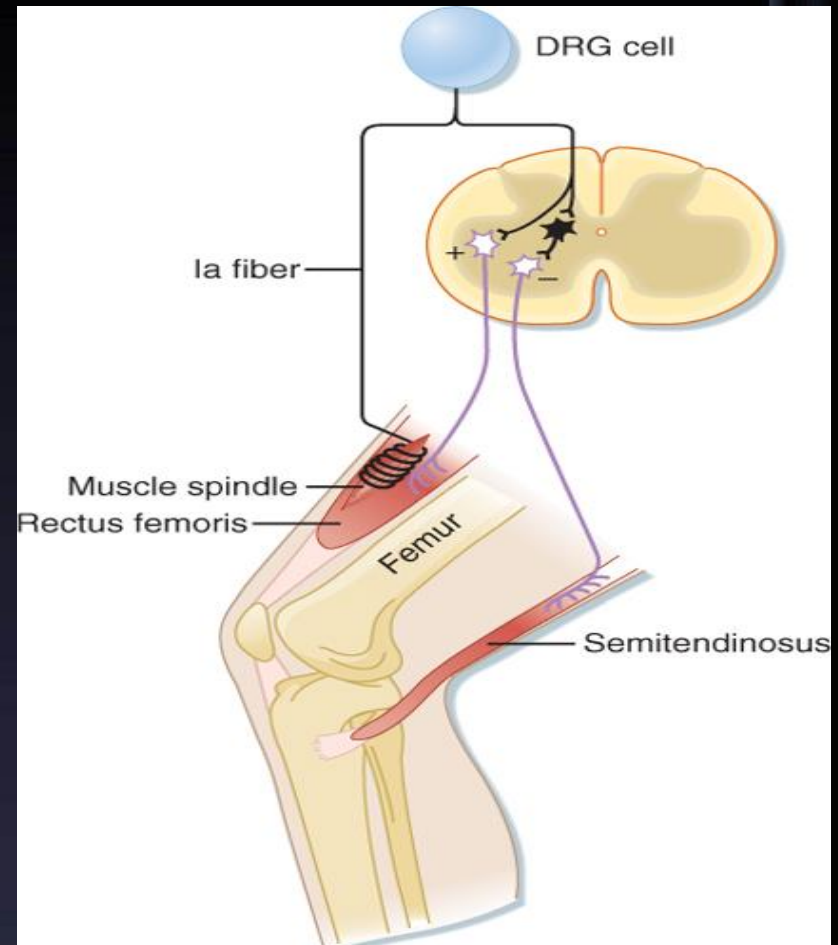

# Reverberatory (Oscillatory) Circuit

## Cause of Signal Prolongation.

- ❑ caused by positive feedback within the neuronal that re-excite the input of the same circuit.
- ❑ Once stimulated, the circuit may discharge repetitively for a long time called **long term potentiation**

The simplest Fig A, involves single neuron

Fig B shows additional neurons in the feedback circuit, which causes a longer delay between initial discharge and the feedback signal.

Fig C shows a more complex system in which both facilitatory and inhibitory fibers impinge on the reverberating circuit.

Fig D shows reverberating pathways with parallel fibers.

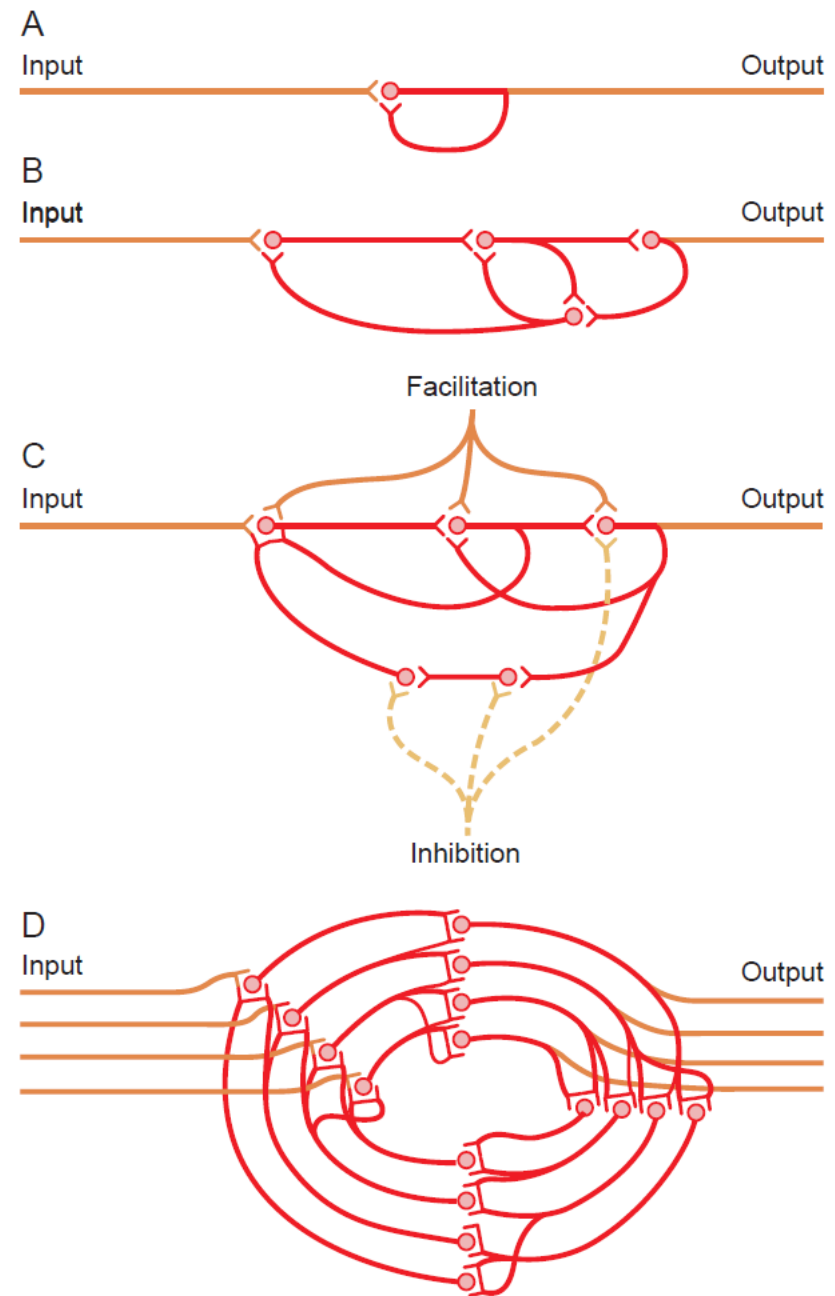

Figure 47-14. Reverberatory circuits of increasing complexity.

The cause of this sudden cessation of reverberation is fatigue of synaptic junctions in the circuit. Fatigue beyond a certain critical level lowers the stimulation of the next neuron in the circuit below threshold level so that the circuit feedback is suddenly broken.

## Synaptic fatigue

- Synaptic fatigue means simply that synaptic transmission becomes progressively weaker the more prolonged and more intense the period of excitation
- It is a short-term is an activity-dependent form of short term synaptic plasticity that results in the temporary inability of neurons to fire and therefore transmit an input signal (synaptic depression).

### Mechanism

- Exhaustion of the stores of transmitter
- inactivation of many of the postsynaptic membrane receptors
- Abnormal ion concentrations in postsynaptic neuron

Fatigue is a protective mechanism against excess neuronal activity. **Epilepsy!!**

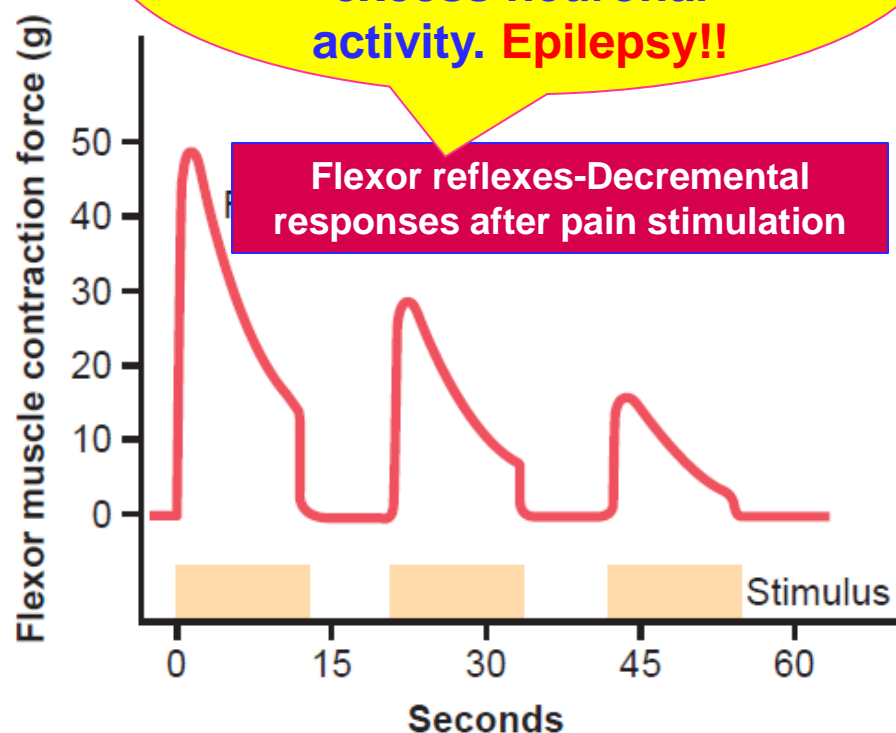

# TRANSMISSION OF SIGNALS OF DIFFERENT INTENSITY IN NERVE TRACTS BY SUMMATION

## Spatial Summation

Increasing signal strength is transmitted by using progressively greater numbers of fibers.

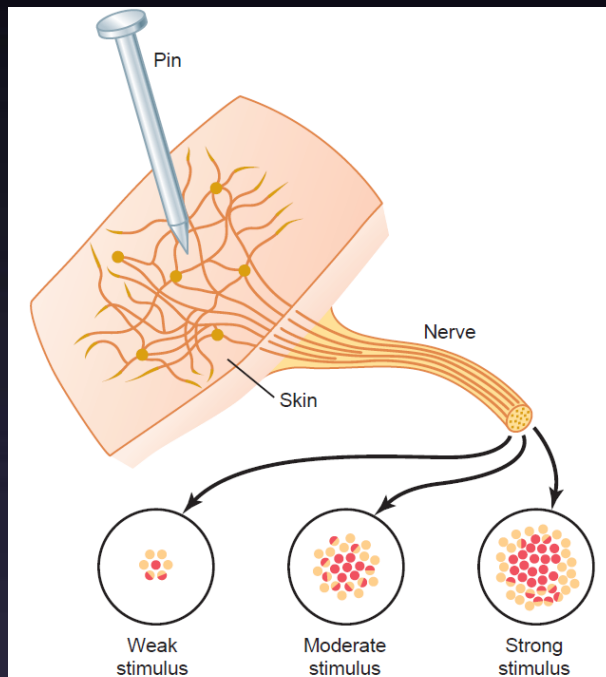
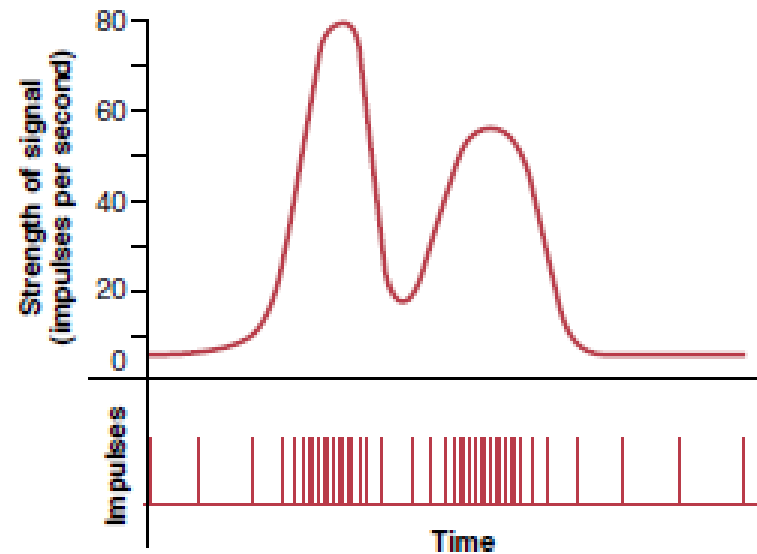

Figure 47-7. Pattern of stimulation of pain fibers in a nerve leading from an area of skin pricked by a pin. This pattern of stimulation is an example of *spatial summation*.

## Temporal Summation

Transmitting signals of increasing strength is by increasing the frequency of nerve impulses in each fiber



If EPSPs in a pre-synaptic knob are **successively** repeated without significant delay so the effect of the previous stimulus is summated to the next.



# In divergence weak signals entering a neuronal pool are amplified. Two major types

## Amplifying type

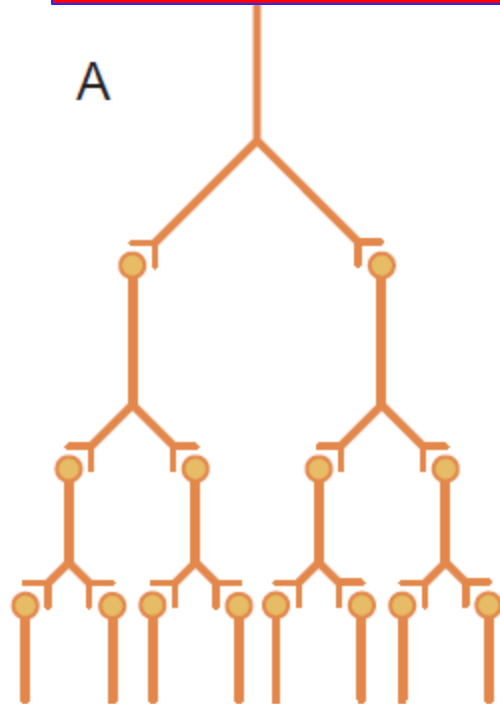

Divergence in same tract

## Divergence into multiple tracts

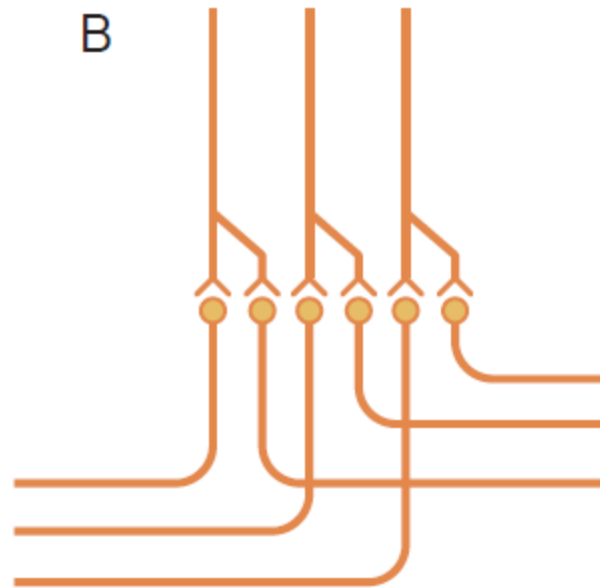

Divergence into multiple tracts

**Figure 47-11.** "Divergence" in neuronal pathways. *A*, Divergence within a pathway to cause "amplification" of the signal. *B*, Divergence into multiple tracts to transmit the signal to separate areas.

Eg; dorsal columns: of the spinal cord takes two courses in the lower part of the brain: (1) into the cerebellum and (2) on through the lower regions of the brain to the thalamus and cerebral cortex.

Eg; corticospinal pathway

**Convergence means signals from multiple inputs uniting to excite a single neuron**



**Action potentials converging on the neuron from multiple terminals provide enough spatial summation to bring the neuron to the threshold required for discharge.**

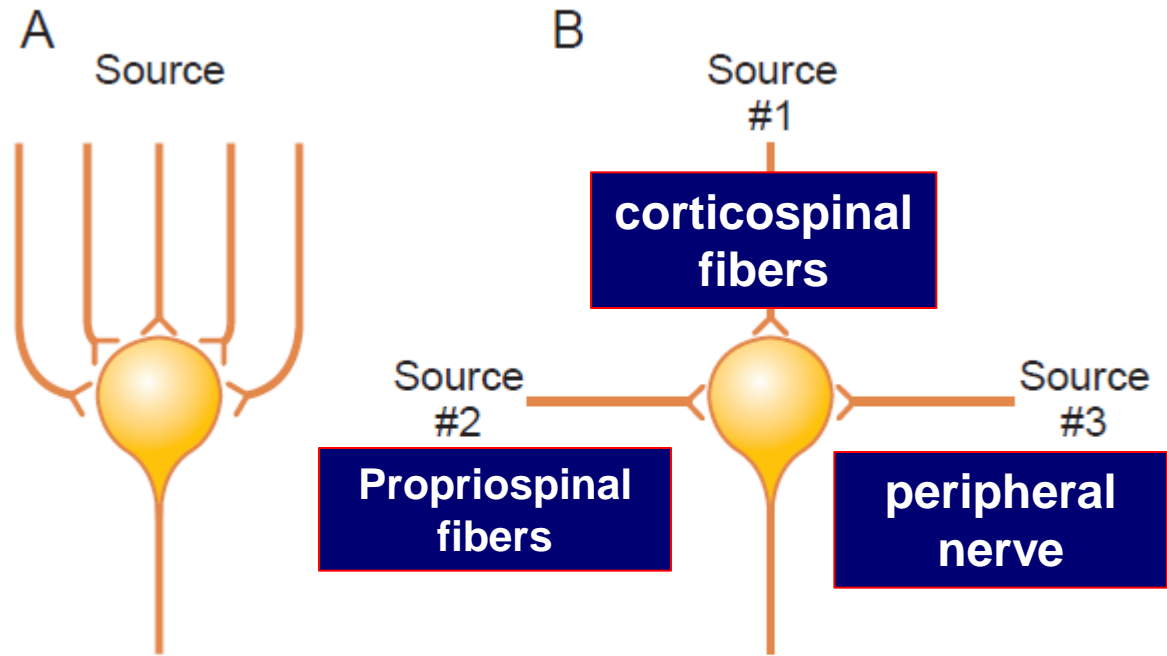

Convergence from a single source

Convergence from multiple separate sources

**Figure 47-12.** "Convergence" of multiple input fibers onto a single neuron. **A**, Multiple input fibers from a single source. **B**, Input fibers from multiple separate sources.

the interneurons of the spinal cord receive converging signals from

- (1) peripheral nerve fibers entering the cord,
- (2) Propriospinal fibers passing from one segment of the cord to another,
- (3) corticospinal fibers from the cerebral cortex, and
- (4) several other long pathways descending from the brain into the spinal cord.

**Convergence can also result from input signals (excitatory or inhibitory) from multiple sources**

# Factors affecting synaptic transmission

## Changes in internal environment:

- **Alkalosis:** ↑ neuronal excitability ; e.g. overbreating in epilepsy
- **Acidosis:** ↓ neuronal activity; e. g. diabetic or uremic acidosis coma
- **Hypoglycemia:** ↓ neuronal activity
- **Hypocalcemia:** ↑ neuronal excitability (tetany)
- **Hypoxia:** Depression of neurons

## Drugs:

- Caffeine depolarizes postsynaptic membrane
- Strychnine: competes with inhibitory transmitters
- Theophylline and theobromine increases neuronal excitability, by reducing the threshold for excitation of neurons.
- Sedatives, hypnotics & anesthetics: hyperpolarize (↑ threshold ) postsynaptic membrane.

## Diseases:

- Tetanus: Inhibits release of GABA (spastic)
- Botulism: Inhibits release of Ach (Flaccid)

## **Chemical Synapse**

## **Electrical Synapse**

**Exhibits synaptic delay eg at NMJ reveal a delay of 0.5 to 4.0 mili sec**

**Almost no delay in transmission.**

**20- to 40-nanometer distance that separates cells**

**Cells approach within about 3.8 nm of each other**

**Two separate cells that do not touch**

**Gap junctions are intercellular connection that directly connect the cytoplasm of cells**

**Slower than Electrical**

**Faster: many neurons fire synchronously**

**Mostly unidirectional**

**Mostly bidirectional**

**More complex behaviors**

**Are fast, but can produce only simple behaviors**

**Act on receptors which are specific**

**Without the need for receptors to recognize chemical messengers**

**The response may not be the same as the source.**

**The response is always the same sign as the source.**

**The response in the postsynaptic neuron is variable.**

**Lack Gain the signal in the postsynaptic neuron is the same or smaller than that of the originating neuron**

**THANKS**

