

Physiology of Vision

Lecture-1-

Physiology of the eye & Refraction

By

Dr /Salah Elmalik

College of Medicine

King Saud University

Learning Objectives

At the end of this lecture, the student should be able -:

- ❑ To Describe different components of the eye and function of each .
- ❑ Describe the refraction of light as it passes through the eye to the retina
- ❑ Identifying the refractive media of the eye
- ❑ Know fluid system of eye & glaucoma
- ❑ binocular vision .
- ❑ Know layers of retina, blind spot, and fovea
- ❑ Know principles of optics and errors of refraction

The Eye

- Human vision is one of the most complex visual systems among animals.
- The eye is a complex sensory organ, which capable of transduction physical stimuli of light rays into electrical and chemical signals that can be interpreted by the brain to construct physical images

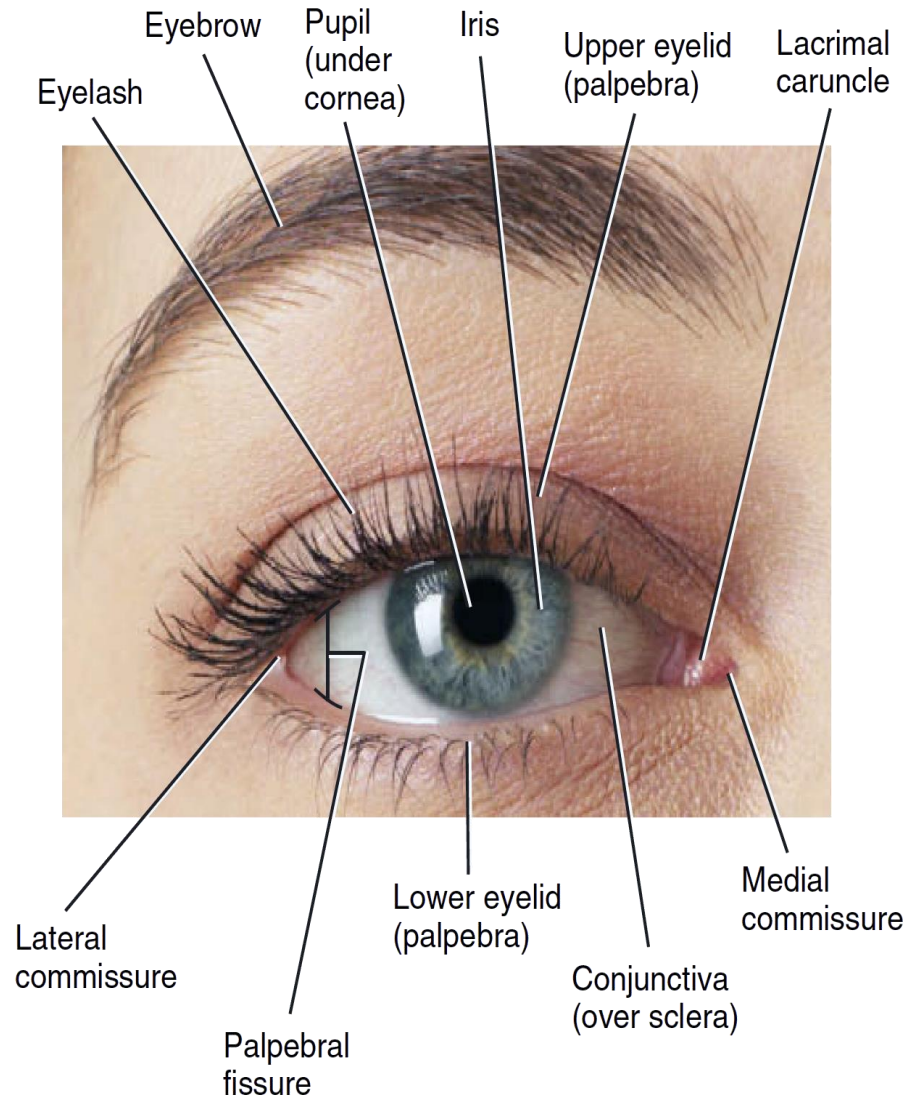

The eye consists of 3 layers :

1/ Outer fibrous layer

consists of :

- (a) Sclera
- (b) Cornea

- **Cornea** is transparent anterior portion
- **Conjunctiva** lines the eyelids and covers the sclera.
- It is a transparent epithelium covered with mucus and tear and prevent entrance of microbes and dust into the eye

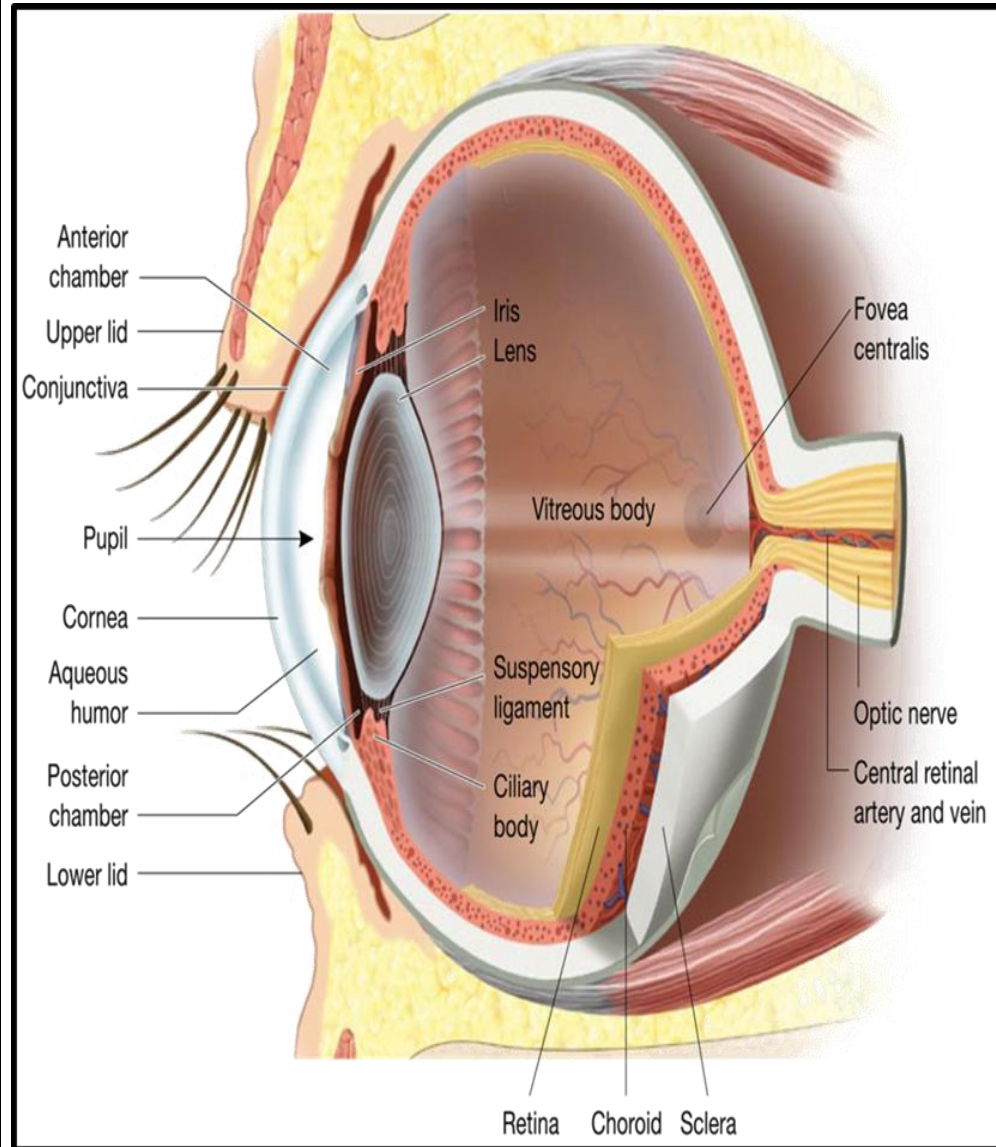

2. Middle Vascular Layer:

consists of :

(a) Iris:

- Is the colored part of the eye
- Has aperture (pupil) control & allow light to enter the eye

(b) Ciliary body:

Ciliary body consists of:

- Ciliary muscles
- Ciliary glands
- Suspensory ligaments which attached to the lens

(c) Choroid

- Is highly vascular structure
- The outermost layer of the retina depends mostly on diffusion from choroid blood vessels for nutrition specially oxygen supplying

Uvea = choroid + iris + ciliary body

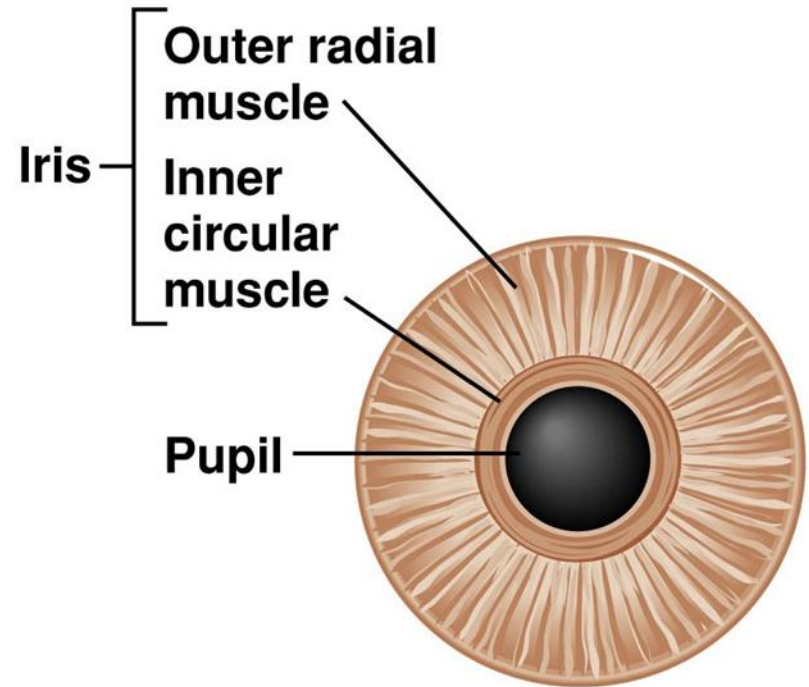

(a) Anatomy of iris and pupil

Copyright © 2008 Pearson Education, Inc., publishing as Benjamin Cummings

The Pupillary Muscles: consists of → Radial and Circular parts

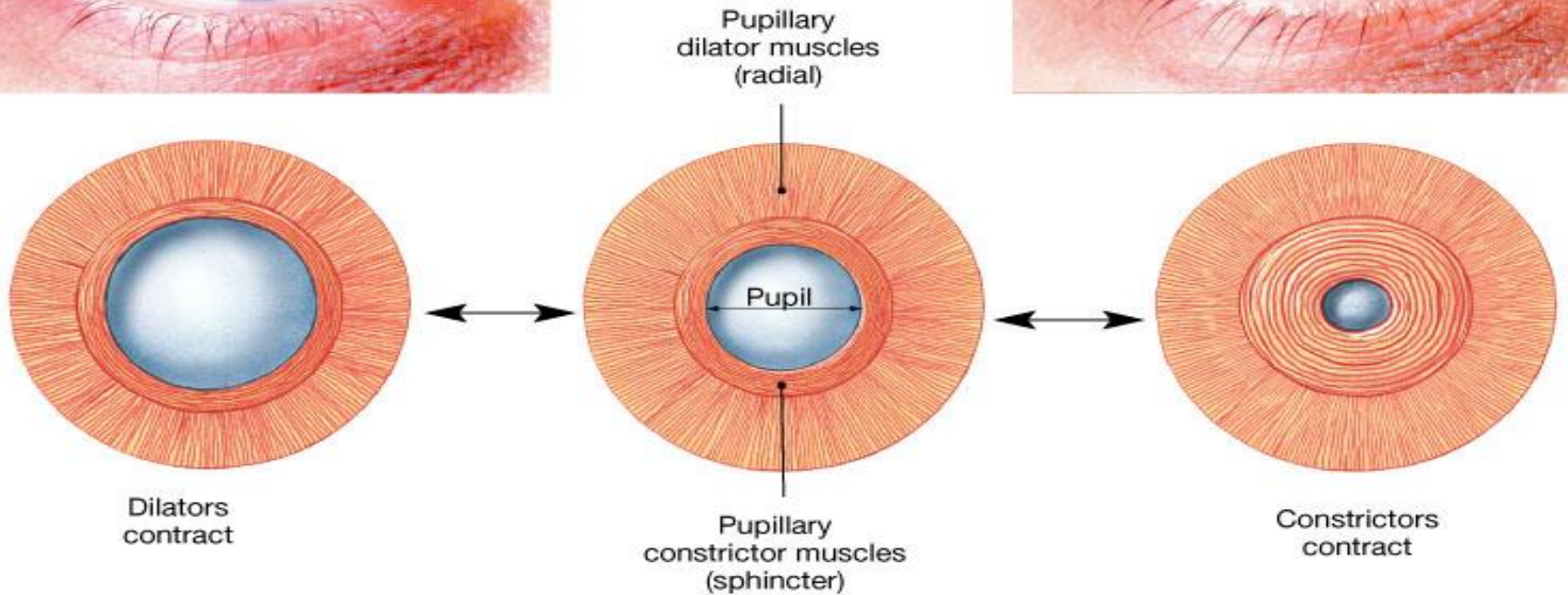
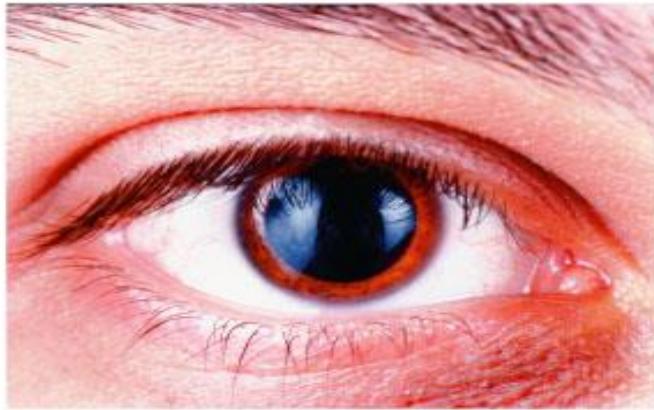
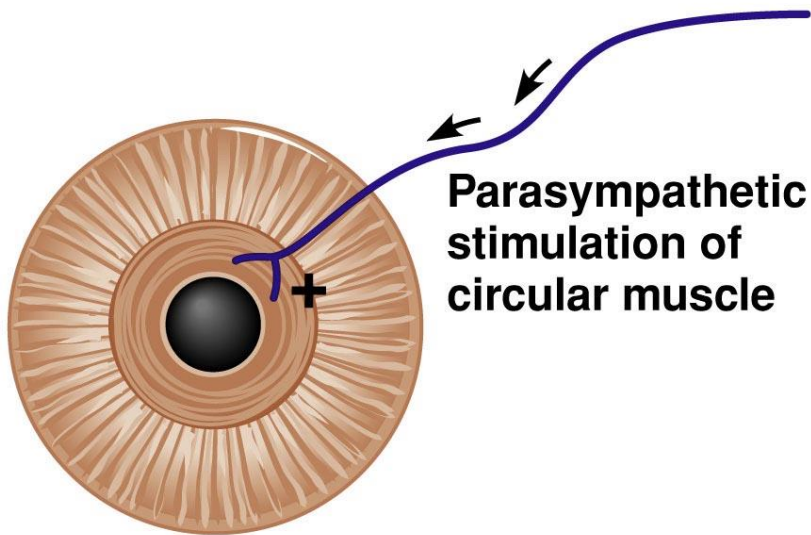
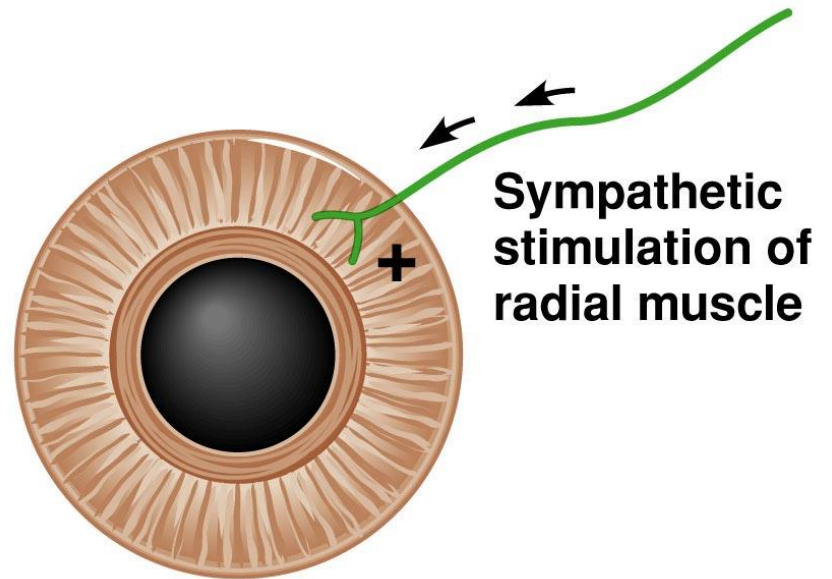

Figure 17.5



(b) Pupillary constriction

Copyright © 2008 Pearson Education, Inc., publishing as Benjamin Cummings



(c) Pupillary dilation

Copyright © 2008 Pearson Education, Inc., publishing as Benjamin Cummings

The Anterior & Posterior Cavities

- The Ciliary Body (& its suspensory ligament) and lens divide the eye into :
- (1) Anterior cavity which contains a fluid called Aqueous Humor
- (2) Posterior cavity (which contains fluid called Vitreous Humor)

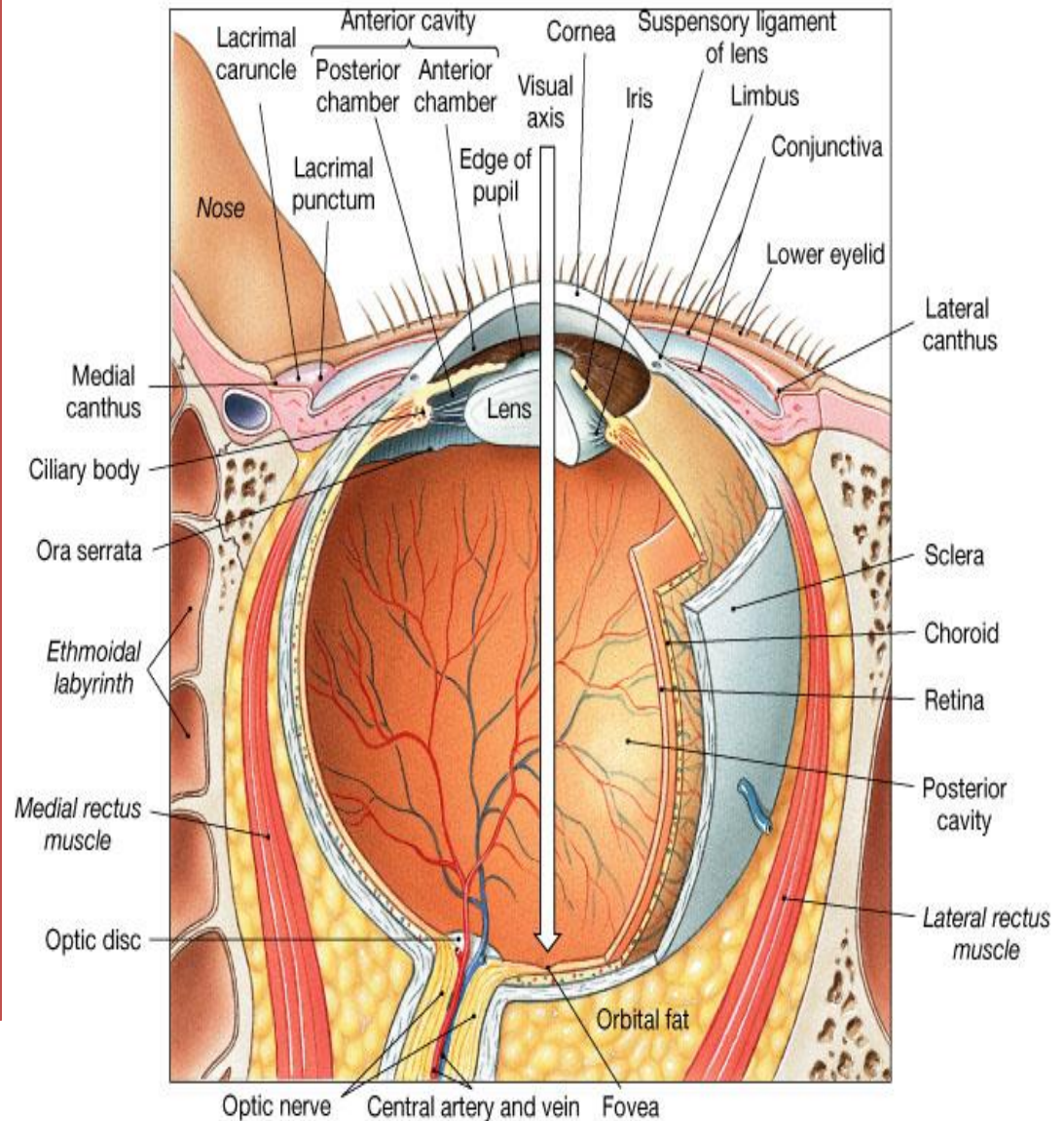

(c) Horizontal section

The Anterior and Posterior Chambers

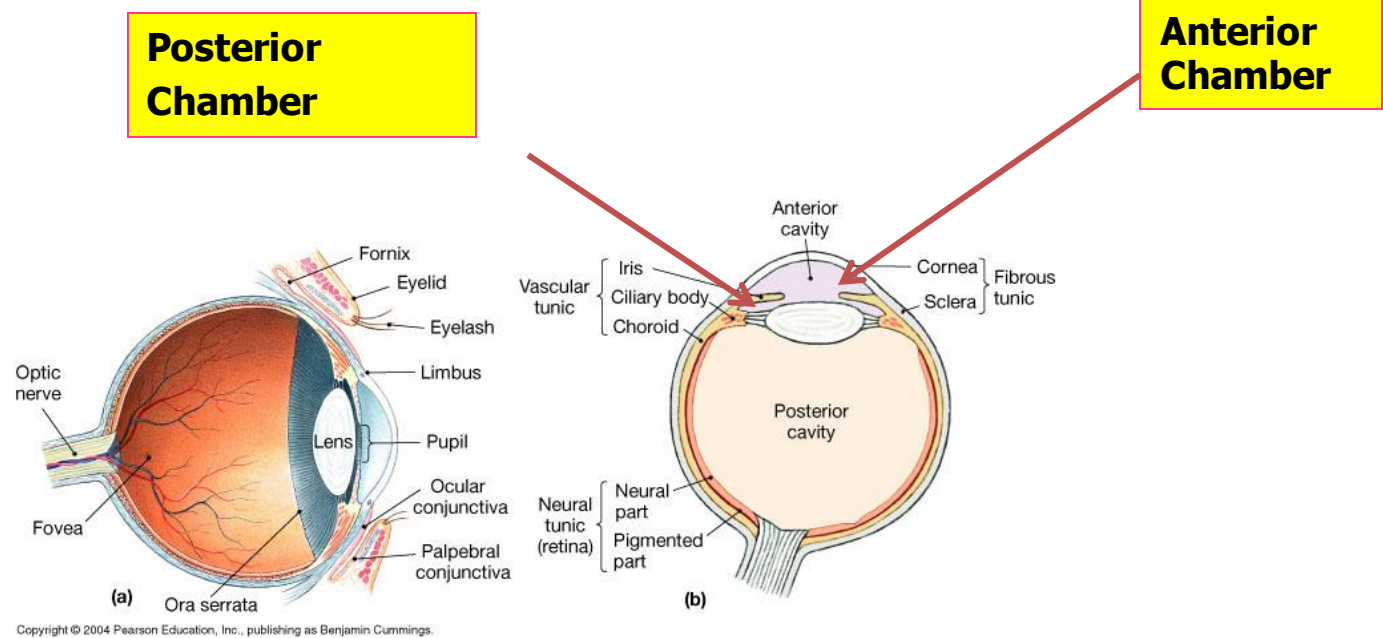

- Furthermore, the **iris** further divides the anterior cavity into :
(a) **Anterior Chamber** (in front of the iris) , and
(b) **Posterior Chamber** (behind the iris ; between the iris and lens) .

3. The Retina:

consists of :

- Outer pigmented portion (part)
- Inner neural part , containing Photoreceptors called Rods and **Cones** .

Pigment epithelium
Rod and cone
Outer segments
Inner segments
Outer nuclear layer
Outer plexiform layer
Inner nuclear layer
Inner plexiform layer
Ganglion cell layer
Optic nerve fibers

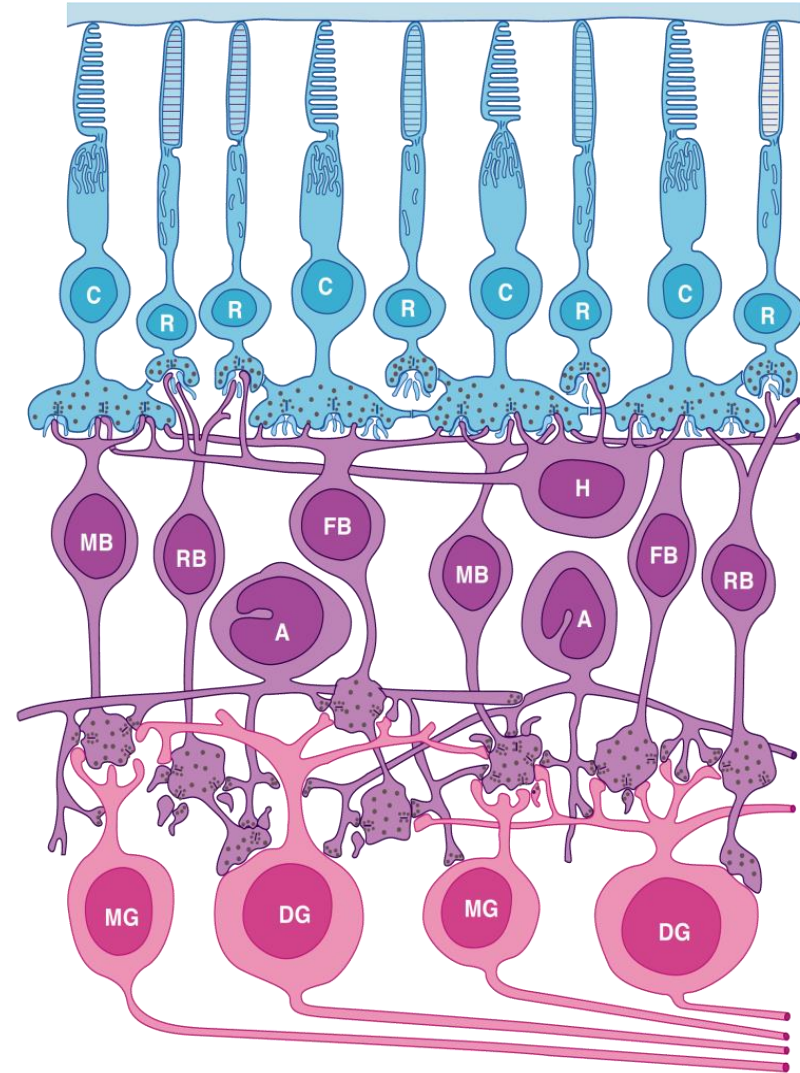

Rods & Cones

Rods

- are best for vision in dim light (scotopic vision)

Cones

- are best for
- vision in daylight or bright light (**photopic vision**)
 - Color Vision (color perception)
 - Perception of detail (acuity of vision)

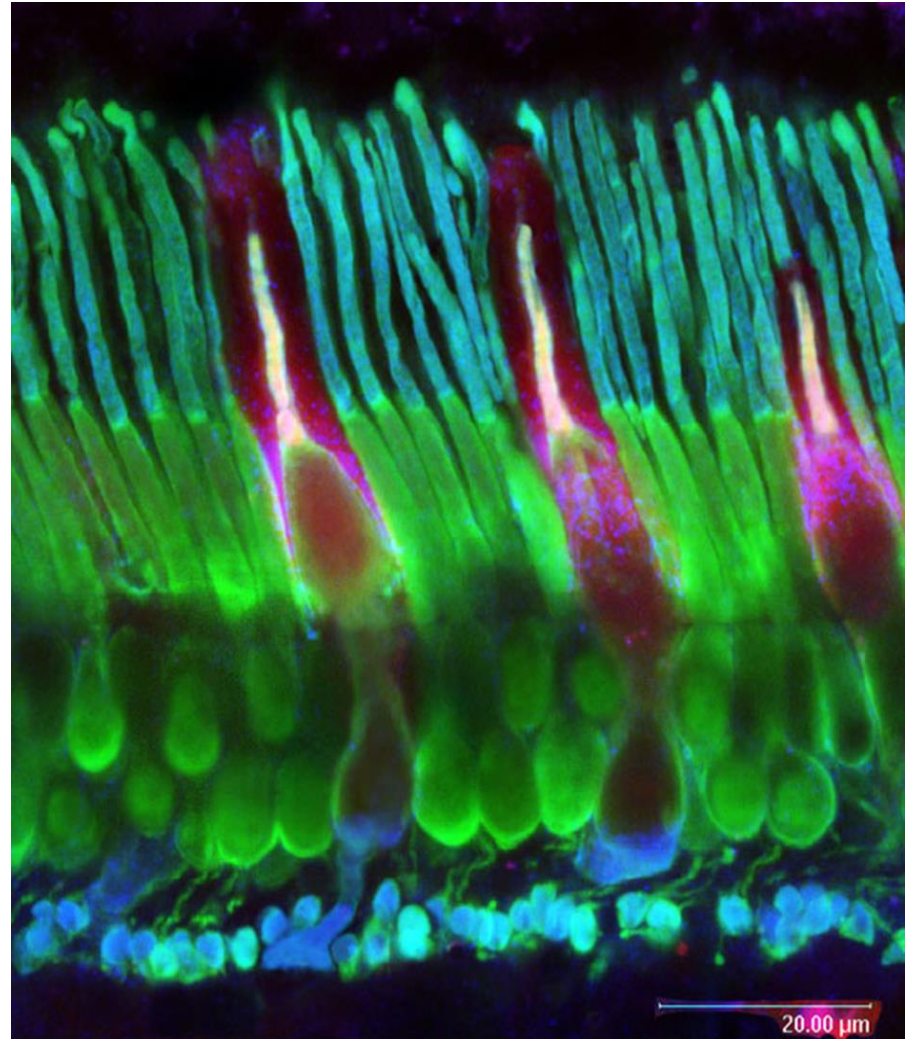

Macula & Fovea Centralis

- An important part of the retina is the **Macula Lutea** .
- At the center of the Macula we find the **Fovea Centralis** .
- In the **Fovea** we find the maximum concentration of cones → consequently → the Fovea is the point of maximal **visual activity** in the retina .
- Cones are densely packed at the Fovea .
- When you turn your eye to look at an object → you tend to place its image in the Fovea

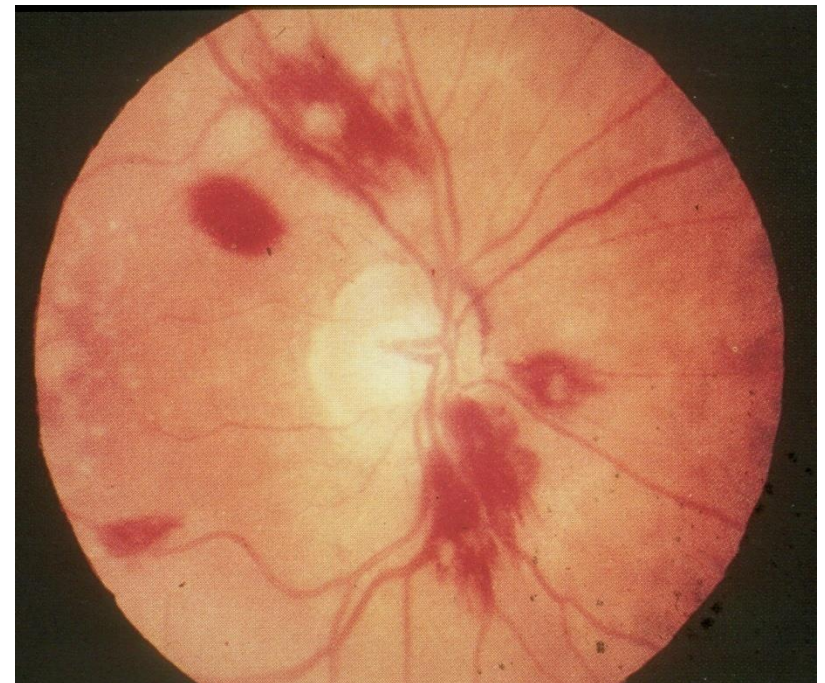
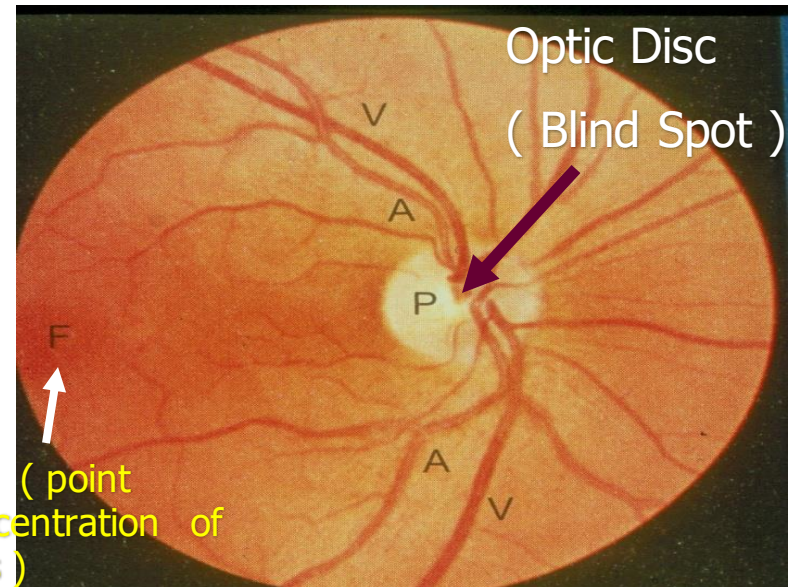

Normal Ophthalmoscopic View of Eye



Disorders of the Eye and Vision: Retinopathy

- Retinopathy in diabetes
 - Vessels have weak walls - causes hemorrhaging and blindness



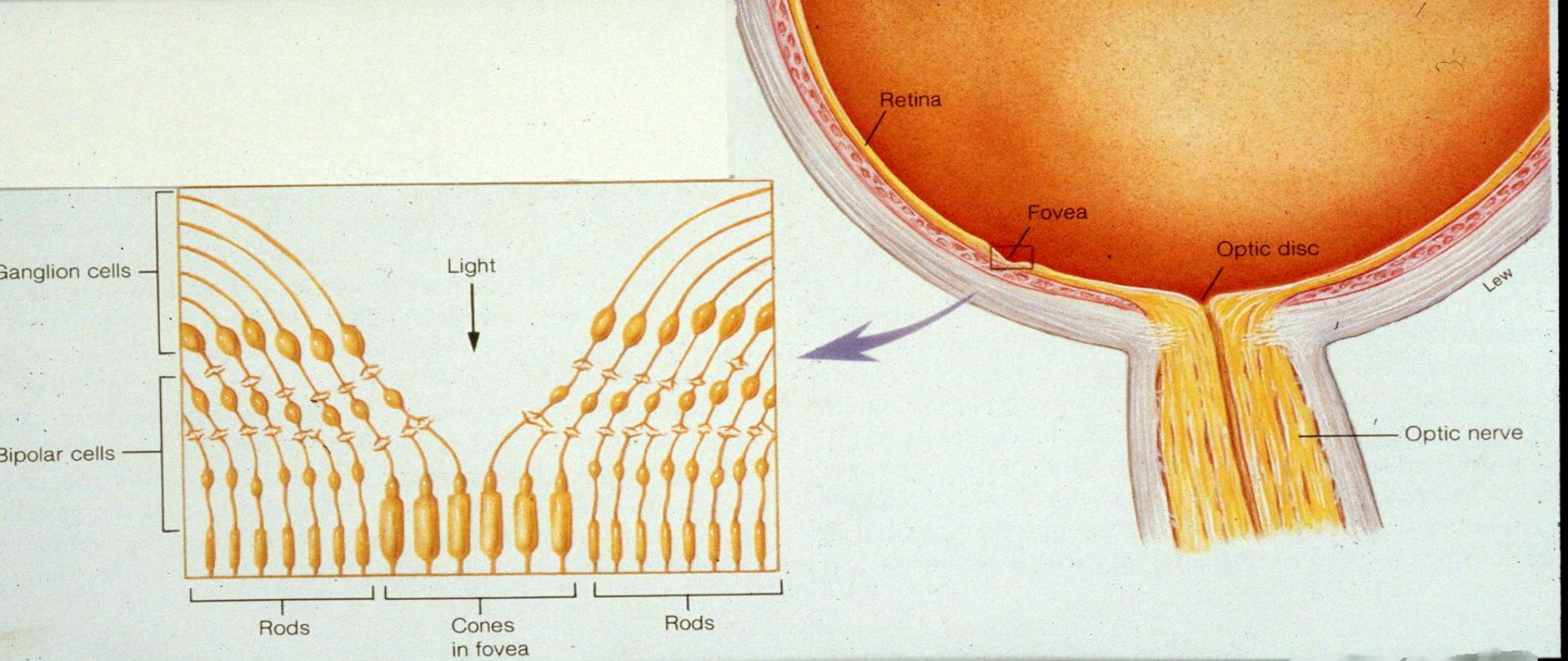

STRUCTURE OF THE EYE

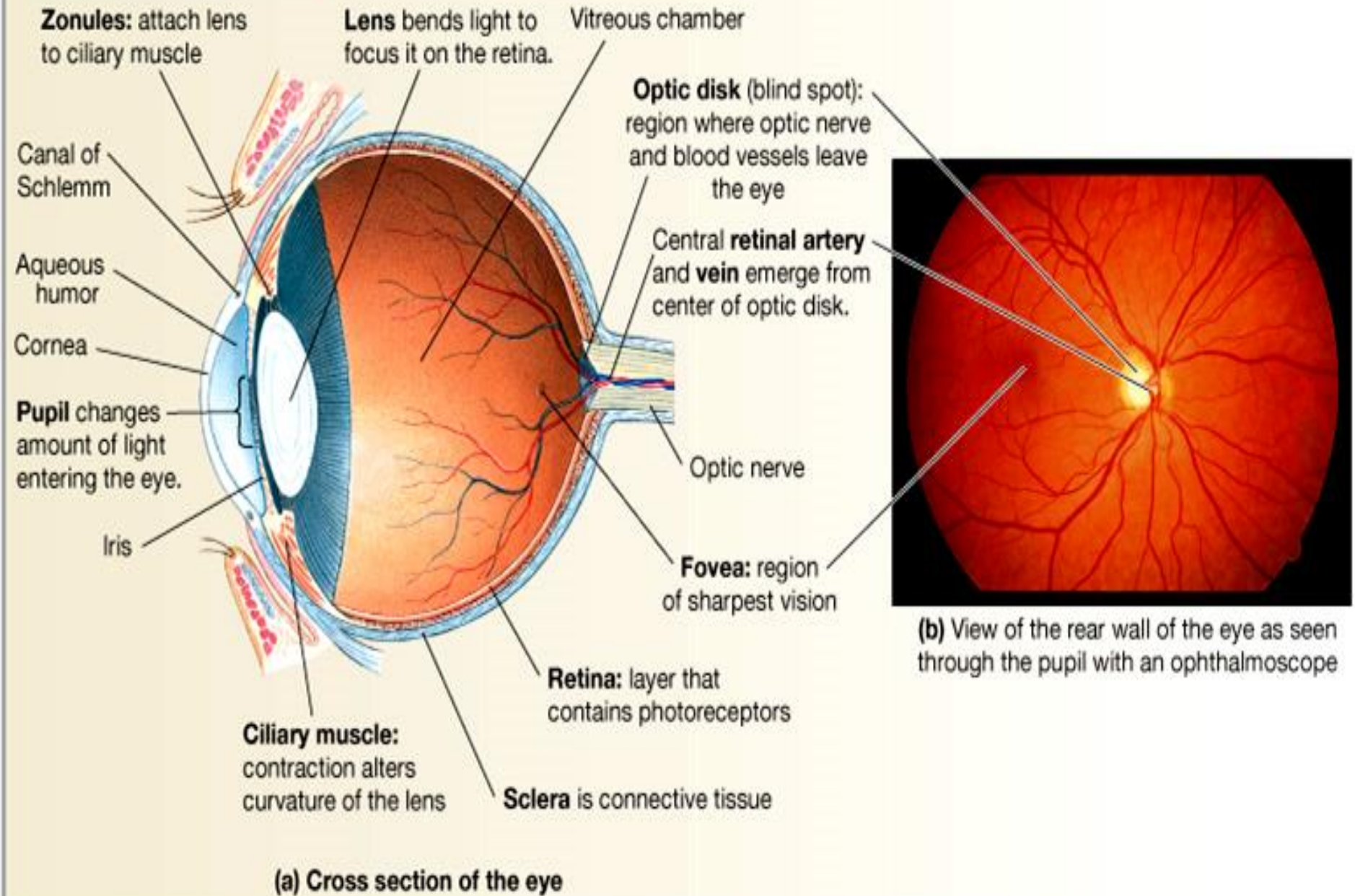

Organization of the Retina

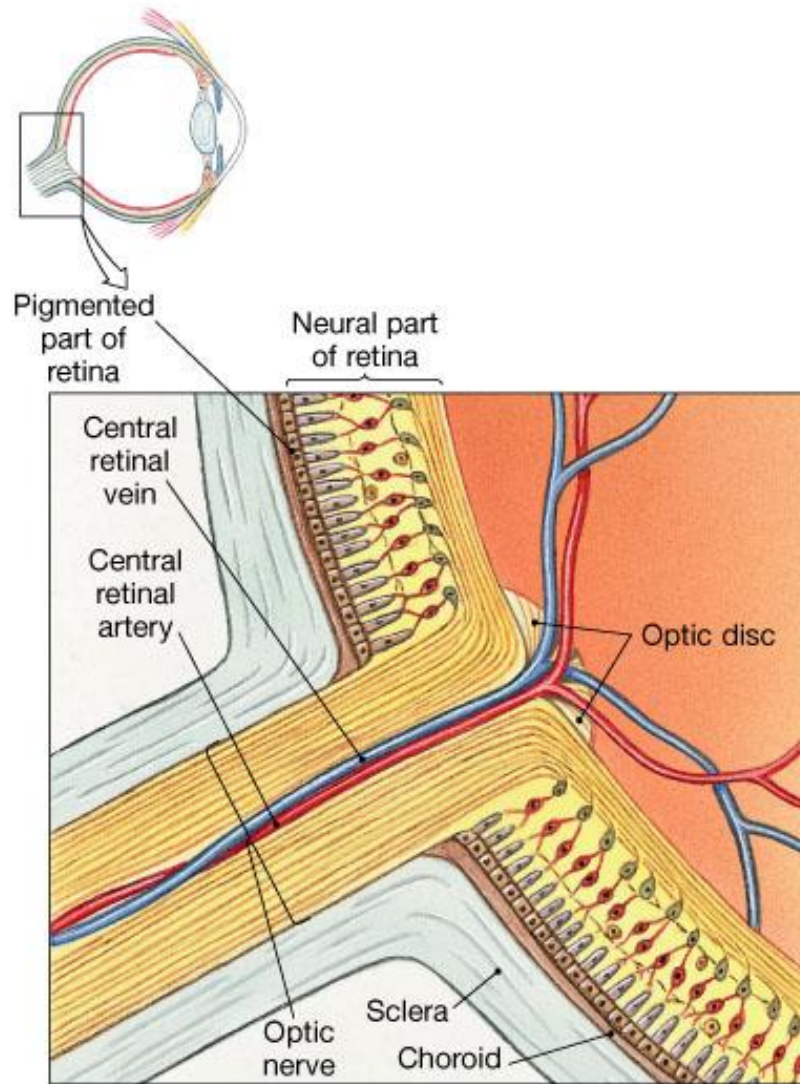

(b)

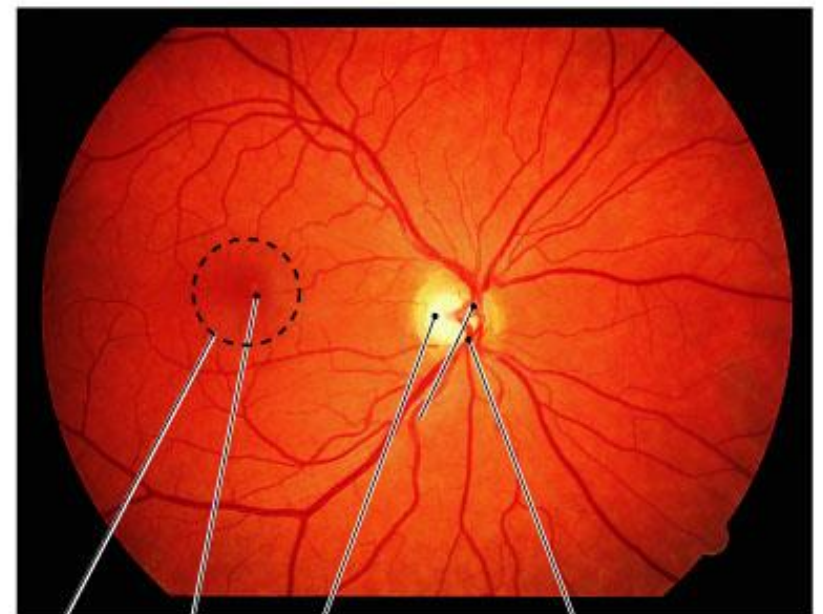

(c)

External Protection of The Eye

- 1. Bony orbit
- 2-Eye lids with their lashes
- 3 Conjunctiva
- 4-Tears from lacrimal gland:
 - has antibacterial, lubricating effect
 - keep cornea moist & clear
 - **provide nutrition to the cornea**

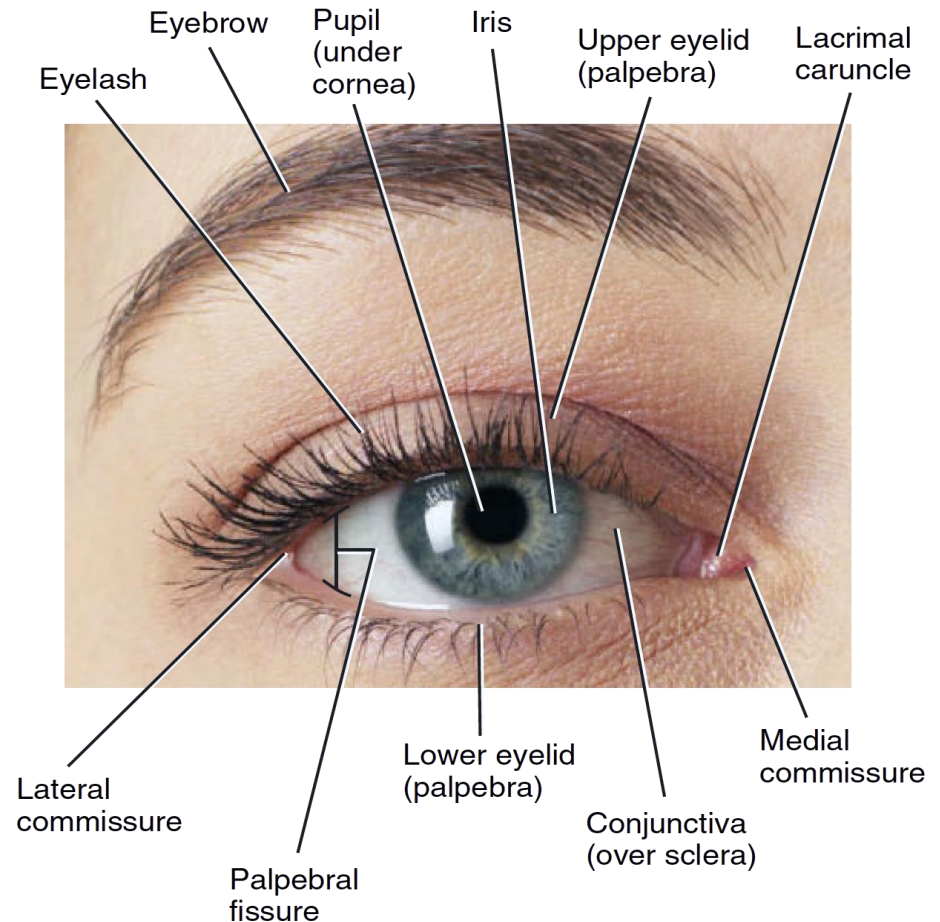

Lacrimal Apparatus

- Lacrimal gland
- Superior and inferior canaliculi
- Lacrimal sac
- Nasolacrimal duct

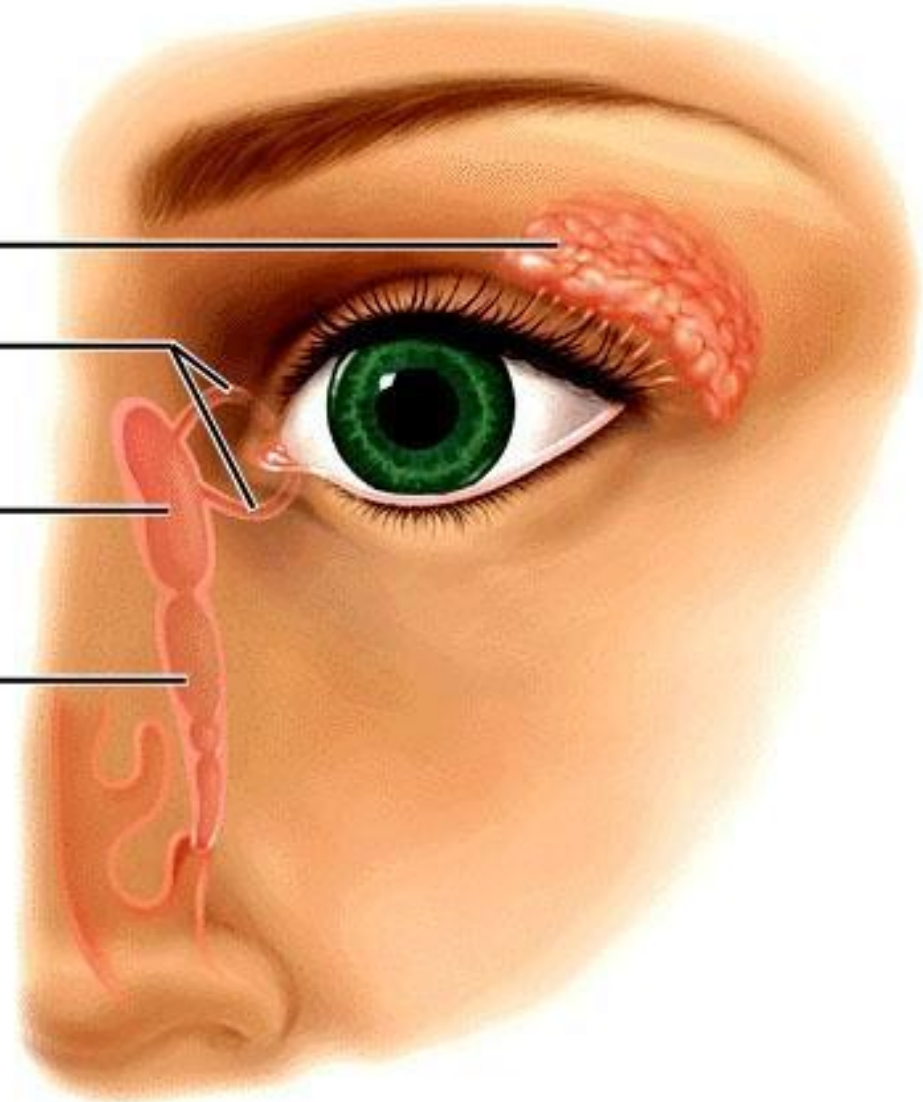

Lenses

Principles of Optics

Image Formation

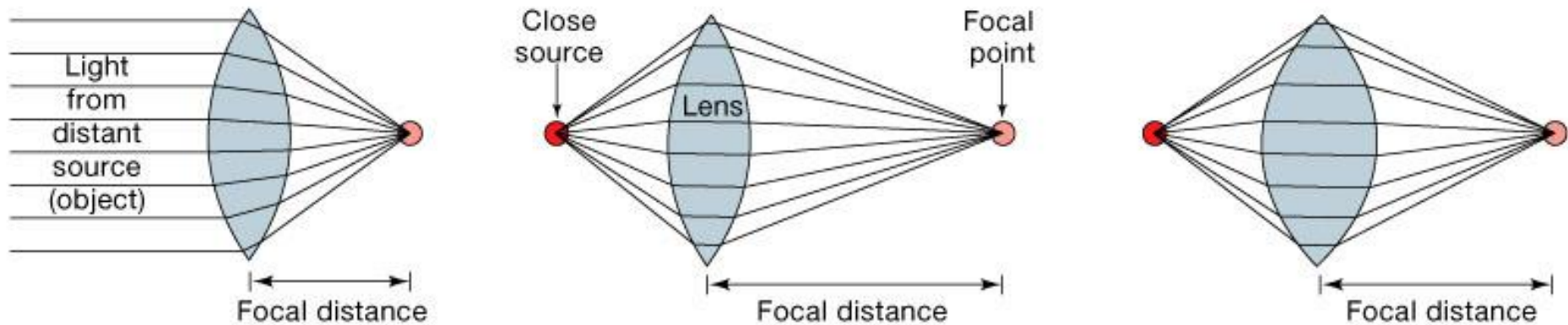

(a) The closer the light source, the longer the focal distance

(b) The rounder the lens, the shorter the focal distance

Principles of Optics

principle focus:-

➤ parallel rays strike biconvex lens refracted in a point is PF.

principle axis:-

➤ PF lies on line pass through centers of lens curvatures

Principal focal distance:-

➤ distance between lens & PF.

➤ Biconvex lens (converge) & biconcave lens (diverge)

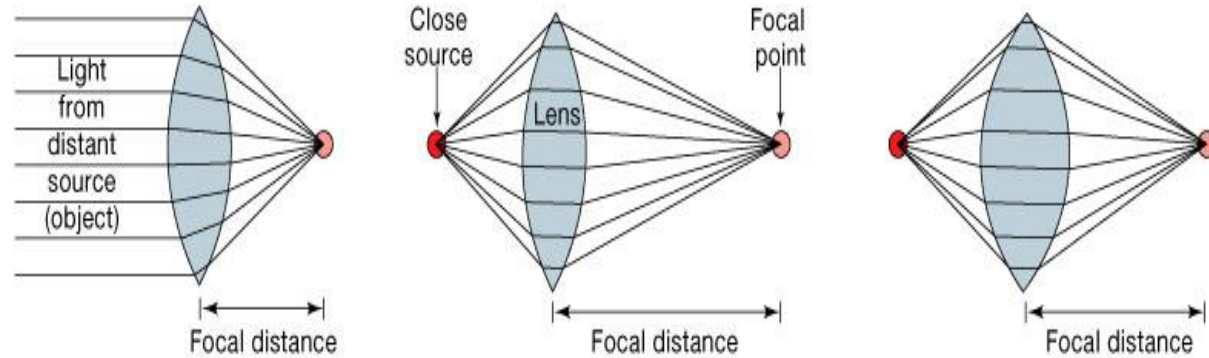

(a) The closer the light source, the longer the focal distance

(b) The rounder the lens, the shorter the focal distance

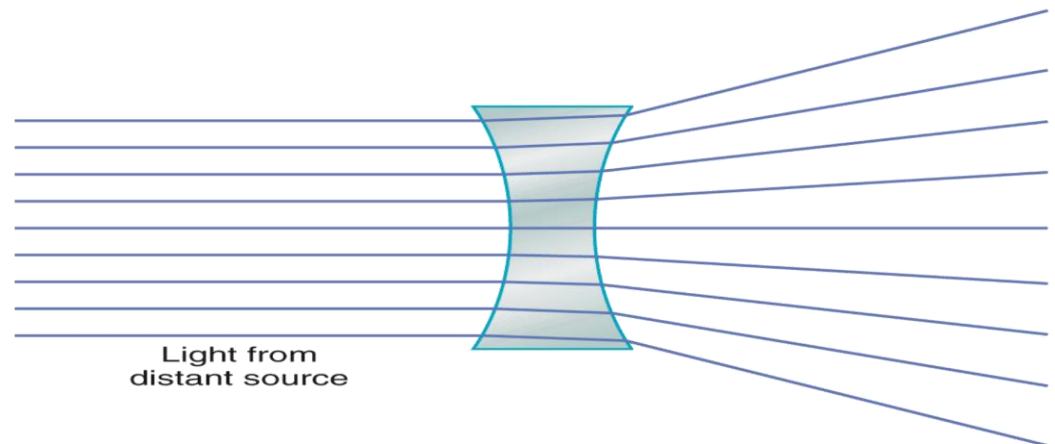

Emmetropic: objects focused on retina (normal)

Diopeter:

- Measure of refractive power) = $1 / \text{Principal focal distance in meters}$
- Exp/ if Principal focal distance of a lens is 25cm, so its R.P = $1 / 0.25$ meter = 4D

Emmetropic eye:-

- Normal eye has image on retina , has dioptric power of 59D
- Lens-retina distance = 17mm
- The greater the curvature of the lens, the greater the refractive power of the eye.

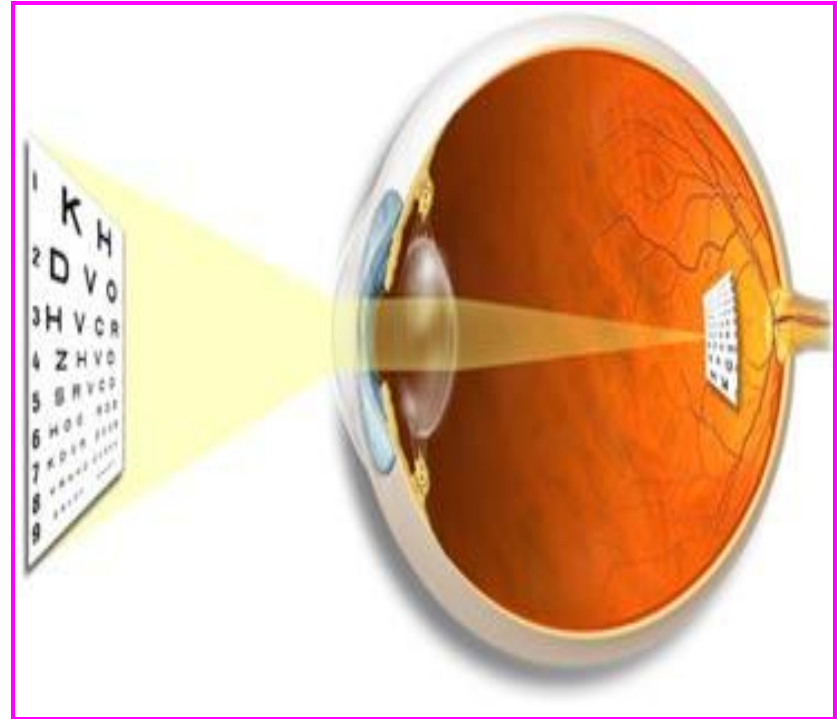

Refractive media of the eye

- (1) The interface between air and the anterior surface of the cornea,
- (2) The interface between the posterior surface of the cornea and the aqueous humor,
- (3) The interface between the aqueous humor and the anterior surface of the lens of the eye,
- (4) The interface between the posterior surface of the lens and the *vitreous humor*.
- - *a total refractive power of 59 diopters when the lens is accommodated for distant*

Refractive media of the eye-2

1. The Cornea

- Its dioptric power is 40-45 diopter at its anterior surface.
- About two thirds of the 59 diopters of refractive power of the eye is provided by the anterior surface of the cornea
- -N.B/ The internal index of air is 1
 - the cornea, 1.38
 - the aqueous humor, 1.33
 - the crystalline lens 1.40
 - the vitreous humor 1.34.

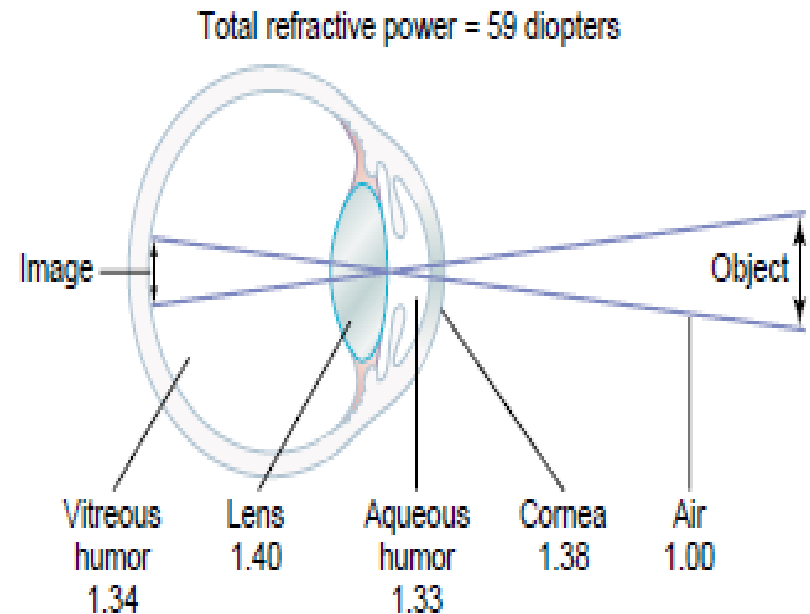

Figure 49-9

The eye as a camera. The numbers are the refractive indices.

2. Aqueous Humor

- Fluid produced by ciliary body (ciliary processes)---to post chamber-----to pupil---to ant chamber----to canal of schlemm at angle of ant chamber---to veins

Function:

- Nourishing a vascular structures (cornea ,lens)
- Causes intraocular pressure 10-20mm Hg
- Produced at a rate of 2-3 microliter/min by active transport of Na^+ , followed by Cl^- and HCO_3^- and then osmosis of water
- Contains many nutrients like amino acids , ascorbic acids and glucose

Aqueous Humor-2

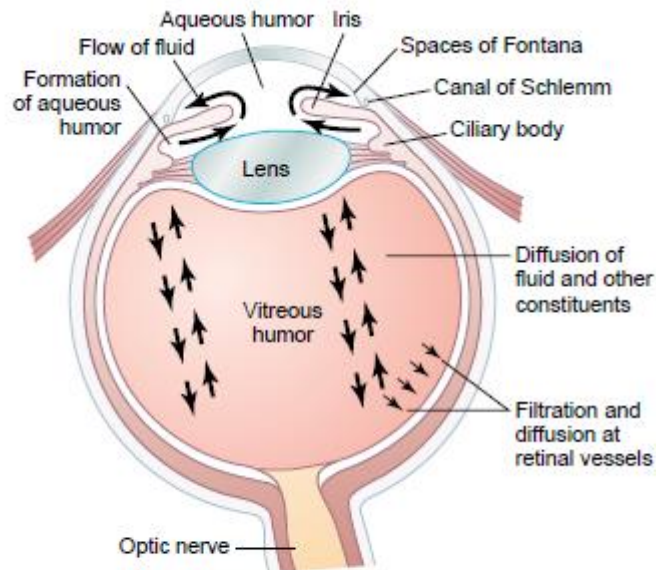

Figure 49-19

Formation and flow of fluid in the eye.

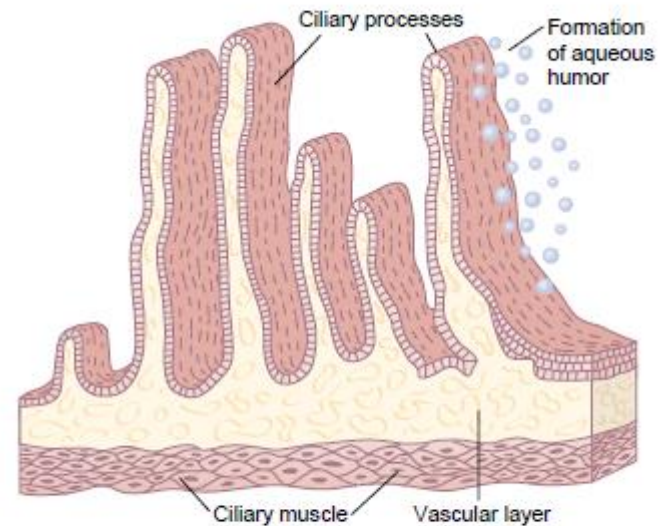
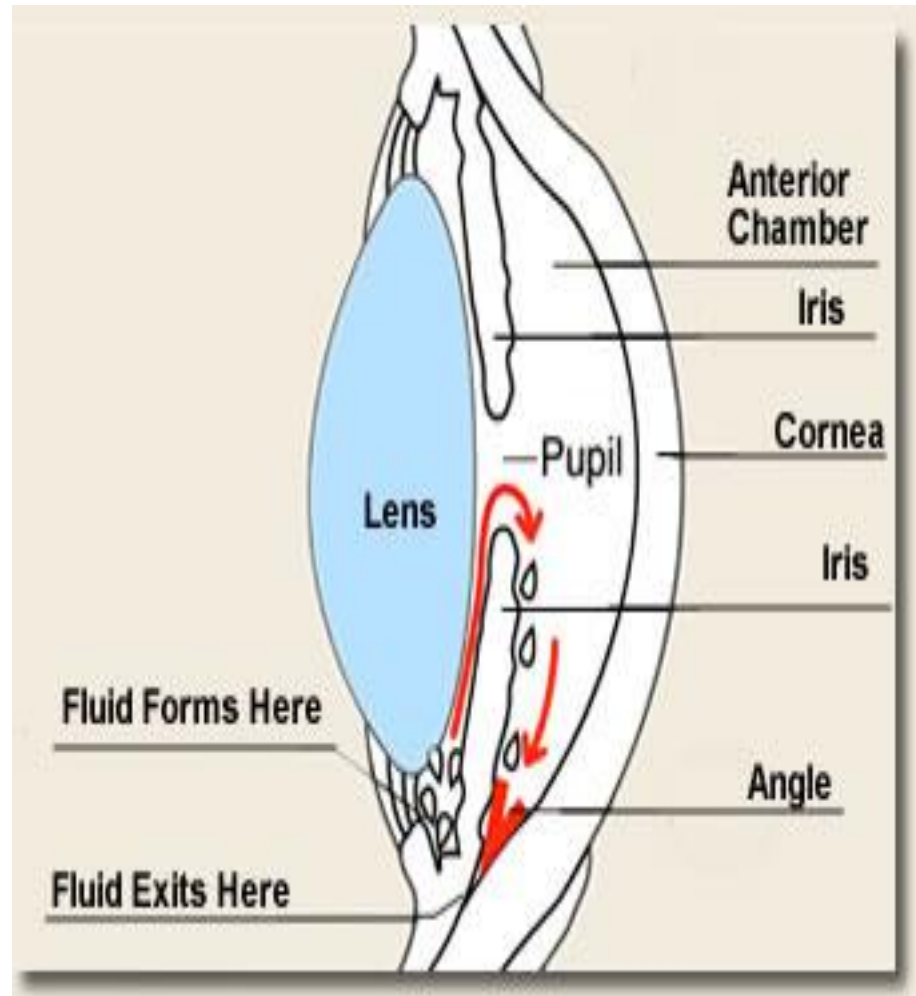

Figure 49-20

Anatomy of the ciliary processes. Aqueous humor is formed on surfaces.

Glaucoma

- Build up of Aqueous Humor Volume
- Increases pressure in eye
- Damages nerve
- Meds/surgery





Normal Vision

Glaucoma

Glaucoma is an eye condition that develops when too much fluid pressure builds up inside of the eye. The increased internal pressure can damage the optic nerve, which transmits images to the brain. Without treatment, glaucoma can cause blindness within a few years. Glaucoma is most often inherited, meaning it is passed from parents to children. Less common causes of glaucoma include a blunt or chemical injury to the eye, severe eye infection, blockage of blood vessels in the eye and inflammatory conditions of the eye. Glaucoma usually occurs in both eyes, but it may involve each eye to a different extent.



3. The Vitreous Humor

- Is the transparent, colorless, gelatinous mass
- It fills the vitreous chamber between the lens of the eye and the retina
- The vitreous humour is clear and allows light to pass through
- For nourishing retina & keep spheroid shape of the eye
- Both water and dissolved substances can diffuse slowly in the vitreous humors
- **VITREOUS HUMOUR REMAINS FROM BIRTH**

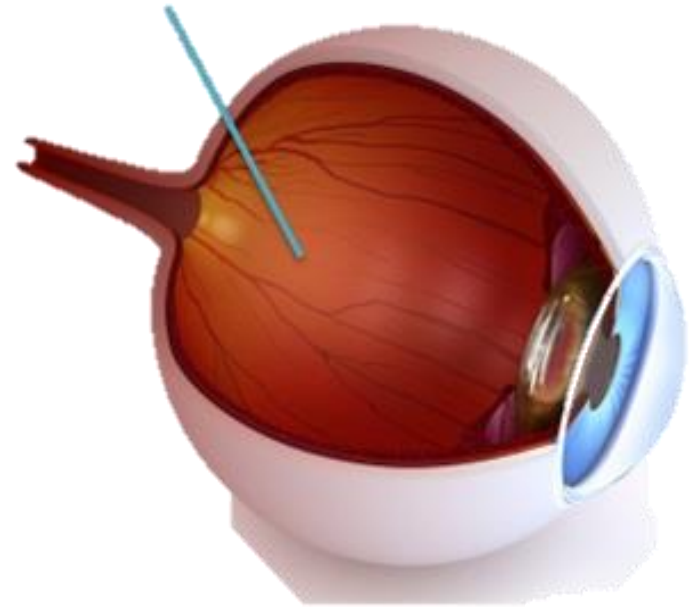

4. The Lens

- Has dioptric power 15-20 D
- (1/3 refractive power of eye) , more important than cornea.
- why?
- Importance of the internal lens is that, in response to nervous signals from the brain, its curvature can be increased markedly to provide "accommodation"

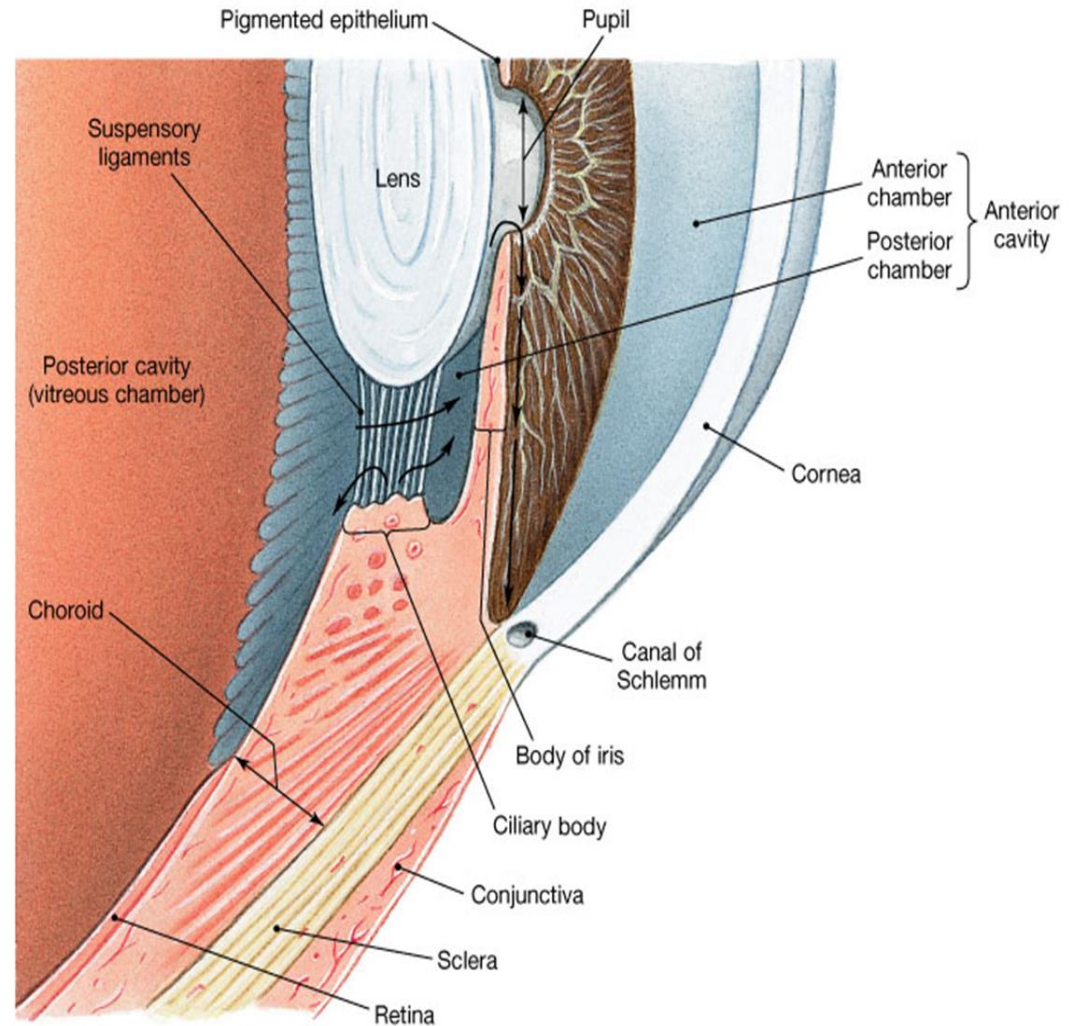

Cataracts



- Lens clouds up
- Must be removed
- Typical to replace lens with implant
- Can get clouding repeated
- Laser removal

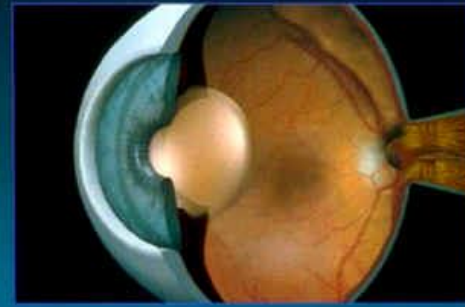
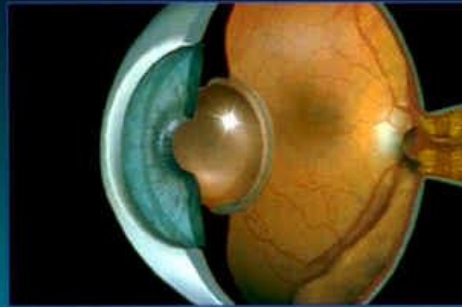

Binocular Vision

▪ Are the areas in the centre of visual field of the two eyes in which any object in this area will be seen by both eyes.

BINOCULAR VISION for:

- 1- Large visual field
- 2- cancel the effect of blind spot
- 3- stereoscopic vision
- 4- one eye lesion does not affect vision

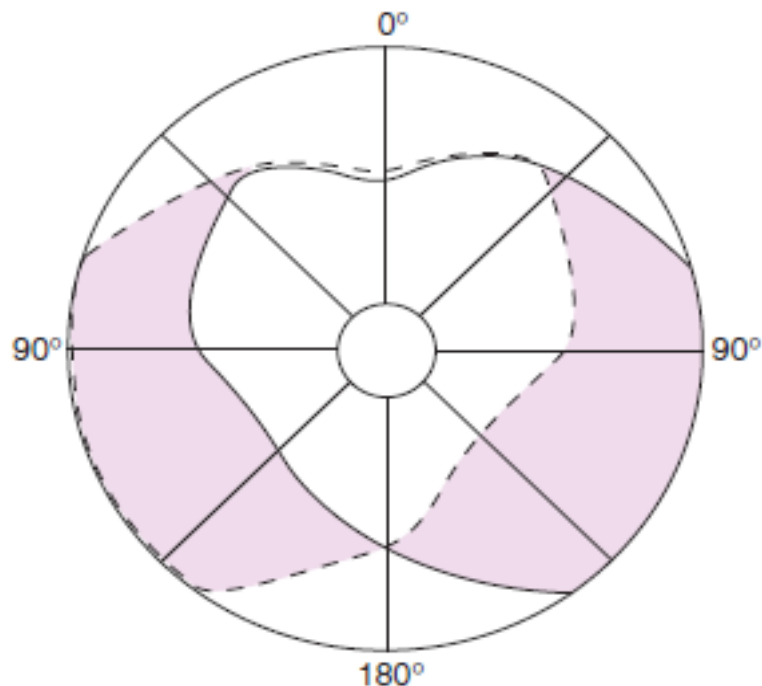

Monocular and binocular visual fields. -The dashed line encloses the visual field of the left eye; -the solid line, that of the right eye. -The common area (heart-shaped in the center) is viewed with binocular vision. -- The colored areas are viewed with monocular vision.

Errors of Refraction

- ❑ Hypermetropia (long sight)
- ❑ Myopia (Short sight)
- ❑ Astigmatism
- ❑ Presbyopia

Normal eye (Emmetropia)

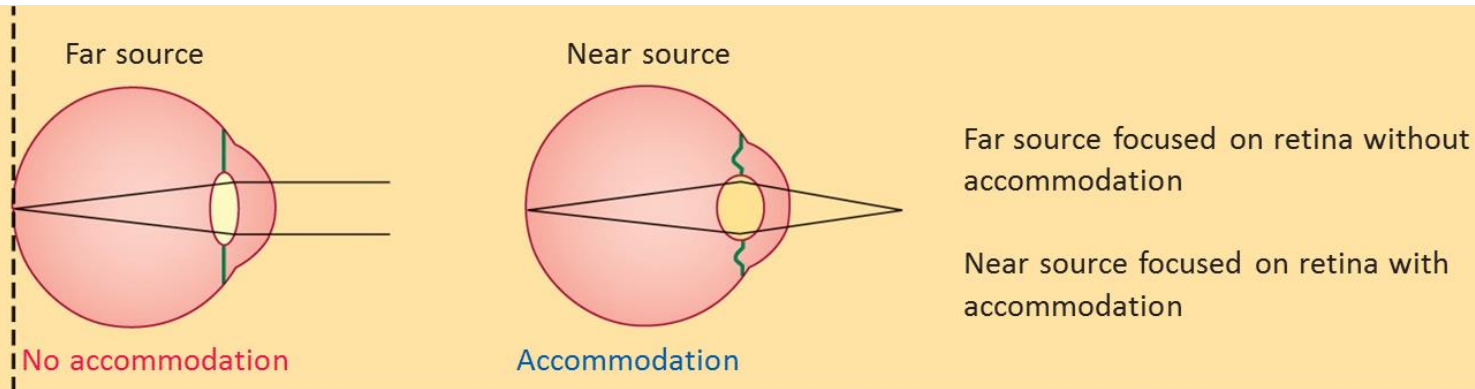

1- Hypermetropia (hyperopia = far-sightedness)

- Short eyeball, focus behind retina,
- An affected individual has to use accommodation even for distant objects.
- Continuous accommodation to bring image on retina causes muscular effort on ciliary muscle & prolonged convergence, this leads to headache & finally squint
- **correction by biconvex lens.**

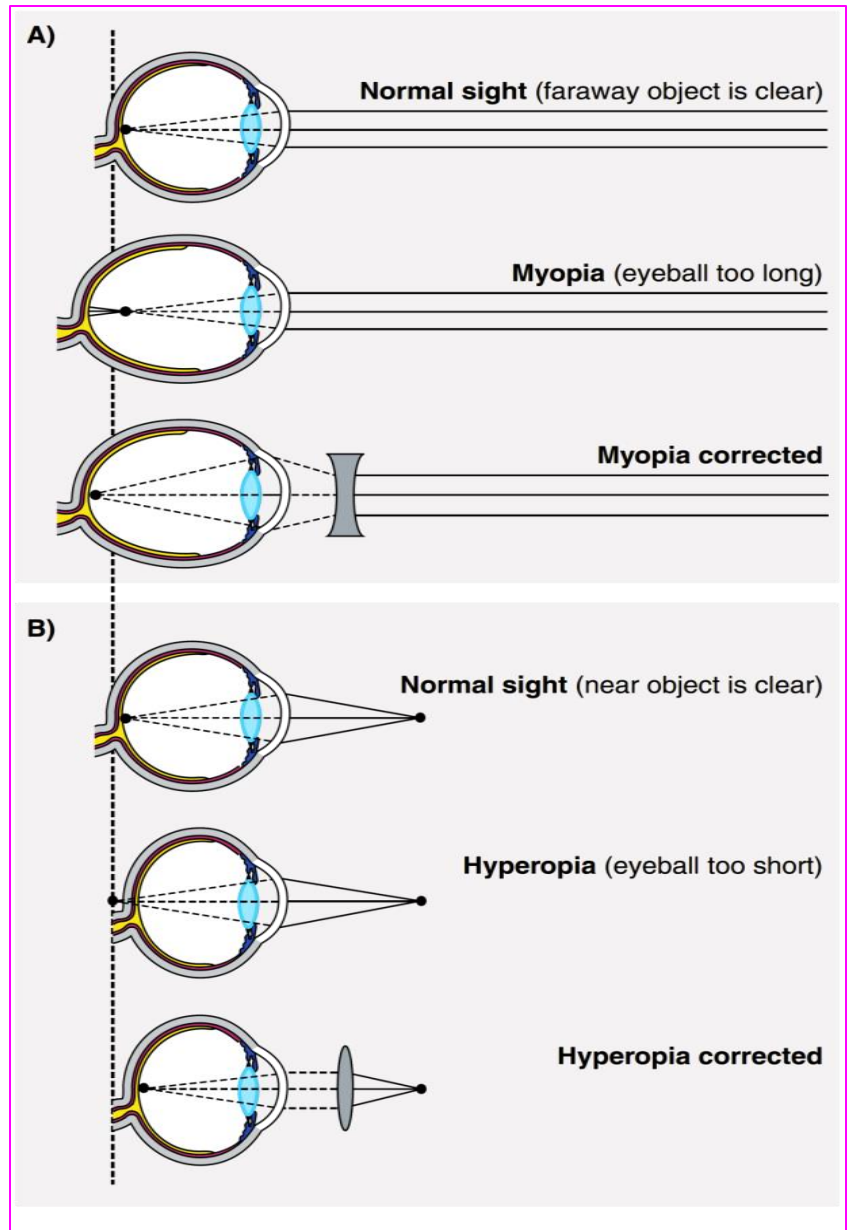

2- Myopia(nearsightedness)

- Genetic, large eye ball, long anteroposterior diameter, cause image to focus in front of retina

Causes of myopia:

- Myopia is thought to be partially genetic in origin
- However, there is a positive correlation between sleeping in a lighted room before the age of 2 and the subsequent development of myopia.
- In young adults the extensive close work involved in activities such as studying accelerates the development of myopia
- Correction by **biconcave** lens to diverge rays before strike lens)

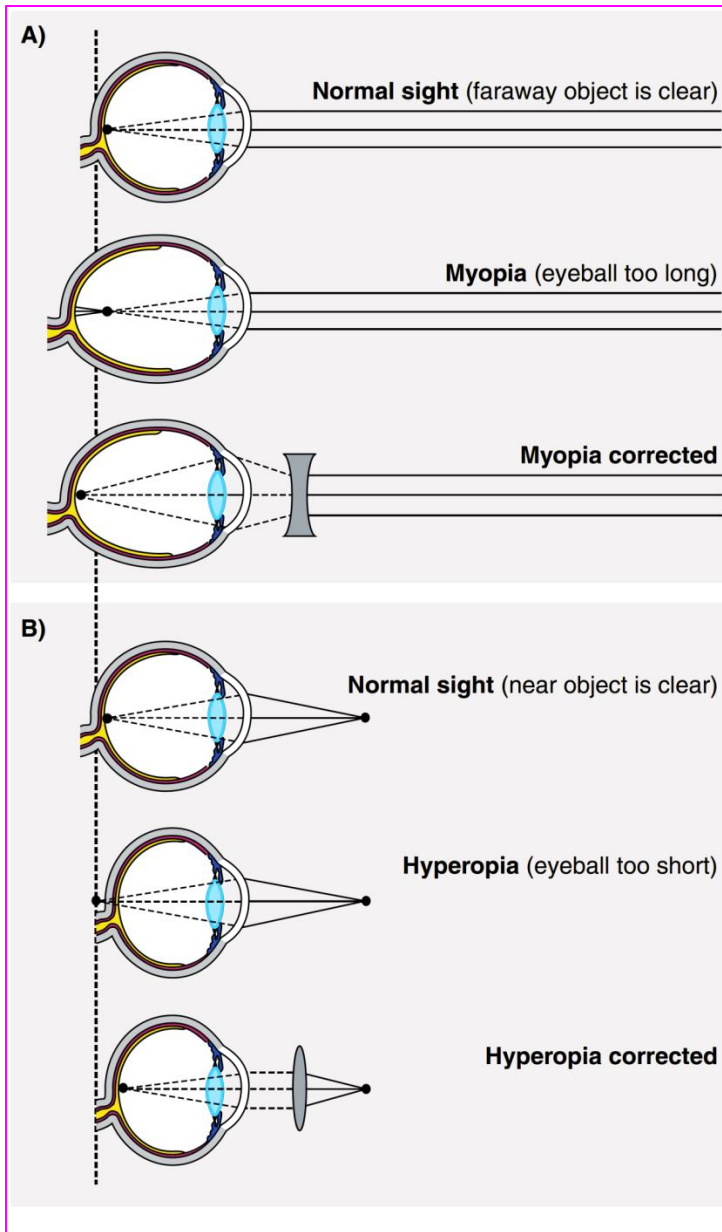
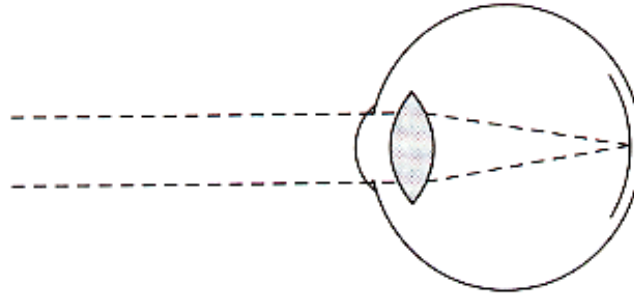

Image Focusing

Emmetropia
(normal vision)

EMMETROPIA
(eyeball length
just right)



Fully relaxed
unaccommodated
lens

Myopia
(Short sight)

MYOPIA
(eyeball length
too long)

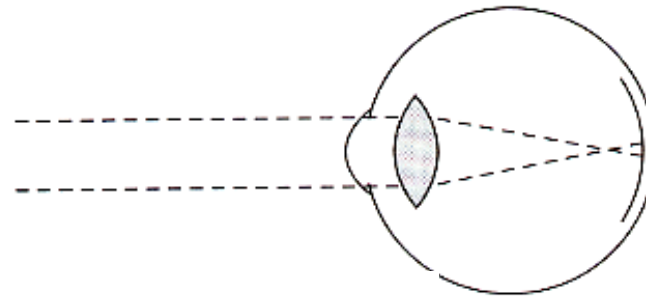

Hyperopia
(long sight)

HYPEROPIA
(eyeball length
too short)

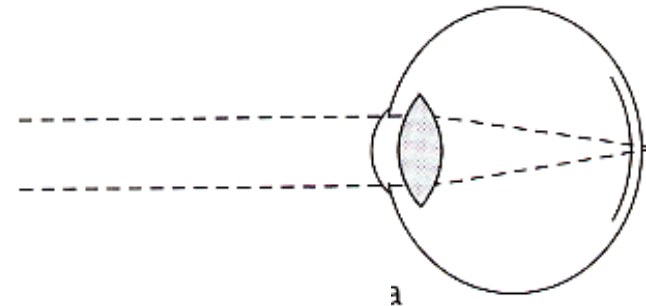

Visual Abnormalities

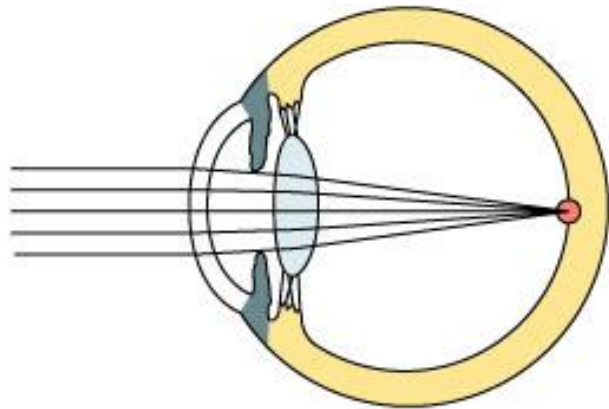

(a) Emmetropia

Normal

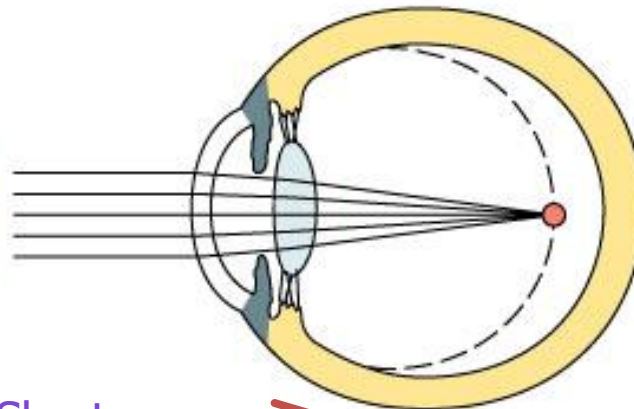

Short-sighted

(b) Myopia

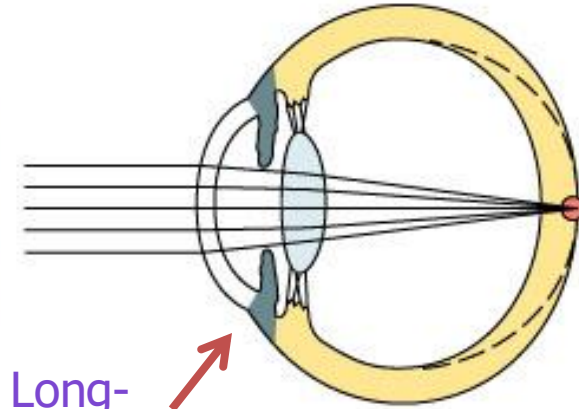

Long-sighted

(c) Hyperopia

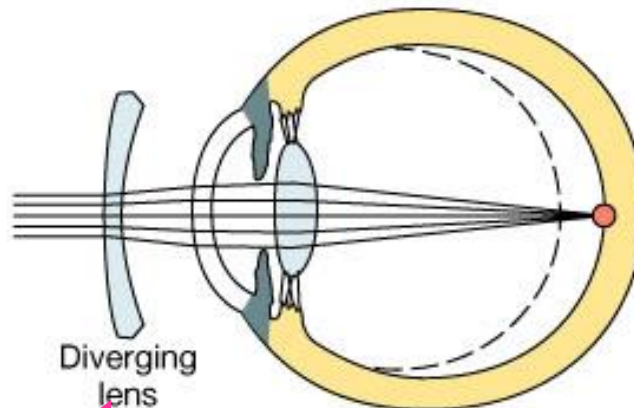

Diverging lens

(d) Myopia (corrected)

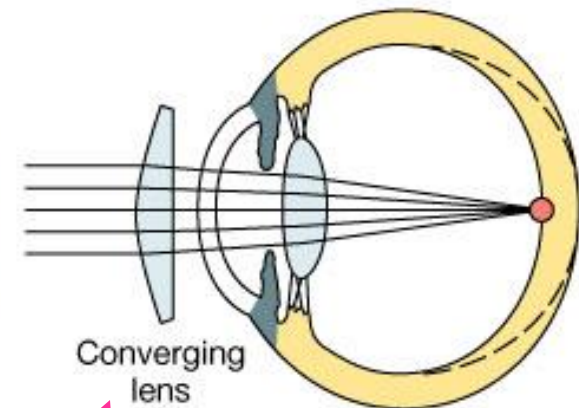

Converging lens

(e) Hyperopia (corrected)

3. Astigmatism

- Uneven & ununiformed corneal curvature, very rare ununiformed lens curvature
- Rays refracted to diff focus-----blurred vision
- Correction by **cylindrical lens**

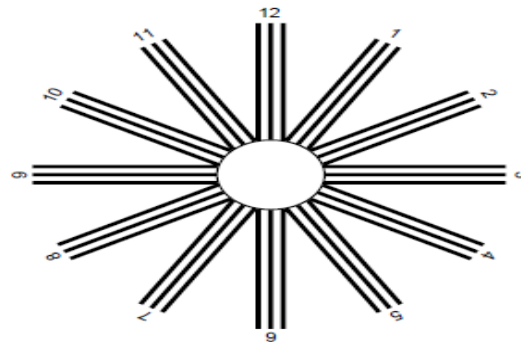
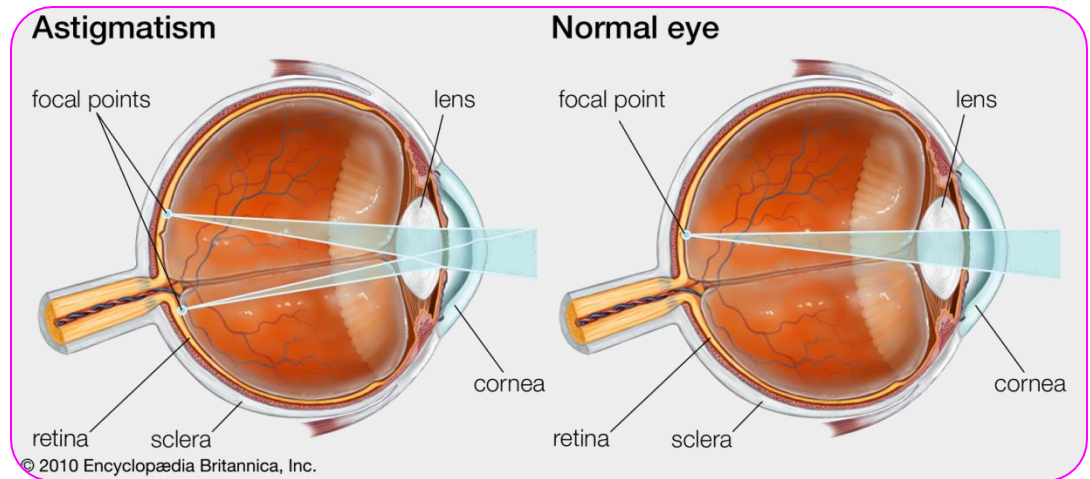

Astigmatism

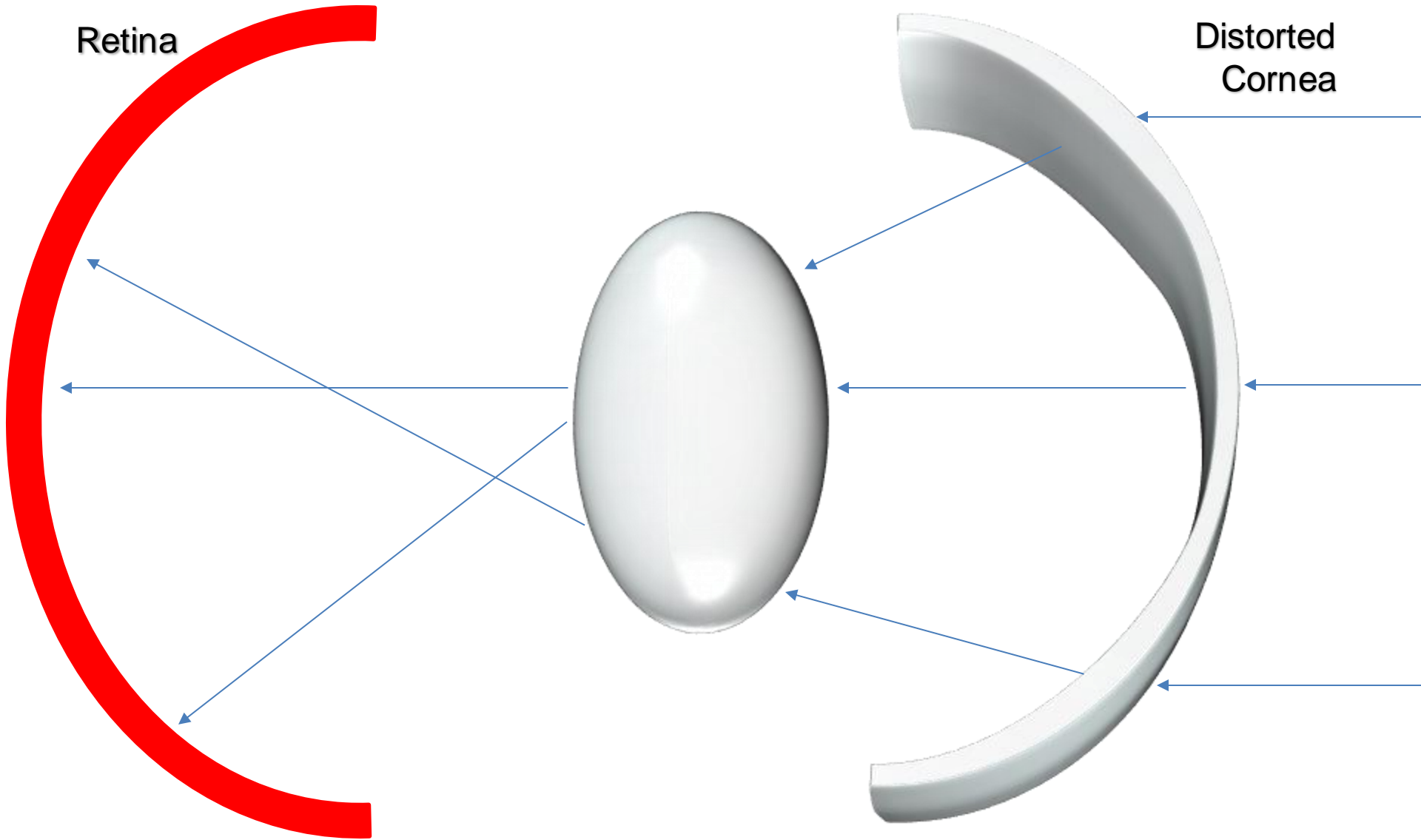

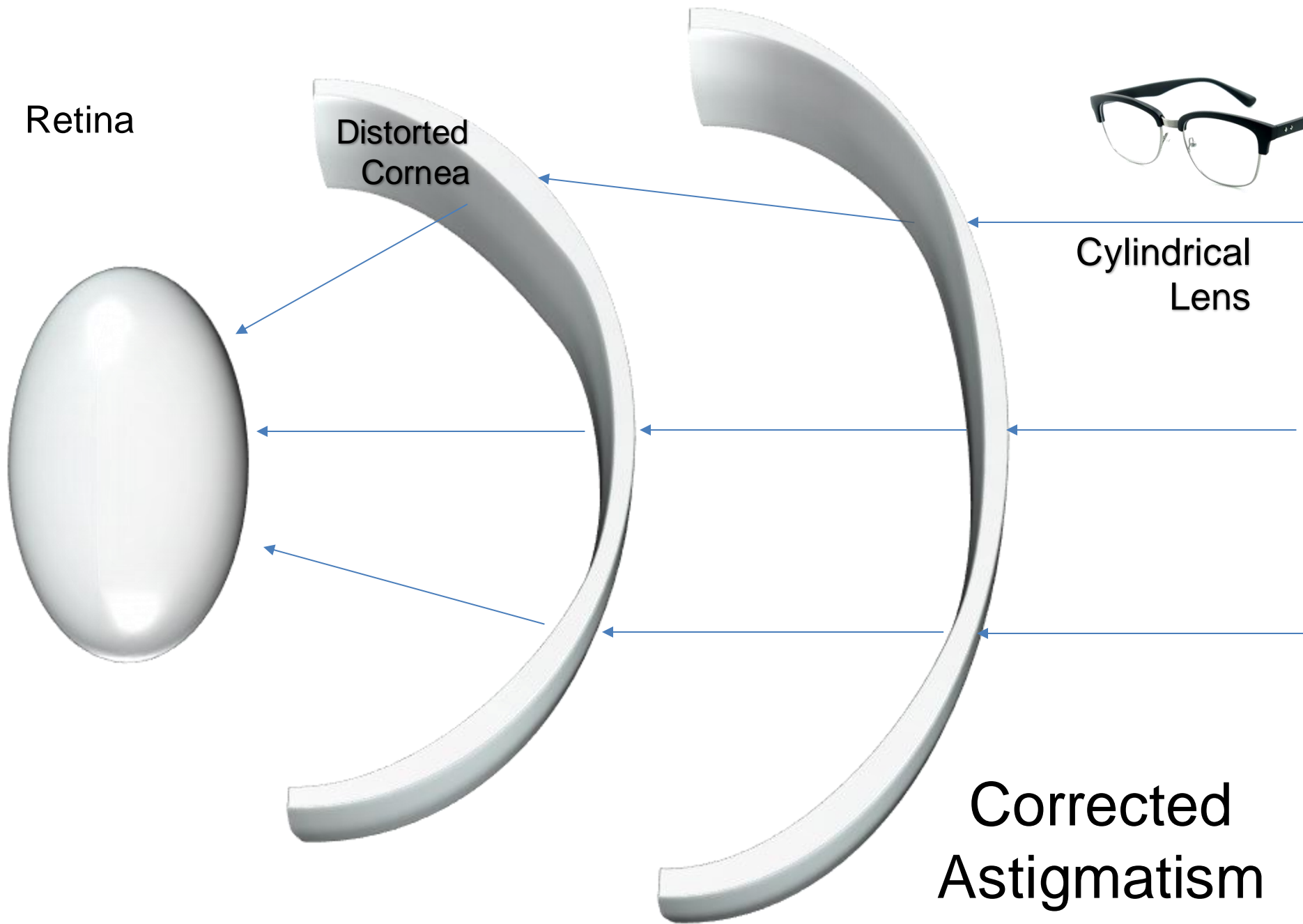

Presbyopia

- Eye near point recedes by age due to loss of accommodation - -Focus behind retina - -correction by biconvex lens

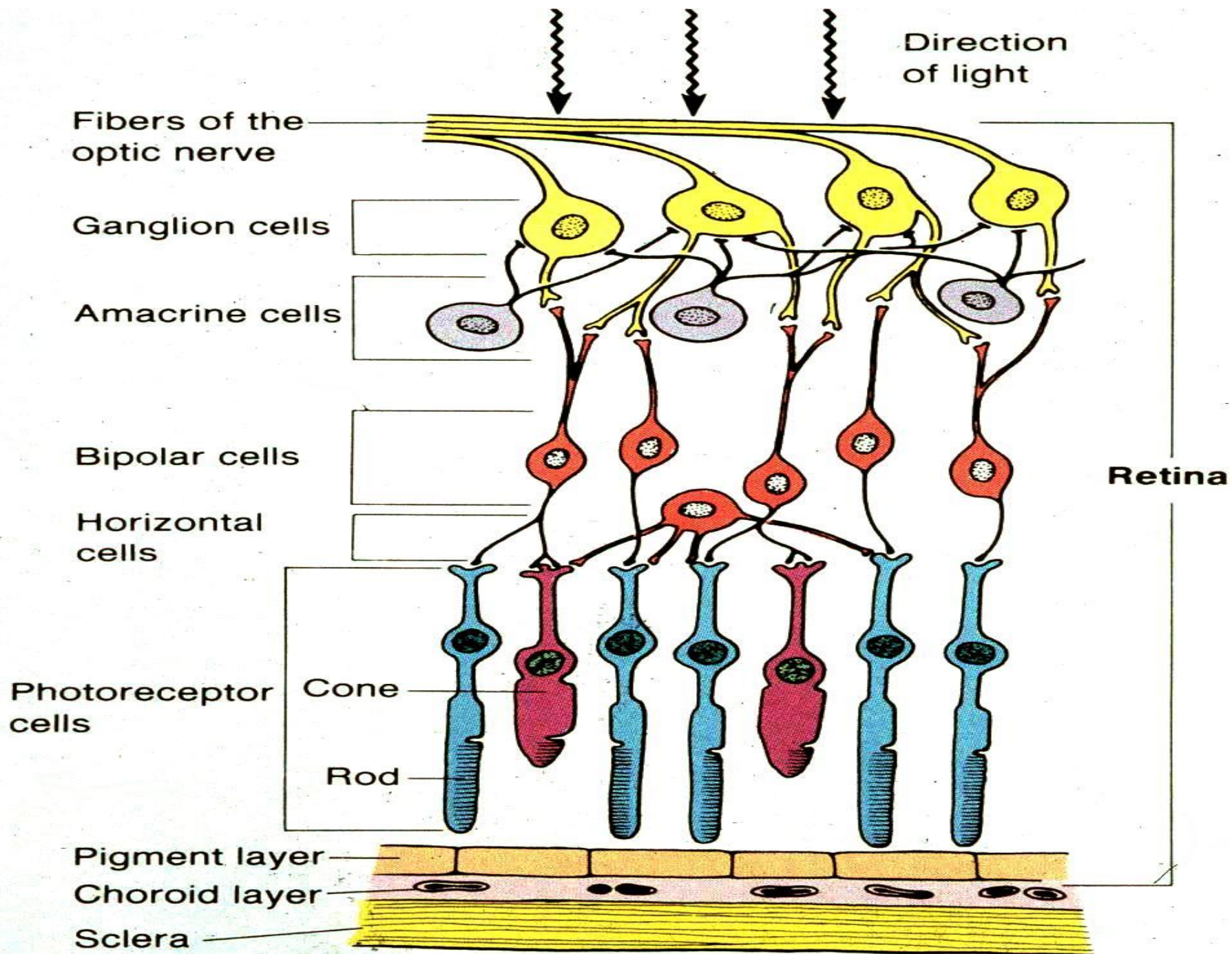

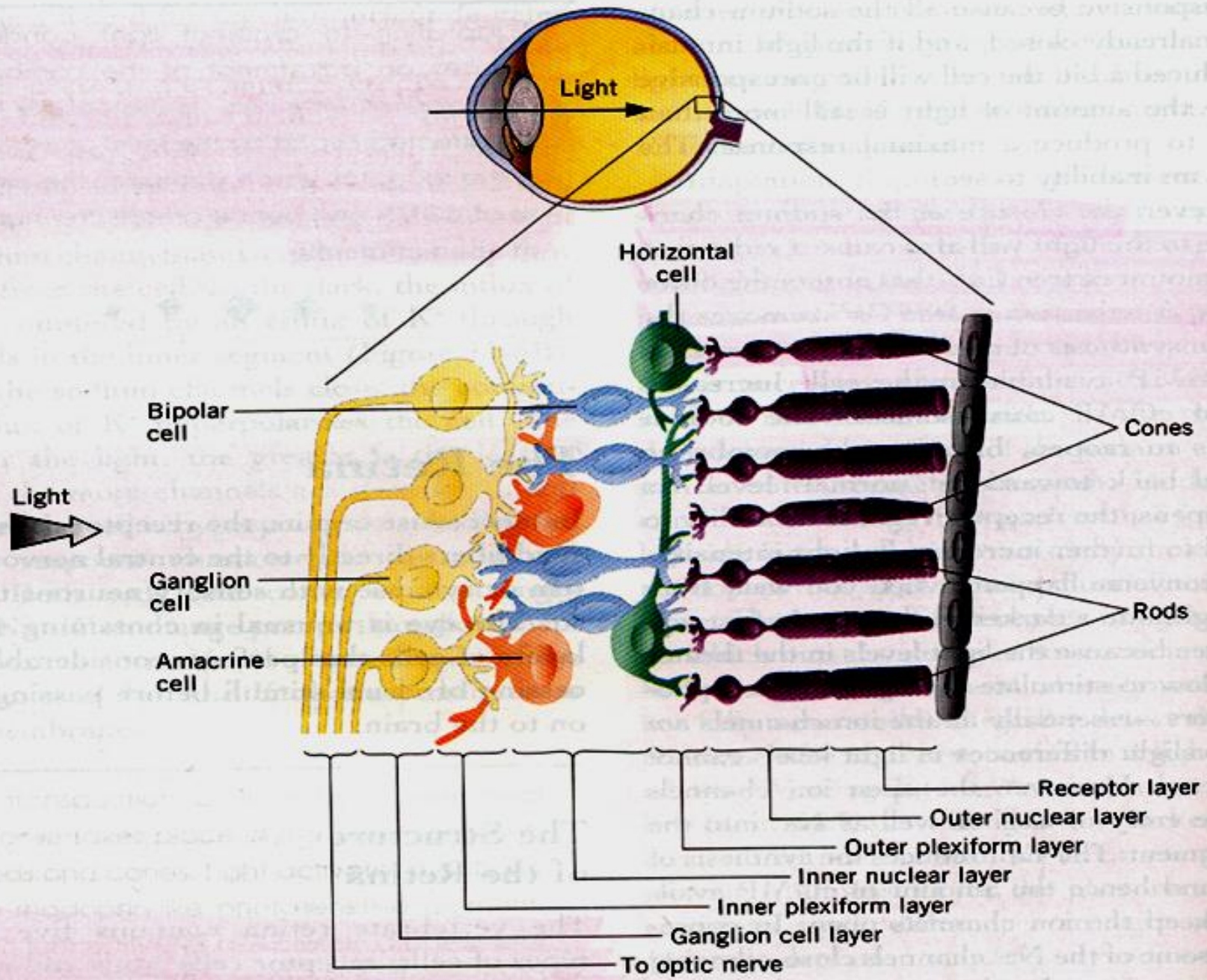

Retina: Neural Circuitry

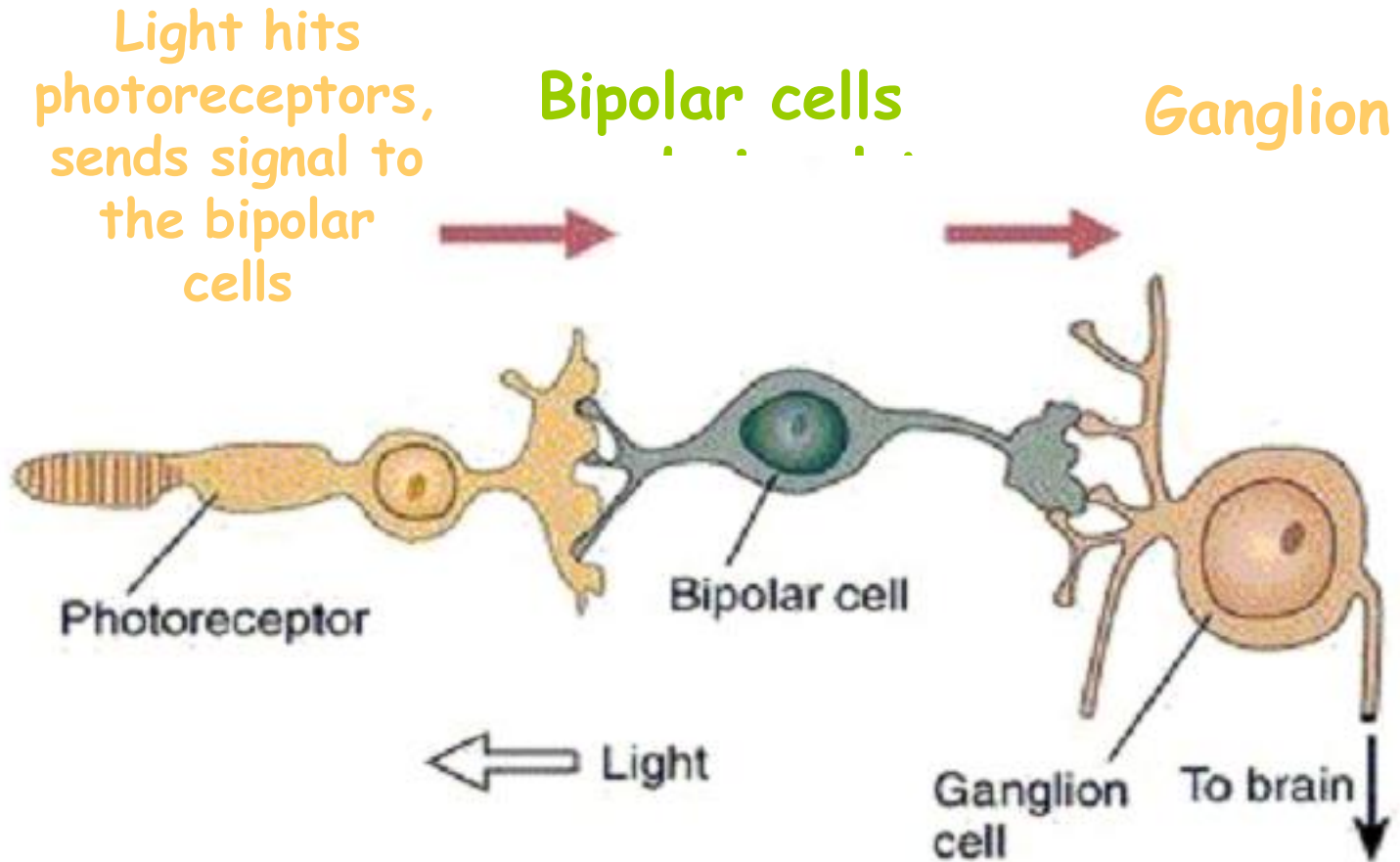

A dramatic sunset or sunrise over a savanna landscape. The sky is filled with large, dark clouds, some of which are illuminated from below by the sun, creating a golden glow. Sunbeams (crepuscular rays) are visible, radiating from the sun's position behind the clouds. The sun is partially obscured by a large, dark cloud mass in the center. The foreground shows the silhouettes of several acacia trees against the bright, orange and yellow sky. The overall mood is serene and majestic.

THANK YOU