

Anesthesia Book 2015

045 Anesthesia team



Chapter 1 preoperative evaluation

Preoperative evaluation is used to assess the anaesthetic risks in relation to the proposed surgery, to decide the anaesthetic technique (general, regional, or a combination) and to plan the postoperative care including any analgesic regimens. Explanation of the relevant details of the anaesthetic can be given, and the use of premedication can be discussed. Patients waiting for surgery are vulnerable, therefore a friendly, professional approach by the anaesthetist is essential.

Operations are classified into four groups (Box).

Box Classification of operations

- **Emergency:** immediate operation within one hour of surgical consultation and considered life-saving, for example, ruptured aortic aneurysm repair
- **Urgent:** operation as soon as possible after resuscitation, usually within 24 hours of surgical consultation, for example, intestinal obstruction
- **Scheduled:** early operation between 1 and 3 weeks, which is not immediately life-saving, for example, cancer surgery, cardiac surgery
- **Elective:** operation at a time to suit both the patient and surgeon

This classification has been agreed with the surgeons, but their memory often fails, so do not be surprised to find elective cases suddenly classified as emergencies! This is usually done for surgical convenience.

It is sometimes difficult to convey an overall impression of the complexity of a patient's medical condition and this can be done by referring to one of the five American Society of Anesthesiologists (ASA) Physical Status Classes (Box 20.2). It is important to remember that this only refers to the physical status of the patient and does not consider other relevant factors such as age, and nature and duration of surgery.

How to survive in anaesthesia

Box ASA physical status classes

- ASA 1: normal healthy patient
- ASA 2: patient with mild controlled systemic disease that does not affect normal activity, for example, mild diabetes, mild hypertension
- ASA 3: patient with severe systemic disease which limits activity, for example, angina, chronic bronchitis
- ASA 4: patient with incapacitating systemic disease that is a constant threat to life
- ASA 5: moribund patient not expected to survive 24 hours either with or without an operation
- E: emergency procedure

Preoperative assessment is outlined below:

1 history

- age
- present illness
- drugs
- allergies
- past history (operations and anaesthetics)
- anaesthetic family history
- social (smoking, alcohol)

2 examination

- AIRWAY
- teeth
- general examination

3 specific assessment

4 investigations

5 consent

6 premedication

The history of the present illness is important. For example, in orthopaedic surgery, a fractured neck of femur may occur for many reasons: a fall from an accident, stroke, cardiac episode (Stokes-Adams attack) or a spontaneous fracture from a metastasis.

The subsequent examination and investigations are obviously different in each case. Details of any previous anaesthetics may indicate difficulties with endotracheal intubation. Unfortunately, successful intubation in the past is no guarantee of future success. A family history of cholinesterase deficiency and malignant hyperthermia should be sought.

Preoperative evaluation

A specific assessment of the concurrent disease(s) must also be undertaken. The problem of obesity is evaluated as shown in Box .

Box Specific assessment of obesity

- Psychological aspects
- Drug metabolism
- Associated diseases
 - hypertension
 - coronary artery disease
 - diabetes
- Difficult venous access
- Airway
 - difficult to intubate
 - difficult to maintain
- Hypoxaemia more likely intraoperatively – ventilation mandatory
- Regional anaesthesia – difficult to perform
- Position of patient for surgery
- Postoperative analgesia and physiotherapy to decrease chest complications
- Immobility and deep vein thrombosis – prophylaxis
- Wound dehiscence and wound infection

Only appropriate investigations should be undertaken. A typical list of basic tests is shown in Box .

Box Basic preoperative tests

- Haemoglobin concentration
- Screening for sickle cell disease
- Blood urea, creatinine and electrolyte concentrations
- Blood glucose
- Chest x-ray film
- ECG

A lot of money is wasted on unnecessary preoperative tests. When you have taken a history from the patient and conducted the relevant examination, you must then decide what tests, if any, are required. A young, fit sportsman for an arthroscopy requires no further investigation; whereas an elderly West Indian patient who has diabetes, hypertension, coronary artery disease, and needs major vascular surgery, requires all the tests listed in Box 20.4 and probably

How to survive in anaesthesia

more. In many hospitals there are guidelines on the use of preoperative investigations. These can be helpful, as they reflect local practice. For example, you may find that there is far greater use of preoperative chest x-ray films in regions with a high population of recent immigrants to exclude tuberculosis.

On completion of the preoperative assessment, and with the results of the relevant investigations available, a plan for the anaesthetic care of the patient can be decided. The following surgical factors must also be considered:

- When is the operation to occur?
- Who is operating?
- Where is the patient going postoperatively (home, ward, HDU, ITU)?

Occasionally, it is necessary to postpone surgery. This is most often done on medical grounds, for example, to improve cardiac failure, treat arrhythmias and control blood pressure. In the early months of your anaesthetic career, seek senior advice before postponing surgery; this prevents prolonged arguments with surgical colleagues.

Premedication

The use of premedication is declining, although most anaesthetists undergoing surgery demand heavy sedation. The wishes of the patient must be considered. The main reasons for giving premedication are shown in Box 20.5.

Box Reasons for premedication

- Anxiolysis
- Antisialagogue
- Analgesia
- Antiemesis
- Amnesia
- Decreased gastric acidity
- Part of anaesthetic technique (assist induction)
- Prevention of unwanted vagal responses
- Prevention of needle pain

A variety of drugs including opiates, benzodiazepines, anticholinergics, phenothiazines and H₂ receptor blocking drugs are used. It is important to remember that opiates may make patients vomit. Topical EMLA cream can be used to prevent the pain of insertion of a cannula. This eutectic mixture of prilocaine and lignocaine (1 g of EMLA contains 25 mg of each) is applied to

Preoperative evaluation

the dorsum of the hands for a minimum of 1 hour to a maximum of 5 hours before induction of anaesthesia.

Drug therapy

Drug therapy is usually continued throughout the operative period, especially cardiac and antihypertensive drugs. Patients taking oral contraceptives and hormone replacement therapy require thromboprophylaxis with subcutaneous low molecular weight heparin and graduated elastic compression stockings. Potential interactions with anaesthetic drugs should be considered.

Preoperative starvation

An empty stomach decreases the risk of vomiting and regurgitation. Food is usually withheld for 4–6 hours before elective surgery and in some hospitals it is now common practice to allow clear fluids until 2 hours before surgery. For emergency surgery these guidelines are inappropriate and the only safe practice is to assume that the stomach is not empty (see Chapter).

When to ask for advice

A common difficulty for the trainee is when to ask for advice and assistance. We suggest that if you need advice, state you are ringing for advice. If you need a senior member of the team to be present you should say so.

If in doubt, it is always better to inform seniors of the problems and your decisions. Often two minds are better than one and senior anaesthetists need to know what is happening in the department, especially out of routine working hours.

Conclusion

Preoperative assessment is often difficult and its importance should not be underestimated. The anaesthetic care of the patient can only be planned after a thorough assessment, together with the results of relevant investigations, and precise knowledge of the proposed surgery.

Chapter 2 Evaluation of the airway

Experienced anaesthetists teach that there are three fundamental aspects to safe anaesthetic practice: the airway, the airway and the airway. Unanticipated airway problems account for about 40% of overall anaesthetic morbidity and mortality. Therefore, careful airway assessment must be undertaken pre-operatively. This is carried out logically as summarised in Box .

Box Assessment of the airway

- History
- Symptoms
- Examination
 - anatomy and variants
 - medical conditions
 - specific assessment
 - Mallampati scoring system
 - thyromental distance
 - sternomental distance
 - Other tests

History

Any previous anaesthetic history must be obtained. Information about difficulties with endotracheal intubation may be found in old anaesthetic records. Previous successful intubation is not an indicator of its ease. Some patients carry letters or wear Medic-alert bracelets stating their anaesthetic difficulties, whilst others with major problems know nothing about them. Ascertain whether the airway is potentially difficult by checking whether the patient has any of the medical and surgical conditions listed in Box .

How to survive in anaesthesia

Box Medical features of difficult airway intubation

- Congenital: rare
- Acquired
 - traumatic: fractures of mandible and cervical spine
 - infection: epiglottitis, dental or facial abscess
 - endocrine: thyroid enlargement, acromegaly, obesity
 - neoplasia: tongue, neck, mouth, radiotherapy
 - inflammatory: ankylosing spondylitis, rheumatoid arthritis
 - pregnancy

Symptoms

Upper airway obstruction may be found in patients with stridor, dysphagia and hoarseness.

Examination and clinical tests

Normal anatomy and its variants

Some patients appear anatomically normal and yet are difficult, or impossible, to intubate. These patients cause anaesthetists unexpected problems. We have had the occasional experience of casually starting an apparently normal laryngoscopy, only to have the sinking feeling associated with complete failure to see the larynx. It is much better to anticipate a difficulty than encounter one unexpectedly. Some anatomical factors that make airway control and intubation difficult are listed in Box .

Box Anatomical features of difficult airway control and intubation

- Short immobile neck
- Full set of teeth, buck teeth
- High arch palate
- Poor mouth opening – less than three fingers gap between upper and lower teeth
- Receding mandible (may be hidden by a beard)
- Inability to sublux the jaw (forward protrusion of the lower incisors beyond the upper incisors)

Evaluation of the airway

Specific assessment

Several clinical tests to assess the airway are in common use. None are reliable in predicting a difficult airway or intubation and all should be used in combination as this provides a better overall assessment of the airway.

Modified Mallampati scoring system

This predicts about 50% of difficult intubations. The test can be performed with the patient in the upright or supine position. It is based upon the visibility of the pharyngeal structures with the mouth open as wide as possible (Fig. 1.1). Patients are classified as follows:

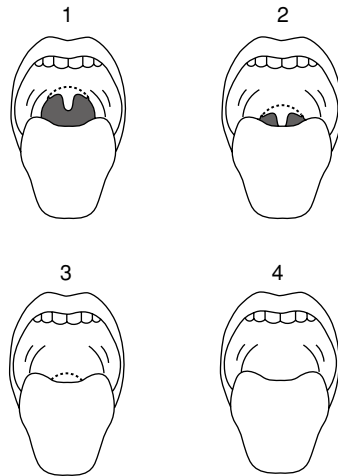

Figure Structures seen on opening of mouth for Mallampati Grades 1–4.

- Grade 1: faucial pillars, soft palate and uvula visible
- Grade 2: faucial pillars, soft palate visible, but uvula masked by the base of the tongue
- Grade 3: soft palate only visible
- Grade 4: soft palate not visible

Patients in Grades 3 and 4 are considered difficult to intubate and those in Grades 1 and 2 are considered feasible intubations. It is important to realise that this system is *not* infallible and patients in Grade 2 sometimes cannot be intubated.

Head and neck movement

Flexion and extension are greater than 90° in normal people.

How to survive in anaesthesia

Jaw movement and mandible

Check that the patient's mouth opens normally. It should have an interincisor gap of greater than 5 cm (about three finger breadths). Check that the patient does not have buck teeth or a receding mandible. Ideally, the lower incisors should be able to be protruded beyond the upper incisors. If these simple tests cannot be performed the airway may be difficult to manage.

Thyromental distance

The thyromental distance (Patil test) is the distance from the thyroid cartilage to the mental prominence when the neck is extended fully (Fig.). In the absence of other anatomical factors, if the distance is more than 6.5 cm, problems should not occur with intubation. A distance of less than 6 cm suggests laryngoscopy will be impossible and for distances of 6–6.5 cm, laryngoscopy is considered difficult, but possible.

This measurement may predict up to 75% of difficult intubations.

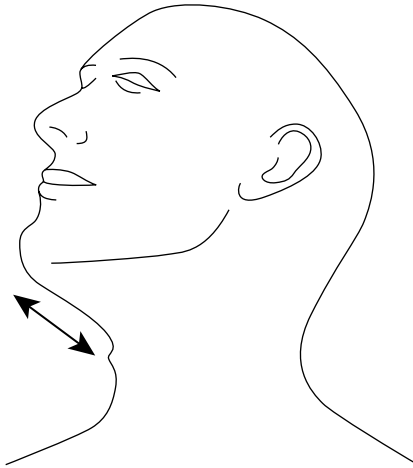

Figure Line shows the thyromental distance from the thyroid cartilage to the tip of the chin.

Sternomental distance

This test is claimed to predict up to 90% of difficult intubations. The distance from the upper border of the manubrium sterni to the tip of the chin, with the mouth closed and the head fully extended, is measured. A distance of less than 12.5 cm indicates a difficult intubation.

Other tests

Indirect laryngoscopy and various x-ray procedures are occasionally used. Using x-ray photographs the effective mandibular length is compared with the posterior depth of the mandible; a ratio of more than 3.6 may be associated with a difficult intubation. A decreased distance between the occiput and the spinous process of C1 is also reported as associated with difficulties with laryngoscopy. We have found these tests to be of limited value.

Conclusion

The airway must be assessed before any anaesthetic procedure is embarked upon. Airway control and endotracheal intubation is occasionally difficult, or even impossible, in anatomically normal people. An assessment from the patient's history, symptoms and medical conditions, combined with careful clinical examination, will help avoid most, but not all, unexpectedly difficult intubations.

Chapter 3 Control of the airway

The novice anaesthetist must learn rapidly the skills of airway control.

Position

The patient must be correctly positioned. This is achieved by elevating the head by about the height of a pillow to flex the neck. The head is extended on the cervical spine and the mandible lifted forward to stop obstruction from the tongue and other pharyngeal structures that lose their tone under anaesthesia. This position is commonly referred to as ‘sniffing the early morning air’ – a practice not to be recommended in a modern urban environment.

Methods

There are four methods of airway control that are used for the purpose of ensuring unobstructed gas exchange (Box).

Box Methods of airway control

- Facemask and Guedel airway
- Laryngeal mask
- Endotracheal tube
- Tracheostomy

Face mask

The mask is designed to fit snugly over the patient’s nose and mouth. However, gas often leaks round the side of the mask in edentulous patients. Clear masks allow you to see the airway and any secretions or vomit. Newer masks have inflatable rims that allow air to be added or removed from the mask to improve the tightness of the seal. An obstructed airway may be relieved by the insertion of an oropharyngeal airway (Guedel airway) or by a nasopharyngeal airway.

Control of the airway

Guedel airways are sized from 0 to 4, with a size 3 used for adult females and 4 for adult males. Nasopharyngeal airways, unless they are inserted very gently, can cause haemorrhage, which may further threaten the airway.

Laryngeal mask

This was developed from the concept that the anaesthetic face mask could, instead of being applied to the face, be altered and positioned over the laryngeal opening (Fig.). It is inserted using a blind technique and provides a patent airway for spontaneous breathing; it is used occasionally for ventilation and management of difficult intubation.

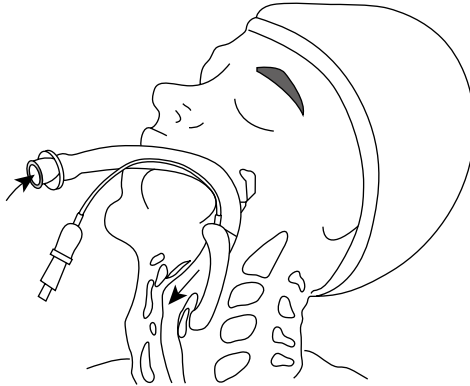

Figure Laryngeal mask correctly positioned before inflation, with the tip of the mask in the base of the hypopharynx.

The original design of laryngeal mask was re-usable after autoclaving. There are now many disposable options available but these are often more difficult to insert. Flexible or non-kinking versions are also used. An oesophageal point is available on some tubes; this is designed to allow vomit to pass directly out of the tube, which in theory, minimises tracheal contamination from the vomit. The experienced anaesthetist can pass a 6.0 mm cuffed endotracheal tube, gum elastic bougie or fibre-optic laryngoscope through the laryngeal mask. A black line is present on the tube that ensures correct orientation of the mask. The sizes are 2 and 2½ for children, 3 for adult females and 4 or 5 for adult males.

The main advantage of this technique is that the anaesthetist has both hands free to undertake other tasks. The laryngeal mask permits the measurement of the oxygen, carbon dioxide and volatile anaesthetic concentration in the expired gas.

10 How to survive in anaesthesia

The mask does *not* prevent gastric aspiration occurring, is not suitable for emergency anaesthesia, and incorrect positioning can occur which may lead to airway obstruction. This is often due to folding back of the epiglottis as it is pushed down by the mask during insertion and occurs in about 10% of patients. An obstructed mask must be removed and repositioned.

Endotracheal tube

A cuffed endotracheal tube, once inserted into the trachea, maintains airway patency and minimises gastric aspiration into the lungs. All endotracheal tubes have information written upon the tube (Fig. 2.2).

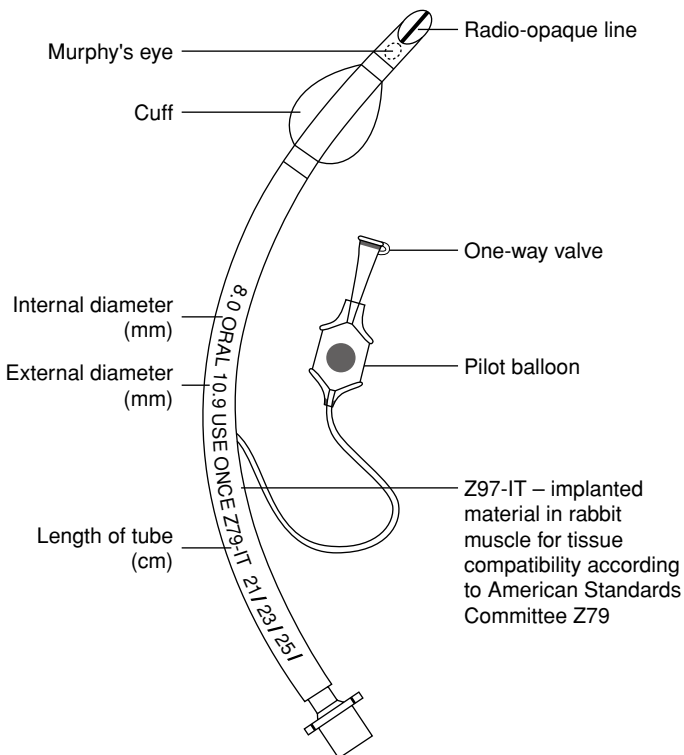

Figure Typical endotracheal tube.

A novice anaesthetist is expected to be able to provide a detailed description of the information on an endotracheal tube: it is a basic tool of the trade! The tube is inserted by holding the laryngoscope in the left hand and passing the

Control of the airway

blade into the right side of the mouth. The tongue is then pushed to the left as the blade is passed down the tongue and inserted anterior to the epiglottis in the vallecula. Elevation of the whole laryngoscope will facilitate a clear view of the glottic opening (Fig. 2.3).

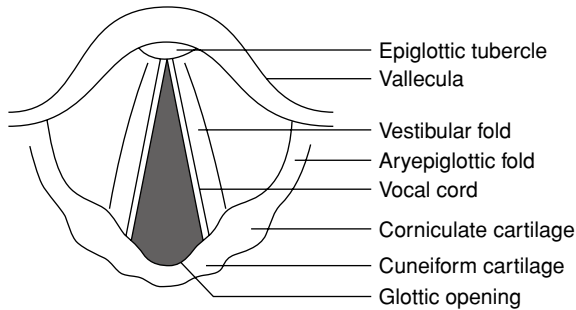

Figure View of the larynx obtained before intubation.

Tips to aid insertion of the endotracheal tube include:

- the use of a gum elastic bougie inserted through the larynx with the tube passed over it
- the application of pressure externally over the larynx to bring it into view
- a 'helping finger' from an assistant to pull the cheek out to allow better vision in the mouth

The timely use of a gum elastic bougie can make endotracheal intubation easier and less traumatic. Occasionally, the tracheal tube impinges on the posterior rim of the larynx and will not pass smoothly over the bougie into the larynx. Rotating the tube 90° anticlockwise prevents this obstruction and facilitates intubation when using a bougie. The general principle of 'a big cannula over a small guidewire' is widely used in medicine. A size 8.0 mm endotracheal tube is used for adult females and 9.0 mm for adult males. This size refers to the *internal* diameter of the tube. Tubes are normally cut to a length of 21–23 cm.

Tracheostomy

Tracheostomy is used for airway control in the following circumstances:

- to bypass upper respiratory tract obstruction
- for long-term ventilation
- to facilitate suction of chest secretions
- for prevention of aspiration of gastric contents (for example, in bulbar palsy)

How to survive in anaesthesia

Percutaneous cricothyroidotomy is occasionally necessary in acute, upper airway obstruction.

Conclusion

Obstruction of the airway must be prevented at all times – a patent airway is a happy airway. Take care of the airway, and inquests will take care of themselves! (BJA 1925).

Chapter 4 Tracheal intubation

Tracheal intubation is an acquired skill. Hypoxia as a result of unrecognised oesophageal intubation can cause death. Intubation can be performed with the patient awake (local anaesthesia) or under general anaesthesia. Intubation can be achieved using the techniques shown in Box .

Intubation techniques

- Above the cords
 - blind intubation
 - nasal
 - using laryngeal mask
 - larynx visualisation
 - oral (\pm gum elastic bougie)
 - laryngeal mask with fibre-optic laryngoscopy
 - fibre-optic laryngoscopy
- Below the cords
 - cricothyroid puncture
 - retrograde intubation
 - cricothyroidotomy
 - transtracheal ventilation
 - tracheostomy

Laryngoscopes

The laryngoscope is an important tool. It is essentially a light source on a tongue retracting blade. Many variations exist but it is always best to use a medium length blade first when attempting intubation. Long blades are often offered by anaesthetic technicians but only rarely needed.

How to survive in anaesthesia

Laryngoscopic views

The laryngoscopic views seen on intubation are often recorded by the anaesthetist and have been graded by Cormack and Lehane.

- Grade I: full view of glottis
- Grade II: only posterior commissure visible
- Grade III: only tip of epiglottis visible
- Grade IV: no glottic structure visible.

Displacement

Tracheal tubes can be displaced after correct insertion. This is particularly likely when the patient is moved or the position changed. Flexion or extension of the head, or lateral neck movement, has been shown to cause movement of the tube of up to 5 cm within the trachea. Tracheal tubes should be fixed securely to minimise accidental extubation and the correct positioning should be checked regularly.

Confirmation of tracheal intubation

Confirmation is by clinical signs and technical tests. In the operating theatre both methods are used; however, elsewhere only clinical signs can be used.

Clinical signs

These are listed in Box .

Box Clinical signs used to confirm tracheal intubation

- Direct visualisation of tracheal tube through vocal cords
- Palpation of tube movement within the trachea
- Chest movements
- Breath sounds
- Reservoir bag compliance and refill
- Condensation of water vapour on clear tracheal tubes

Seeing the tracheal tube passing through the vocal cords is the best clinical method of confirming tracheal intubation. This is normally achieved easily, but is not always possible in technically difficult intubations. All anaesthetists can recount situations where they *think* they have seen the tracheal tube pass through the vocal cords but subsequently found it in the oesophagus. The belief that the trachea is intubated can lead to a false sense of airway security

Tracheal intubation

if cyanosis occurs, and often other causes are sought for the hypoxaemia. The position of the tracheal tube must always be checked in these circumstances.

The other listed signs are helpful, but *unreliable*, in confirming correct placement of the tracheal tube.

Although an assistant applying cricoid pressure may 'feel' the tube passing down the trachea, the same sensation can also occur with an oesophageal intubation. Observation of chest wall movement is no guarantee of correct tracheal tube placement. It may be impossible to observe in some patients (due to obesity) and may occur also in cases of oesophageal intubation.

Auscultation can be misleading: gas movement in the oesophagus can be transmitted to the lungs and so oesophageal sounds may be mistaken for lung sounds. Epigastric auscultation can be undertaken, but breath sounds again may be heard in the epigastrium, and so can cause confusion.

There is a characteristic 'feel' to the breathing circuit reservoir bag, which is often different when the oesophagus is intubated. Reservoir bag refilling will occur in tracheal intubation, but has been described after stomach distension with oesophageal intubation. A 'rumbling' noise is often heard in oesophageal intubation, which is distinct from that heard in tracheal intubation.

Condensation of water vapour is more likely to be seen with tracheal intubation, but can be present in gas emanating from the stomach and so is considered unreliable. If in doubt, and if at all possible, it is worth confirming correct tracheal tube placement by viewing again the tube passing through the larynx.

Technical tests

The commonly used tests are shown in Box .

Box Technical tests to confirm intubation

- Negative pressure tests
- End-tidal CO₂ monitoring – six breaths
- Fenum disposable CO₂ monitors
- Fibre-optic observations of the trachea

Negative pressure tests rely on the fact that there are differences in the rigidity of the tracheal and oesophageal walls. Following intubation, a negative pressure is applied to the tube. Oesophageal walls are muscular and collapse upon application of a negative pressure and aspiration is prevented. Tracheal walls are rigid and, when a negative pressure is applied to the tube, tracheal gas can be aspirated. A negative pressure can be applied by using Wee's

How to survive in anaesthesia

oesophageal detector device (Fig.) which is a catheter mount attached to a 60 ml syringe.

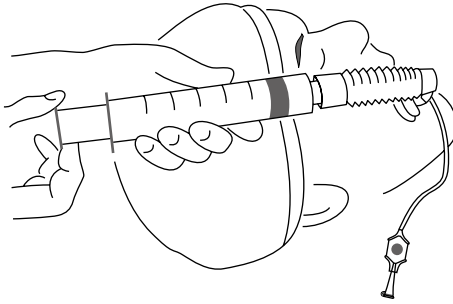

Figure An oesophageal detector.

An emptied, modified Ellick's evacuator bulb can also be attached to the tube and it will reinflate if in the trachea. False-positive results have been reported. It has been found to be impossible to aspirate a tracheal tube because of endobronchial intubation, or obstruction by the wall of the mucosa or by a mucous plug. The end-tidal CO_2 concentration can be measured using a capnograph. If pulmonary perfusion is adequate, end-tidal CO_2 concentration is about 5%. No CO_2 is excreted from the stomach, so any CO_2 present must be from the lungs. *Six breaths of CO_2* must be seen to confirm tracheal intubation. This is because alveolar CO_2 may have been ventilated into the upper gastrointestinal tract before intubation and it will take six breaths to excrete it from the stomach. Carbonated drinks may be present occasionally in the stomach and can cause some confusion. Fenum CO_2 analysers of disposable plastic contain a chemical indicator which changes colour on exposure to CO_2 . These last several hours.

A fibre-optic laryngoscope placed through the endotracheal tube will show if tracheal placement is correct.

Although there are many tests to confirm tracheal intubation, the 'gold standard' is six breaths of end-tidal CO_2 with visual confirmation of laryngeal placement of the tube.

Complications of tracheal intubation

The complications of intubation are shown in Box . The trainee needs to take special care to avoid the immediate complications. Tracheal tubes can easily kink or be placed too far into the trachea and either sit on the carina or pass into the right main bronchus. High airway pressures may be seen when a

Tracheal intubation

Box Complications of tracheal intubation

Laryngoscopy

- trauma to mouth, teeth, pharynx and larynx
- increased arterial pressure
- arrhythmias
- laryngospasm
- bronchospasm

Immediate

- oesophageal placement
- pulmonary aspiration
- displacement of tube from trachea
- endobronchial intubation
- airway obstruction: tube kinked, mucous plug, tracheal cuff herniation over lower end of tube

Long term

- cord ulceration
- tracheal stenosis
- recurrent and superior laryngeal nerve damage

patient is ventilated with these complications. Auscultation of the chest bilaterally may reveal a different intensity of breath sounds in endobronchial intubation. The tube is then pulled back and positioned correctly. Although almost invariably the tracheal tube passes into the right main bronchus, we have managed on rare occasions to intubate the left main bronchus.

Conclusion

The tracheal tube must be correctly sited and secured. Confirmation by direct observation of tracheal placement and six breaths of end-tidal CO₂ with continuous monitoring can avoid the potentially fatal consequences resulting from hypoxia. An anaesthetic maxim to remember when unsure of tracheal tube placement is:

IF IN DOUBT, TAKE IT OUT!

Patients do not die from failure to intubate but from failure to oxygenate.

Chapter 5 Failed intubation drill

It is essential to ask for assistance before anaesthetising patients who have been assessed as having potentially difficult airways. Failed tracheal intubation can occur in both elective and emergency anaesthesia. It is important to prepare a plan of management should intubation be impossible during the induction of general anaesthesia. We recommend that ‘failed intubation drills’ should be practised when juniors are accompanied by senior colleagues.

Initial strategy

The strategy for each case should be similar to that shown below (Box 4.1). Calling for senior help, preventing hypoxia and not giving further doses of muscle relaxants when you are confronted by an impossible intubation are key points.

Box Initial course of action for failed intubation

- 1** Plan a course of management before starting anaesthesia
- 2** Call for *HELP*
- 3** Maintain airway
- 4** Ventilate with 100% oxygen
- 5** Maintain cricoid pressure (if part of anaesthetic technique)
- 6** Avoid persistent attempts to intubate if patient is hypoxic
- 7** Avoid further doses of muscle relaxants unless you are absolutely sure of airway control and ventilation

The airway must be patent and *the patient must be oxygenated*. Suxamethonium is the muscle relaxant with the fastest onset and is always used for emergency surgery, in patients with full stomachs, and in those who are at risk of regurgitation (for example, hiatus hernia). Experienced anaesthetists often use muscle relaxants of slower onset for elective surgical patients in

Failed intubation drill

whom they can be confident of airway control. Muscle relaxants should *not* be given inappropriately, for example in cases of upper airway obstruction. If a patient is paralysed, and tracheal intubation, patency of the upper airway, and oxygenation are impossible, then hypoxaemia and death will occur.

Consider why intubation has failed. A common cause in emergency anaesthesia is inexpertly applied cricoid pressure. In these circumstances the larynx may need to be manipulated into view. A gum elastic bougie is helpful for railroading tracheal tubes into position when the larynx is visible but the tube will not pass into the trachea. Do not spend time attempting these manoeuvres if the patient is becoming hypoxic.

Secondary decisions

If intubation has failed, further decisions have to be made (Box).

Box Subsequent decisions for consideration after failed intubation

- 1** Awaken patient or continue anaesthetic until senior help arrives
- 2** Summon experienced help – intubate under general or local anaesthesia: laryngeal mask (intubation through mask), fibre-optic intubation, blind nasal intubation
- 3** Last resorts include retrograde intubation, transtracheal jet ventilation, cricothyroidotomy
- 4** Make elective tracheostomy
- 5** Perform surgery under regional anaesthesia

The safest decision is to awaken the patient, although this may be modified by considering the elective or emergency nature of the surgery. Patients are not usually pleased to be woken up without undergoing surgery, but at least they are alive to complain! If airway control and ventilation are easy, or the patient reverts spontaneously to breathing in an unobstructed fashion and help is nearby, the anaesthetic may be continued. A laryngeal mask can secure airway patency when other methods have failed. Sometimes it is possible to continue the anaesthetic with the patient breathing spontaneously unintubated, but intubation may be mandatory.

Intubation can be achieved through a laryngeal mask airway, by blind nasal intubation techniques or via a fibre-optic laryngoscope. Retrograde intubation can also be used occasionally. This technique involves cricothyroid membrane puncture and a guide catheter being pushed up through the larynx and out of the mouth. A tracheal tube can then be passed over the

How to survive in anaesthesia

guiding catheter (the same principle as described in Chapter). Equipment for achieving airway control includes cricothyroid puncture devices that can be connected to a breathing circuit and transtracheal jet ventilation devices.

Formal tracheostomy may have to be considered. Abandonment of a general anaesthetic technique and implementation of surgery under a regional analgesia is a sensible alternative.

After failed intubation, both the patient and other anaesthetists need to be informed of the difficulty in the case of surgery at a later date. Therefore:

- 1 Note grade of intubation
- 2 Mark patient's notes boldly
- 3 Inform patient verbally and by letter

The patient's folder containing the clinical records should be marked stating the anaesthetic problem.

Conclusion

Failed intubation should be prepared for and the priority initially should be on airway control and ventilation of the lungs. It is usually safer to awaken a patient and then consider the alternatives after consultation with a more experienced colleague.

A 'failed intubation drill' should be committed to memory very early in the training programme and be practised at regular intervals. Sooner or later it will be needed.

Remember, the objective after failed intubation is oxygenation, oxygenation, followed by **OXYGENATION**.

Chapter 6 Vascular access

Vascular access may be classified into venous (peripheral, central) and arterial. Peripheral venous cannulation is easier to gain expertise even by a novice anaesthetist. It is also important to become proficient in central venous cannulation and insertion of arterial cannulae, within the first few months of training. We have not included detailed practical descriptions on how to undertake these procedures; these skills are best learnt by careful instruction from a senior anaesthetist.

Peripheral venous access

No general or regional anaesthetic procedure should start without intravenous access. A large bore cannula (14 or 16 gauge) or occasionally a small cannula (21 or 23 gauge) may be used, depending on the type of surgery. Flows through peripherally placed cannulae can be surprisingly high (Table).

Table Flow rates through typical venous cannulae

Peripheral		Central	
Gauge	Flow (ml/min)	Gauge	Flow (ml/min)
23	16		
21	21		
18.5	48		
16	121	16	110
14	251	14	230

For any surgical procedure in which rapid blood loss may occur, nothing smaller than a 16 gauge cannula should be used. For major surgery at least one 14 gauge cannula is essential. The major determinant of the flow rate achieved through a cannula is the fourth power of the internal radius. All large-bore intravenous cannulae that are inserted before induction of anaesthesia should

How to survive in anaesthesia

be placed after the intradermal infiltration of lignocaine using a 25 gauge needle. The 'sting' of the local anaesthetic is trivial compared with the pain of a large intravenous cannula pushed through the skin – we speak from bitter personal experience. Be kind to your patients.

Central venous access

Central venous cannulation is undertaken to provide venous access when the peripheral route is unavailable, to measure central venous pressure, to administer drugs, and to provide parenteral nutrition.

There are two main routes by which anaesthetists acquire central venous access. First, a long venous catheter may be inserted via the basilic vein in the antecubital fossa, which will pass, one hopes, into the superior vena cava. The final position of the catheter needs confirmation by x-ray films, as the catheter can pass up into the internal jugular vein and even down the other arm. There are few complications with this technique, although 'damped' pressure recordings are often seen with long catheters, and enthusiastic insertion occasionally results in the measurement of right ventricular pressures!

Second, a technique involving cannulation of the internal jugular vein is used. The internal jugular vein arises as a continuation of the sigmoid sinus as it passes through the jugular foramen. It lies within the carotid sheath, lateral to the carotid artery and the vagus nerve, and runs beneath the sternal and clavicular heads of the sternomastoid muscle where it can be 'palpated'. It finally passes under the medial border of the clavicle to join the subclavian vein.

The right internal jugular vein is normally used as the veins are relatively straight on the right side of the neck and the thoracic duct is avoided. A strict aseptic technique with the patient in a head-down position is used. This fills the veins and avoids the risk of air embolism. A 'high-neck' approach lessens the complications and the cannula can be inserted after ballotting the vein, or lateral to the carotid arterial pulsation. Some anaesthetists find it difficult to palpate the internal jugular vein, but it is often felt as the boggiest part of the neck lateral to the carotid artery. If the patient is hypovolaemic it can be impossible to ballote the vein.

Although internal jugular vein cannulation is relatively safe in skilful hands, problems can occur (Box).

Haematomas are the most common, and we have been impressed by the lack of problems following inadvertent carotid artery puncture. Pneumothorax should not occur with the 'high-neck' approach. If you have more than 4 cm of the cannula inserted and still have not found the vein, stop and try a different site.

Box Complications of internal jugular vein catheterisation

- Immediate
 - venous haematoma
 - carotid artery puncture haematoma
 - pneumothorax
 - haemothorax
 - nerve trauma (brachial plexus, vagus, phrenic)
 - air embolism
- Delayed
 - infection

Central venous pressure is measured from the midaxillary line via a pressure transducer or a water manometer. There is no normal central venous pressure. It is the response to an intravenous fluid load that determines whether the patient is hypovolaemic or not. The causes of variants in central venous pressure are shown in Box .

Box Variants in central venous pressure

- Low pressure
 - hypovolaemia
 - respiratory phase variation
- High pressure
 - hypervolaemia
 - right ventricular dysfunction
 - increased right ventricular afterload
 - pulmonary hypertension
 - parenchymal pulmonary disease
 - pneumothorax
 - haemothorax
 - left heart failure
 - atrial arrhythmias
 - tricuspid valve disease

Arterial access

This is commonly performed via the radial artery with a 20 or 22 gauge cannula. An Allen's test may be done to assess the relative contributions of the radial and ulnar arteries to blood flow of the hand. This is done by occluding

How to survive in anaesthesia

both the radial and ulnar arteries and then watching for 'palmar flushing' when the ulnar artery is released. If flushing occurs, then it implies that, in the event of radial artery trauma or occlusion, the ulnar artery will supply the hand. In practice, we never bother with Allen's test as its value is not proven. Complications of arterial cannulation include thrombosis, infection, fistula, aneurysm, and distal ischaemia. These are rare but, in the event of clinical ischaemia, the cannula should be removed and expert help sought urgently. Colour coding of arterial cannulae and their dedicated infusion tubing with red tags and red three-way taps should be undertaken if possible. This reduces the risk of inadvertent injection of drugs into arteries. We have seen the results of such accidents – gangrenous fingers are most unpleasant.

Conclusion

Intravenous access is mandatory before starting any form of anaesthesia, local or general. If there is *any* possibility of rapid blood loss, insert a large bore intravenous cannula. Lack of vascular access is a major contributor to anaesthetic disasters.

Chapter 7 Intravenous Fluid

Intravenous fluids and electrolytes are administered, often empirically, to replace or maintain the body's own requirements. Patients are starved preoperatively to ensure an empty stomach. There is much debate on how long a patient should be without fluids or food before elective surgery: 4–6 hours is often taken as the minimum requirement for food and 2–4 hours for clear fluids, but many patients starve overnight for at least 12 hours before anaesthesia.

Once you have inserted an intravenous cannula, it is necessary to give an appropriate fluid. The main choice is between crystalloid or colloid solutions. There are also glucose-containing solutions but it is difficult to make a case for continued use of such solutions. There is considerable debate on the relative merits of crystalloid or colloid solutions. In practice, most anaesthetists start with 1–2 litres crystalloid and follow this with a similar volume of colloid solution in major surgery.

Fluids are given intraoperatively to:

- replace existing deficits
- maintain fluid balance
- replace surgical loss

The existing fluid deficit can be high, particularly in bowel surgery where enemas are used and with prolonged starvation in a warm environment; 1 litre of crystalloid given intravenously at the start of anaesthesia often only replaces an existing deficit.

The rate of fluid replace with infusion is determined by assessing the adequacy of the circulating blood volume using the following indices:

- arterial pressure
- heart rate
- central venous pressure (if available)

How to survive in anaesthesia

- urine output
- peripheral temperature (if available)

Crystalloids

Crystalloids are isotonic solutions that have a similar fluid and electrolyte composition to the extracellular fluid. These solutions are confined to the extracellular space in a ratio of 1:3 in terms of intravascular: interstitial volume. The two commonly available solutions are Hartmann's solution and 0.9% sodium chloride solution. The lactate in Hartmann's solution is either oxidised in the liver, or undergoes gluconeogenesis. Both metabolic pathways use hydrogen ions so that mild alkalinisation occurs. It is important to remember that both these solutions add little to the intravascular volume.

Glucose-containing solutions

It is difficult to make a case for continuing the use these solutions. The stress of surgery increases circulating blood glucose so that the addition of more glucose intravenously exacerbates the metabolic insult. Furthermore, when glucose is eventually oxidised to water and carbon dioxide, the infusion is then equivalent to water (5% glucose) or a very weak hypotonic solution (4% glucose + 0.18% sodium chloride solution). The main reason for continuing the use these solutions seems to be the fear of the phase of sodium retention that inevitably accompanies surgery. Since low plasma sodium concentrations are almost invariably found postoperatively, this fear is unsubstantiated – patients usually need more sodium. Only a small proportion of glucose-containing solutions stay within the intravascular space; they are of little value in maintaining the blood volume.

The composition of commonly used intravenous fluids is shown in Table 6.1.

Table Electrolytic composition of intravenous solutions (mmol/l)

Solution	Na	K	Ca	Cl	Lactate
0.9% Sodium chloride	150	–	–	150	–
Hartmann's solution	131	5	2	111	29
5% Glucose	–	–	–	–	–
4% Glucose in 0.18% NaCl	30	–	–	30	–
Gelofusine	154	–	–	125	–
Haemaccel	145	5	6	145	–
Hydroxyethyl starch	154	–	–	154	–

Colloids

These are large molecules suspended in solution. They generate a colloid osmotic pressure and are confined to the intravascular space. They rarely cause allergic reactions as a side effect. Elimination is via the kidneys. There are two main types in clinical practice:

- modified gelatins
- hydroxyethyl starch

The modified gelatins are 'Haemaccel' (polygeline) and 'Gelifusine' (succinylated gelatin). The electrolytic composition and properties are shown in Tables 6.1 and 6.2, respectively, the properties being compared with albumin.

Table Properties of colloid solutions

	MW	Plasma $t_{1/2}$ (h)	Elimination	Anaphylaxis
Albumin	69,000	24	Slow	Nil
Haemaccel	35,000	3	Rapid	Rare
Gelifusine	30,000	3	Rapid	Rare
Hydroxyethyl starch	450,000	6–9	Slow	Rare

Haemaccel contains calcium, which can cause clotting in an intravenous infusion set when it becomes mixed with citrated blood and plasma.

Hydroxyethyl starch is taken up by the reticuloendothelial system after phagocytosis in the blood, and this results in its prolonged degradation and elimination. The maximum dose is limited to 20 ml/kg/day.

Conclusion

Fluid therapy is simple. Start with 1–2 litres crystalloid solution (Hartmann's solution or 0.9% sodium chloride) and follow this, if necessary, with a suitable colloid solution. Do not use glucose-containing solutions without a good reason and, if there is marked blood loss, consider red cell replacement (see Chapter).

chapter 8 Pharmacology of Intravenous and Inhalation Anesthetics

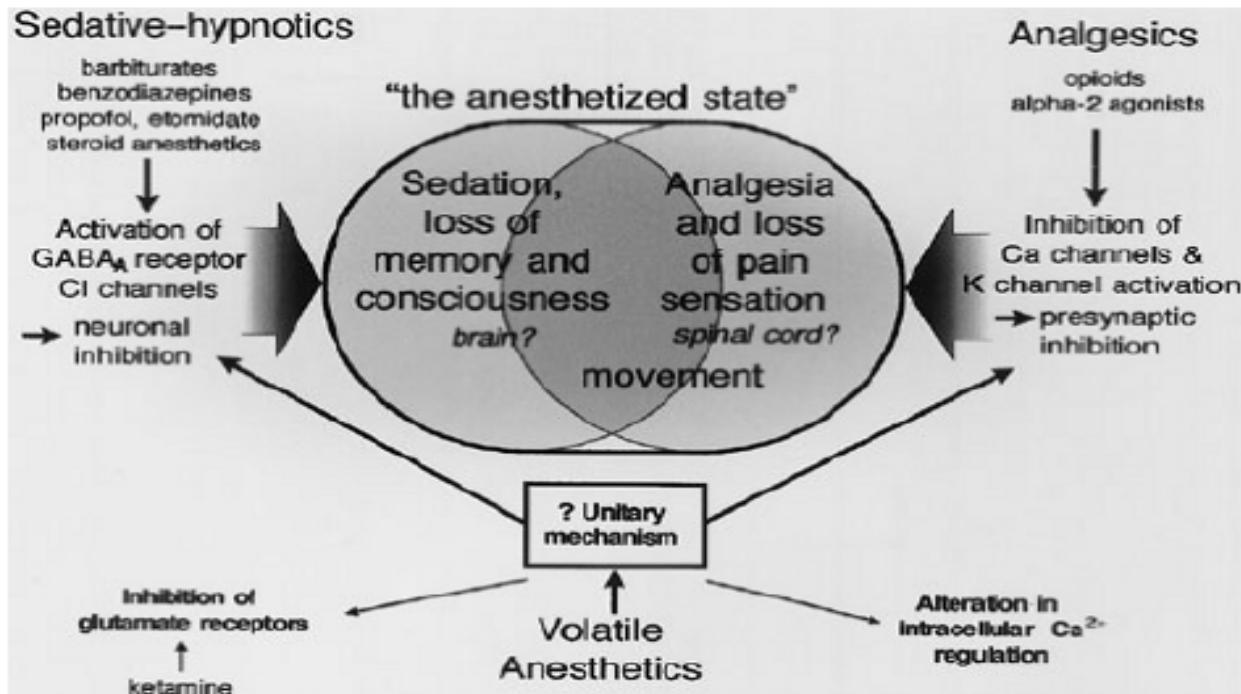

I. Pharmacology of intravenous (IV) anesthetics.

IV anesthetics are commonly used for induction of general anesthesia, maintenance of general anesthesia, and sedation during local or regional anesthesia.

Propofol (2,6-diisopropylphenol) is used for induction or maintenance of general anesthesia as well as for conscious sedation.

- It is prepared as a 1% isotonic oil-in-water emulsion, which contains egg lecithin, glycerol, and soybean oil.
- Mode of action: Increases activity at inhibitory gamma-aminobutyric acid (GABA) synapses. Inhibition of glutamate (N-methyl-D-aspartate [NMDA]) receptors may play a role.
- Pharmacodynamics
 - Central nervous system (CNS)
 - Induction doses rapidly produce unconsciousness (30 to 45 seconds), followed by rapid reawakening due to redistribution. Low doses produce sedation.
 - Weak analgesic effects at hypnotic concentrations.
 - Decreases intracranial pressure (ICP) but also cerebral perfusion pressure.
 - Cardiovascular system
 - Dose-dependent decrease in preload and afterload and depression of contractility leading to decreases in arterial pressure and cardiac output.
 - Heart rate is minimally affected, and baroreceptor reflex is blunted.
 - Respiratory system

- Produces a dose-dependent decrease in respiratory rate and tidal volume.
 - Ventilatory response to hypercarbia is diminished.
- Other effect

May cause pain during IV administration in as many as 50% to 75% of patients. Pain may be reduced by administering IV in a large vein or by adding lidocaine to the solution.

Barbiturates for anesthesia include thiopental and methohexital. These medications, like propofol, rapidly produce unconsciousness (30 to 45 seconds), followed by rapid reawakening due to redistribution.

- Mode of action: Barbiturates occupy receptors adjacent to GABA receptors in the CNS and augment the inhibitory tone of GABA.
- Pharmacodynamics
- CNS
 - Produce unconsciousness and suppress responses to pain at much higher concentrations.
 - Thiopental can cause hyperalgesia at subhypnotic concentrations (clinical relevance uncertain).
 - Produce a dose-dependent cerebral vasoconstriction and decrease in cerebral metabolism which decrease cerebral blood flow and intracranial pressure.
- Cardiovascular system
 - Cause venodilation and depress myocardial contractility, so arterial blood pressure and cardiac output decrease in a dose-dependent manner, especially in patients who are preload dependent.
 - May increase heart rate. Very little effect on baroreceptor reflexes.
- Respiratory system
 - Produce a dose-dependent decrease in respiratory rate and tidal volume. Apnea may result for 30 to 90 seconds after an induction dose.
 - Laryngeal reflexes more active than with propofol. Incidence of laryngospasm is higher.
- Adverse effects
 - Allergy. True allergies are unusual. Thiopental occasionally causes anaphylactoid reactions (hives, facial edema, hypotension).
 - Porphyria
 - Absolutely contraindicated in patients with acute intermittent porphyria, variegate porphyria, and hereditary coproporphyria.
- Venous irritation and tissue damage
 - May cause pain at the site of administration because of venous irritation.
 - Subcutaneous infiltration or intra-arterial administration of thiopental (but not methohexital) may cause severe pain, tissue damage, arterial spasm, and necrosis. If intra-arterial administration occurs, heparin treatment, vasodilators, and/or regional sympathetic blockade may be helpful in treatment.

Benzodiazepines include Midazolam, Diazepam, and Lorazepam. They are often used for sedation and amnesia or as adjuncts to general anesthesia.

- **Mode of action:** Enhance the inhibitory tone of GABA receptors.
- Pharmacodynamics
 - CNS
 - Produce amnestic, anticonvulsant, anxiolytic, muscle-relaxant, and sedative-hypnotic effects in a dose-dependent manner.
 - Do not produce significant analgesia.
 - Reduce cerebral blood flow and metabolic rate.
 - Cardiovascular system
 - Produce a mild systemic vasodilation and reduction in cardiac output. Heart rate is usually unchanged.

- Hemodynamic changes may be pronounced in hypovolemic patients or in those with little cardiovascular reserve if rapidly administered in a large dose or if administered with an opioid.
 - Respiratory system
 - Produce a mild dose-dependent decrease in respiratory rate and tidal volume.
 - Respiratory depression may be pronounced if administered with an opioid, in patients with pulmonary disease, or in debilitated patients.
- Dosage and administration: for midazolam.
 - Incremental IV doses of diazepam (2.5 mg) or lorazepam (0.25 mg) may be used for sedation. Appropriate oral doses are 5 to 10 mg of diazepam or 2 to 4 mg of lorazepam.
- Adverse effects
 - Drug interactions. Administration of a benzodiazepine to a patient receiving the anticonvulsant valproate may precipitate a psychotic episode.
 - Pregnancy and labor
 - May be associated with birth defects (cleft lip and palate) when administered during the first trimester.
 - Cross the placenta and may lead to a depressed neonate.
 - Superficial thrombophlebitis and injection pain may be produced by the vehicles in diazepam and lorazepam.
- Flumazenil is a competitive antagonist for benzodiazepine receptors in the CNS.
 - Reversal of benzodiazepine-induced sedative effects occurs within 2 min; peak effects occur at approximately 10 min. Flumazenil does not completely antagonize the respiratory depressant effects of benzodiazepines.
 - Flumazenil is shorter acting than the benzodiazepines it is used to antagonize. Repeated administration may be necessary because of its short duration of action.
 - Dose: 0.3 mg IV every 30 to 60 seconds (to a maximum dose of 5 mg).
 - Flumazenil is contraindicated in patients with tricyclic antidepressant overdose and in those receiving benzodiazepines for control of seizures or elevated intracranial pressure.

Ketamine is a congener of phencyclidine. It is a sedative-hypnotic agent with powerful analgesic properties. Usually used as an induction agent.

- Mode of action: Not well defined but includes antagonism at the NMDA receptor.
- Produces unconsciousness in 30 to 60 seconds after an IV induction dose. Effects are terminated by redistribution in 15 to 20 min. After intramuscular (IM) administration, the onset of CNS effects is delayed for approximately 5 min, with peak effect at approximately 15 min.
 - CNS
 - Produces a dissociative state accompanied by amnesia and analgesia. Analgesia occurs at much lower concentrations than hypnosis, so analgesic effects persist after awakening.
 - Increases cerebral blood flow (CBF), metabolic rate, and intracranial pressure. CBF response to hyperventilation is not blocked.
 - Cardiovascular system
 - Increases heart rate as well as systemic and pulmonary artery blood pressures by causing centrally mediated release of endogenous catecholamines.
 - Often used to induce general anesthesia in hemodynamically compromised patients, particularly those for whom heart rate, preload and afterload, should remain high.
 - Respiratory system
 - Usually depresses respiratory rate and tidal volume only mildly and has minimal effect on CO₂ response.
 - Alleviates bronchospasm by a sympathomimetic effect.
 - Laryngeal protective reflexes are relatively well-maintained, but aspiration can still occur.
- Dosage and administration:
 - Ketamine may be especially useful for IM induction in patients in whom IV access is not available (e.g., children). Ketamine is water soluble and may be administered either IV or IM.
 - A concentrated 10% solution is available for IM use only.
- Adverse effects

- Oral secretions are markedly stimulated by ketamine.
- Emotional disturbance.
- Muscle tone is often increased.
- Increases intracranial pressure and is relatively contraindicated in patients with head trauma or intracranial hypertension.
- Ocular effects. May lead to mydriasis, nystagmus, diplopia, blepharospasm, and increased intraocular pressure; alternatives should be considered during ophthalmologic surgery.

Opioids.

Morphine, Meperidine, Hydromorphone, Fentanyl, Sufentanil, Alfentanil, And Remifentanil are the opioids commonly used in general anesthesia. Their primary effect is analgesia, and therefore they are used to supplement other agents during induction or maintenance of general anesthesia.

- Mode of action: Opioids bind at specific receptors in the brain, spinal cord, and on peripheral neurons. The opioids listed above are all relatively selective for μ opioid receptors.
- Pharmacodynamics
 - CNS
 - Produce sedation and analgesia in a dose-dependent manner; euphoria is common.
 - Cardiovascular system
 - Produce bradycardia in a dose-dependent manner by stimulation of the central vagal nuclei. Meperidine has a weak atropine-like effect and does not cause bradycardia.
 - The relative hemodynamic stability offered by opioids often leads to their use in sedation or anesthesia for hemodynamically compromised or critically ill patients.
 - Respiratory system
 - Produce respiratory depression in a dose-dependent manner.
 - Pupil size is decreased (miosis) by stimulation of the Edinger-Westphal nucleus of the oculomotor nerve.
 - Nausea and vomiting can occur because of direct stimulation of the chemoreceptor trigger zone. Nausea is more likely if the patient is moving.
 - Urinary retention may occur because of increased tone in the vesical sphincter and inhibition of the detrusor (voiding) reflex. May also decrease awareness of the need to urinate.
- Naloxone is a pure opioid antagonist used to reverse unanticipated or undesired opioid-induced effects such as respiratory or CNS depression.
 - Peak effects are seen within 1 to 2 min; a significant decrease in its clinical effects occurs after 30 min because of redistribution.
 - Metabolized in the liver.
- Dosage and administration: Perioperative respiratory depression in an adult can be treated with 0.04 mg IV every 2 to 3 min as needed.

II. Pharmacology of inhalation anesthetics.

Inhalation anesthetics are usually administered for maintenance of general anesthesia but also can be used for induction, especially in pediatric patients. Dosages of inhalation anesthetics are expressed as MAC, the minimum alveolar concentration at one atmosphere at which 50% of patients do not move in response to a surgical stimulus.

- Mode of action
 - Volatile anesthetics. Exact mechanisms are unknown. Various ion channels in the CNS (including GABA, glycine, and NMDA receptors) have been shown to be sensitive to inhalation anesthetics and may play a role.
 - Volatile anesthetics
 - Elimination
 - Exhalation.

- Metabolism. Volatile anesthetics may undergo different degrees of hepatic metabolism (**Halothane, 15%; Enflurane, 2% To 5%; Sevoflurane, 1.5%; Isoflurane, <0.2%; Desflurane, <0.2%.**)
- Volatile anesthetics effects:
 - CNS
 - Produce unconsciousness and amnesia at relatively low inspired concentrations (25% MAC).
 - Produce a dose-dependent generalized CNS depression and depression of electroencephalographic activity up to and including burst suppression..
 - Increase CBF (halothane > enflurane > isoflurane, desflurane, or sevoflurane).
 - Decrease cerebral metabolic rate (isoflurane, desflurane, or sevoflurane > enflurane > halothane)..
 - Cardiovascular system
 - Produce dose-dependent myocardial depression (halothane > enflurane > isoflurane (desflurane or sevoflurane) and systemic vasodilation (isoflurane > desflurane or sevoflurane > enflurane > halothane).
 - Heart rate tends to be unchanged.
 - Respiratory system
 - Produce dose-dependent respiratory depression with a decrease in tidal volume, an increase in respiratory rate, and an increase in arterial CO₂ pressure.
 - Produce airway irritation (desflurane > isoflurane > enflurane > halothane > sevoflurane) and, during light levels of anesthesia, may precipitate coughing, laryngospasm, or bronchospasm, particularly in patients who smoke or have asthma. The lower pungency of sevoflurane and halothane may make them more suitable as inhalation induction agents.
 - Liver. May cause a decrease in hepatic perfusion (halothane > enflurane > isoflurane, desflurane, or sevoflurane). Rarely, a patient may develop hepatitis secondary to exposure to a volatile agent, most notably halothane
 - Renal system. Decrease renal blood flow through either a decrease in mean arterial blood pressure or an increase in renal vascular resistance.

Pharmacology of Neuromuscular Blockade

The principal pharmacologic effect of neuromuscular blocking drugs (NMBDs) is to interrupt transmission of synaptic signaling at the neuromuscular junction (NMJ) by antagonism of the nicotinic acetylcholine receptor (AChR).

I. Anatomy and physiology of the NMJ

- The NMJ comprises portions of three cell types: motor neuron, muscle fiber, and Schwann cell. It is a chemical synapse located in the peripheral nervous system that is composed of the neuronal presynaptic terminal, where acetylcholine (ACh) is stored and released, and the postsynaptic muscle cell (motor endplate), where high densities of the AChR reside. In the nerve terminal, ACh is stored for eventual release in specialized organelles known as synaptic vesicles.
- After triggering depolarization, the ACh diffuses into the synaptic cleft where it is broken down by acetylcholinesterase (AChE) into choline and acetyl CoA. These molecules are then recycled to synthesize new ACh for use in synaptic vesicles and synaptic transmission.

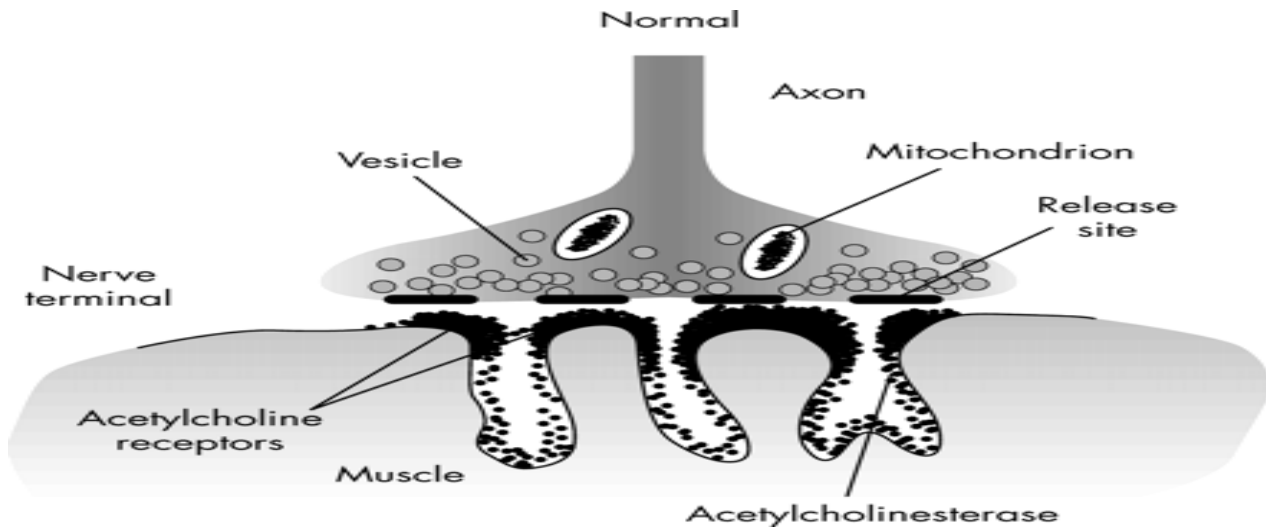

II. General pharmacology of the NMJ

- All NMBDs are antagonists of the AChR. Each is designated depolarizing or nondepolarizing based on whether it induces a depolarization of the muscle membrane after binding to the receptor. The agents differ substantially in their onset, duration of blockade, metabolism, side effects, and interactions with other drugs.
- Succinylcholine (SCh) is currently the only available depolarizing NMBD.
- Nondepolarizing NMBDs are often divided by chemical class: aminosteroid derivatives (e.g., pancuronium, vecuronium, and rocuronium) and benzylisoquinolines (e.g., d-tubocurarine, cisatracurium, and mivacurium). The NMBDs also are commonly classified by duration of effect: ultrashort (SCh), short (mivacurium), intermediate (vecuronium, rocuronium, cisatracurium), and long (pancuronium, d-tubocurarine).

III. Neuromuscular blockade

Depolarizing blockade occurs when a drug mimics the action of the neurotransmitter ACh. SCh, like ACh, binds and activates the AChR, which leads to depolarization of the endplate and adjacent muscle membrane.

Depolarizing blockade from SCh ends when the molecule diffuses away from the receptor and is broken down to choline and succinic acid in the plasma. SCh is hydrolyzed by plasma cholinesterase (also called butyrylcholinesterase or pseudocholinesterase) to choline and succinic acid. This enzyme is not the same as AChE and is not found in the synaptic cleft. Inhibitors of AChE tend to affect both enzymes, however.

- Side effects of SCh are related to its transient agonist effects at both the nicotinic and muscarinic AChRs:
 - Myalgias may occur secondary to muscle fasciculations.

- Arrhythmias, bradycardia, junctional rhythm, and sinus arrest in children after the first dose and in adults receiving a second dose within a short dose interval (i.e., 5 minutes). Pretreatment with atropine (0.4 mg IV) immediately before SCh blocks this bradycardia.
- SCh normally causes serum K^+ to increase 0.5 to 1.0 mEq/L but dangerous hyperkalemia and cardiovascular collapse have occurred in patients with burns, upper and lower motor neuron disease, and injuries. It is advisable to avoid SCh in burned patients after the first 24 hours and for 2 years from the injury. Patients with renal failure may safely receive SCh if they are not currently hyperkalemic or acidemic.
- A transient increase in intraocular pressure due to fascicular contractions of the extraocular muscles.
- Increased intragastric pressure results from fasciculation of abdominal muscles.
- SCh produces a mild brief increase in cerebral blood flow and intracranial pressure.
- A history of malignant hyperthermia is an absolute contraindication to the use of SCh.
- Prolonged blockade may be caused by low levels of plasma cholinesterase,

Nondepolarizing blockade is most commonly due to reversible competitive antagonism of ACh at the alpha subunits of the AChR.

- The clinical pharmacology of the commonly used nondepolarizing NMBDs:
 - Cisatracurium is 1 of 10 stereoisomers that constitute atracurium. It is two to three times as potent as atracurium. Unlike atracurium, it does not produce histamine release or hemodynamic effects after rapid injection of doses as high as eight times its 95% effective dose (ED_{95}).
 - Rocuronium, at a dose of 0.6 mg/kg, good to excellent intubating conditions occur by 60 seconds. It is often chosen when rapid sequence induction is necessary and SCh is contraindicated.
 - Clinical choice of NMBD: Many factors must be considered simultaneously when selecting a NMBD:
 - The urgency for tracheal intubation,
 - The duration of the procedure,
 - Coexisting medical conditions that may affect the NMJ,
 - Side effects and metabolism of the drug.

IV. Monitoring neuromuscular function

Monitoring neuromuscular function

- There are several reasons to monitor neuromuscular function under anesthesia:
 - To facilitate timing of intubation.
 - To provide an objective measurement of relaxation during surgery and degree of recovery before extubation.
 - To titrate dosage according to patient response.
 - To monitor for the development of phase II block.
 - To permit early recognition of patients with abnormal plasma cholinesterase activity.
- Peripheral nerve stimulators use various patterns of stimulation: single-twitch, tetanus, TOF (Train of four).

V. Reversal of neuromuscular blockade

- Recovery from SCh-induced depolarizing blockade usually occurs in 10 to 15 min. Patients with atypical or inhibited plasma cholinesterase will have a greatly prolonged duration of blockade.
- Nondepolarizing block spontaneously recovers when the drugs diffuse from their sites of action. Reversal can be accelerated by administering agents that inhibit AChE (anticholinesterases), thereby increasing the ACh available to compete for binding sites.
- AChEs: The three principal drugs are edrophonium, neostigmine, and pyridostigmine

- Simultaneous administration of atropine or glycopyrrolate is necessary to decrease cholinergic side effects by causing muscarinic receptor blockade.

Pharmacology of Local Anesthetics (e.g. Lidocaine, Bupivacaine etc...)

Definition and Mode of Action

- LA are drugs that block the generation and propagation of impulses in excitable tissues: nerves, skeletal muscle, cardiac muscle, brain
- LA substances bind to a Na⁺ channel receptor on the cytosolic side of the Na⁺ channel (i.e. must be lipid soluble), inhibiting Na⁺ flux and thus blocking impulse conduction
- LA must convert to an ionized form to properly bind to receptor
- Different types of nerve fibres undergo blockade at different rates (see Regional Anesthesia section)

Absorption, Distribution, Metabolism

- LA readily crosses the blood-brain barrier (BBB) once absorbed into the blood stream
- Ester-type LA (**Procaine, Tetracaine**) broken down by plasma and hepatic esterases; metabolites excreted via kidneys
- Amide-type LA (**Lidocaine, Bupivacaine**) broken down by hepatic mixed function oxidases (P450 system); metabolites excreted via kidney

Selection of LA

- Delivery modalities include epidural, spinal, peripheral nerve blockades, local injections, topical
- Choice of LA depends on:
 - Onset of action –influenced by pKa (lower the pKa, the higher the concentration of the base form of the LA and the faster the onset of action)
 - Duration of desired effects – influenced by protein binding (long duration of action when the protein binding of LA is strong)
 - Potency – influenced by lipid solubility (agents with high lipid solubility will penetrate the nerve membrane more easily)
 - Unique needs (e.g. sensory blockade with relative preservation of motor function, for pain management)
 - Potential for toxicity

Maximum Doses for LA

- Always be aware of the maximum dose for the particular LA used
- Maximum dose usually expressed as (mg of LA) per (kg of lean body weight) and as a total maximal dose (adjusted for young/elderly/ill)
 - **Lidocaine** maximum dose: 5 mg/kg (with epinephrine: 7mg/kg)
 - **Chlorprocaine** maximum dose: 11 mg/kg (with epinephrine: 14 mg/kg)
 - **Bupivacaine** maximum dose: 2.5 mg/kg (with epinephrine: 3 mg/kg)

Systemic Toxicity

- Occurs by accidental intravascular injection, LA overdose, or unexpectedly rapid absorption
- Systemic toxicity manifests itself mainly at CNS and CVS
- CNS effects first appear to be excitatory due to initial block of inhibitory fibres; subsequently, block of excitatory fibres
- CNS effects (in approximate order of appearance)
- Numbness of tongue, perioral tingling, disorientation, drowsiness
 - Tinnitus
 - Visual disturbances
 - Muscle twitching, tremors
 - Convulsions, seizures

- Generalized CNS depression, coma, respiratory arrest
- CVS effects
 - Vasodilatation, hypotension
 - Decreased myocardial contractility
 - Dose-dependent delay in cardiac impulse transmission
 - Prolonged PR, QRS intervals
 - Sinus bradycardia
 - CVS collapse

Treatment of systemic toxicity

- Early recognition of signs
- 100% O₂, manage ABCs
- Diazepam may be used to increase seizure threshold
- If the seizures are not controlled by diazepam, consider using:
 - Thiopental, Possible ETT.

Treatment of local anaesthetic intoxication

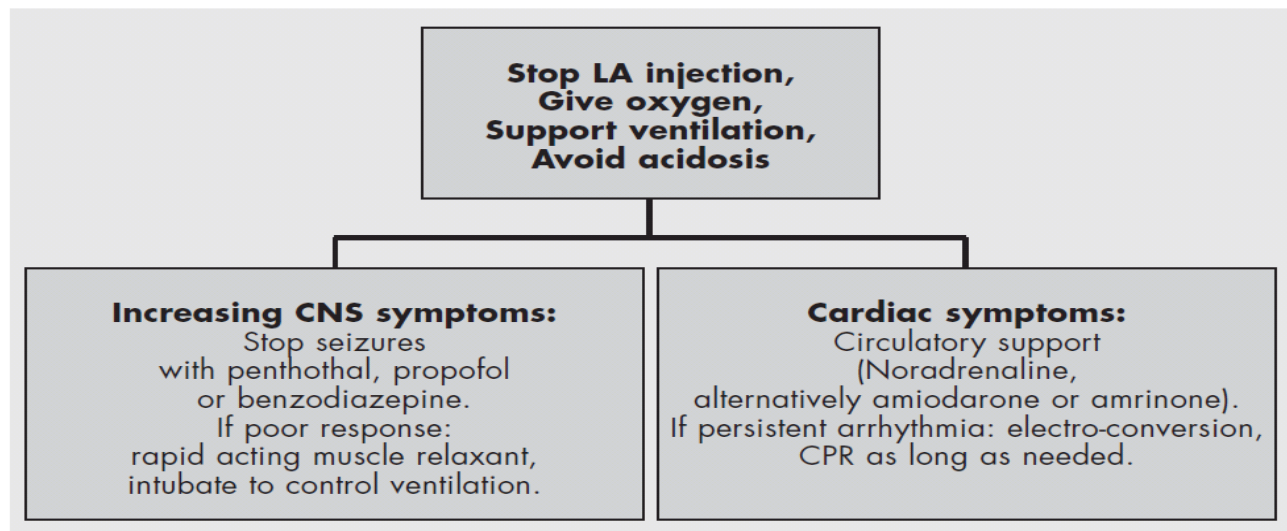

Symptoms and signs of local anaesthetic intoxication

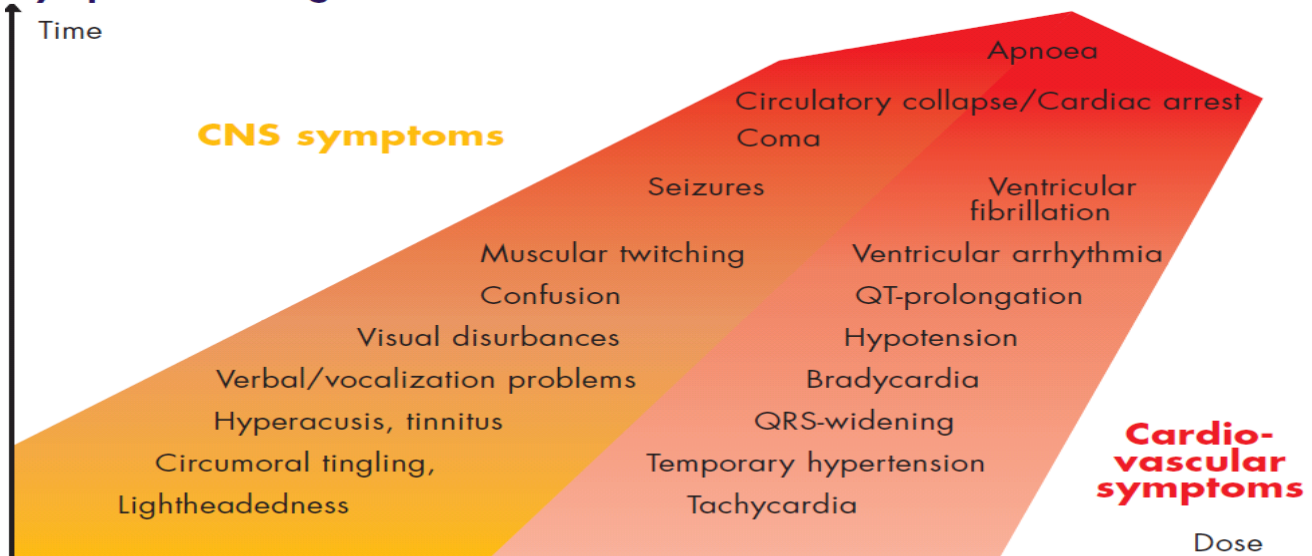

A relative small dose of local anaesthetic, if accidentally injected intravascularly, may lead directly to seizures with both respiratory and cardiovascular problems, depending on drug and patient conditions.

Suggested Reading

1. Campagna JA, Miller KW, Forman SA. Mechanisms of actions of inhaled anesthetics. *N Engl J Med* 2003;348:2110-2124.
2. Eger EI. Uptake and distribution. In: Miller RD, ed. *Anesthesia*, 6th ed. New York: Churchill Livingstone, 2005;131-153.
3. Kennedy, SK. Pharmacology of intravenous anesthetic agents. In: Longnecker DE,
4. *Clinical Anesthesia Procedures of the Massachusetts General Hospital*, 7th Edition
5. Copyright 2007©¹ Lippincott Williams & Wilkins

Chapter 9 Monitoring in anaesthesia

An important source of anaesthetic-related morbidity and mortality remains human error. All anaesthetists have tales of drug administration errors and ‘near-misses’; those anaesthetists who claim never to have problems are either doing insufficient work or are economical with the truth. A critical incident register is recommended in every anaesthetic department. A critical incident is an untoward event, which, if left uncorrected, would have led to anaesthetic-related mortality or morbidity. It includes many events ranging from disconnection of the breathing circuit to unrecognised oesophageal intubation and severe bronchospasm.

It is hoped that better monitoring will reduce the incidence of these complications.

There must be appropriate monitoring wherever anaesthesia is conducted, whether it is in the anaesthetic room, the operating theatre, the psychiatric department, the x-ray department, or in dental surgeries.

Indeed, anaesthetising ‘away from home’ outside the operating theatres demands particular care and appropriate monitoring *must be present*.

Monitoring facilities have improved greatly in recent years but still fall short of two essential requirements:

- the ability to monitor cerebral oxygenation;
- the ability to monitor routinely the depth of anaesthesia (many false dawns).

Full monitoring has three requirements as shown in Box 10.1.

Box Anaesthesia monitoring requirements

- Presence of anaesthetist
- Checking and monitoring anaesthetic equipment
- Patient monitoring
 - clinical
 - technical

Anaesthetist

The anaesthetist *must* be present throughout the whole surgical procedure and be readily available to recovery room staff until the patient leaves the theatre complex. *This responsibility is solely the anaesthetist's*, and is applicable in general and regional anaesthesia, and also in some sedation techniques where the anaesthetist is involved.

An adequate record must be made of the whole anaesthetic process, from the induction to full recovery of the patient. Errors can occur for a variety of reasons ranging from inexperience and lack of training to tiredness, boredom, and inattention. Vigilance in an anaesthetist is a function of self-motivation.

The novice anaesthetist should acquire rigorous monitoring habits. Tracheal intubation must be confirmed *every* time and the equipment, the anaesthetic machine and circuitry checked as a routine. Postoperative visits to assess a patient's progress are salutary and give an opportunity to improve aspects of care such as postoperative analgesia, nausea and vomiting.

Checking and monitoring equipment

Checking and monitoring the function of anaesthetic equipment has already been discussed in preceding chapters.

The means of maintaining airway control, intravenous fluids and infusion devices must be understood, the anaesthetic machine, circuits and ventilators must be checked. Two key features must be emphasised – the oxygen supply and the breathing systems.

Oxygen supply

The gas supply to the oxygen flowmeter must contain a low pressure warning device and have an audible alarm.

If hypoxic mixtures can be delivered (most old machines), then a device which monitors continuously the concentration of oxygen delivered to the patient must be fitted and have an audible alarm.

Breathing system

If faults exist in the circuit, these are best detected by monitoring the expired volume, the end-tidal carbon dioxide concentration and by measuring the airway pressure (high-pressure alarm). Clinical observation of the reservoir bag may reveal leaks, disconnections and overdistension from high pressure. During mechanical ventilation measurement of the airway pressure, the

How to survive in anaesthesia

expired volume, and carbon dioxide concentration are mandatory (see Chapter 9).

The alarm limits for equipment should be reset for each case and alarms should be turned ON (not turned off because the limits are being exceeded for a particular patient, but are not causing concern).

Patient monitoring

Clinical

The continuous observation of the patient's colour, chest movement and pattern of respiration, absence or presence of sweating and lacrimation, reactions of the pupil, use of a stethoscope, and palpation of a peripheral pulse provide essential basic monitoring of the patient. Much useful information can be obtained by simple observation, palpation and auscultation – arts that are rapidly disappearing from anaesthesia.

Technical

The circulation and ventilation need continuous monitoring in all forms of anaesthesia. If muscle relaxants are used, a peripheral nerve stimulator should be used. The devices used routinely are shown in Box .

Box Patient monitoring devices

- Cardiovascular
 - heart rate
 - electrocardiogram
 - noninvasive arterial pressure
 - oximeter
- Respiratory
 - respiratory rate
 - end-tidal carbon dioxide concentration
 - inspired oxygen
- Muscle relaxation
 - peripheral nerve stimulator

In specialised surgery, facilities for further monitoring are required (Box).

The *electrocardiogram* needs special emphasis because it is important to remember that electrical activity can exist even though there is no adequate cardiac output. Its value lies principally in monitoring changes in heart rate and in the diagnosis of arrhythmias.

Box Specialised patient monitoring devices

- Invasive arterial pressure
- Central venous pressure
- Pulmonary artery pressure
- Concentration of volatile anaesthetic agent
- Urine output
- Temperature measurement
- Measurement of blood loss
- Biochemical analysis: pH, arterial gas analysis, electrolytes
- Haematological analysis: haemoglobin, coagulation studies

Oximetry depends upon the differing absorption of light at different wavelengths by the various states of haemoglobin. Oxyhaemoglobin and reduced haemoglobin differ at both the red and infrared portions of the spectrum. The absorption is the same at 805 nm, the isobestic point. A pulse oximeter has two light sources on one side of the probe and a photodiode which generates a voltage when light falls upon it. The two emitting light sources are at 660 nm red (visible), and at 800 nm infrared (not visible).

The tissues absorb light but enough is transmitted to reach the photodiode. The arrival of the arteriolar pulsation with oxygenated blood alters the amount of red and infrared light transmitted through to the finger. This change is calculated by a microprocessor and the amount of oxygenated blood in the tissue deduced. The size and the shape of the arteriolar pulsation is shown as a plethysmographic trace.

The sigmoid shape of the oxygen dissociation curve means that saturations of above 90% show adequate tissue oxygenation.

Oximetry is unreliable in the following instances:

- excessive movement
- venous congestion
- excessive illumination
- nail polish/false nails
- intravenous drugs: methylene blue, indocyanine green
- carbon monoxide poisoning

A low oxygen saturation ($\text{SpO}_2 < 90\%$) demands an immediate response. Oxygenation of the tissues depends on the inspired oxygen concentration, lung function, haemoglobin concentration and cardiac output. The main causes of a low-oxygen saturation are shown in Box 10.4. If necessary, deliver

How to survive in anaesthesia

100% oxygen to the lungs while determining the cause of the hypoxaemia and starting appropriate treatment.

Box Causes of low oxygen saturation

- Oxygen supply
 - oxygen flow turned on?
 - machine delivering oxygen? (oxygen analyser)
 - vaporiser fault?
- Oxygen delivery to patient
 - circuit assembled correctly?
 - airway patent NO OBSTRUCTION?
 - tracheal tube sited correctly?
 - DISCONNECTION?
- Lung function
 - normal airway pressure?
 - tracheal tube in right main bronchus?
 - bronchospasm?
 - pulmonary oedema, pneumothorax?
- Haemoglobin
 - unrecognised haemorrhage?
 - hypovolaemia?
- Heart
 - adequate blood pressure?
 - arrhythmias?
- Tissues
 - septicaemia?

The most common cause of a low-oxygen saturation is an obstructed airway and this should be excluded before other diagnoses are considered.

Capnography is used to measure carbon dioxide. This utilises the principle of infrared absorption. When infrared light falls on a molecule, it enhances the molecule's vibrational energy and the infrared light is absorbed by the molecule. The amount of infrared light absorbed at a specific wavelength is proportional to the amount of carbon dioxide present in the gas mixture.

In the presence of a stable cardiac output, arterial carbon dioxide tension is related inversely to alveolar ventilation.

$$P_a\text{CO}_2 \propto 1/V_A$$

Common causes of high and low $P_a\text{CO}_2$ are shown in Box

Monitoring in anaesthesia

Box Common causes of high and low P aCO₂

- Low
 - hyperventilation
 - low cardiac output: embolism (gas or blood)
- High
 - hypoventilation
 - rebreathing carbon dioxide: circuit failures
 - hypermetabolic states: malignant hyperthermia

Full monitoring equipment should be available in the recovery room, as well as in theatre. It must also be available for the transportation and transfer of patients.

Conclusion

The most important monitor during any anaesthetic procedure is the presence of a trained, vigilant anaesthetist. **Under no circumstances must you ever leave the theatre while a patient is under your care.**

Careful, repetitive clinical observation of the patient is the next essential procedure, followed by the appropriate use of monitors to assess the respiratory and cardiovascular system.

These principles apply to all surgical procedures. There are 'small operations' but there is no such thing as a 'small anaesthetic'.

Chapter 10 Haemorrhage and blood transfusion

Estimation of blood loss

Surgeons cause blood loss and it is in their nature always to underestimate that loss. As an anaesthetist you must try to assess accurately the amount of blood shed and replace it with an appropriate intravenous solution. There are four main ways of estimating blood loss (Box).

Box Blood loss estimation

- Clinical observation
- Weighing of swabs
- Volume of suction
- Dilution techniques

During surgery it is a useful exercise to try to guess how much blood has been lost before checking with the estimate derived from weighing the swabs and measuring the volume of suction. With practice, your guess will become reasonably accurate for a known surgeon. However, this method should not be relied on and can be hopelessly inaccurate when you start working with a new surgical team.

Apart from surgical spillage, it is important to remember that, in trauma, patients will have occult loss in limb and pelvic fractures, and in chest or abdominal injuries.

Swab weighing relies on the principle that 1 ml of blood weighs approximately 1 g. A 3 × 4 inch swab weighs 20 g when dry and about 35 g when saturated. This 15 g difference represents about 15 ml of blood. An 18 × 18 inch swab contains about 150 ml of blood when saturated. Three of these large swabs full of blood contain about 450 ml, which is equivalent to one unit of whole blood.

How to survive in anaesthesia

The volume of fluid in the suction apparatus may contain surgical 'washing fluid' as well as blood. This overestimate is a useful precaution as the amount of blood on the surgical drapes, down the surgeons and on the floor cannot be measured. In major surgery it can easily be equivalent to 1–2 units of blood.

Dilution techniques are rarely used in clinical practice but rely on the measurement of the concentration of haemoglobin in the suction fluid to calculate the blood loss.

Patients should be transfused according to cardiovascular variables rather than relying on the estimates of blood loss. The heart rate, arterial pressure and central venous pressure are obvious guides and the measurement of the haematocrit or haemoglobin may be useful. A haemoglobin concentration of 10 g/dl, or a haematocrit of 30%, is often considered the lower limit of adequate oxygen delivery, even when the circulating blood volume and cardiac output are maintained. Although this limit is arbitrary, we have found it a useful practical guide and will transfuse red cells unless there are obvious contraindications. Lower values of 25% haematocrit or 8 g/dl haemoglobin concentration have been proposed, but there is then little physiological reserve if further rapid blood loss occurs.

Blood and blood products

Storage

Blood after donation is immediately cooled to 4–6°C. These temperature limits must be rigidly observed to preserve the red cells and minimise the multiplication of chance bacterial contaminants. Blood from the refrigerator should be used within 30 minutes.

A unit (500 ml) of blood is collected into a bag that contains 70 ml of citrate, phosphate, and dextrose (CPD) solution. The plasma is commonly centrifuged off for other use. The red cells are then suspended in a saline, adenine, glucose and mannitol (SAG-M) solution. The purpose of the storage additives is shown in Box .

Box Additives used in red cell storage

- Citrate: chelates calcium
- Phosphate: maintains ATP, reduces haemolysis and increases red cell survival
- Saline: decreases viscosity of red cell concentrates
- Adenine: maintains ATP, improves red cell mobility
- Glucose: energy for red cells, decreases hydrolysis of ATP
- Mannitol: reduces haemolysis

Haemorrhage and blood transfusion

Whole blood is devoid of functioning platelets after 2–3 days of storage and the clotting factors V and VIII are reduced to 10% of normal within 24 hours. Although adequate amounts of the coagulation factors I, II, VII, IX, X, XI, XII are present in whole blood, red cell concentrates contain virtually no coagulation factors.

Potassium concentrations rise progressively in stored blood and can reach up to 30 mmol/l after 3 weeks. Following transfusion, viable red cells re-establish their ionic pumping mechanism and intracellular uptake of potassium occurs rapidly. Blood ≥ 3 weeks old is acidic with pH values down to 6.6 and this results mainly from the lactic acid generated by red cell metabolism.

Preparations

There are about twenty different types of blood and blood products available for adult and paediatric use. The main ones used by anaesthetists are shown in Table .

Table Blood products in common use

Blood/blood product	Volume (ml) per unit	Storage temperature (°C)	Shelf life
Whole blood	500	4–6	35 days
Red cell concentrates	300	4–6	35 days
Fresh frozen plasma	150	–30	1 year
Platelet concentrates	50	22	5 days
Cryoprecipitate	18	–30	1 year

Fresh frozen plasma (FFP) contains all the components of the coagulation, fibrinolytic, and complement systems. In addition, it also has proteins that maintain oncotic pressure, fats and carbohydrates.

Cryoprecipitate contains factor VIII and fibrinogen.

Complications of blood transfusion

Complications of blood transfusion include those listed in Box 12.3.

Physical

Circulatory overload should be avoided by the judicious transfusion of blood according to the measured cardiovascular variables such as arterial pressure, central venous pressure, and heart rate. Air embolism can occur from errors in blood administration, particularly when the bags are pressurised. Microaggregates are platelet and white cell debris that are removed by the use of

How to survive in anaesthesia

Box Blood transfusion complications

- Physical
 - circulatory overload
 - embolism (air, microaggregates)
 - hypothermia
- Immunological
 - pyrogenic
 - type I hypersensitivity
 - graft versus host reactions
- Biochemical
 - acid base disturbances
 - hyperkalaemia
 - citrate toxicity
 - impaired oxygen release
- Infective
- Haemolytic transfusion reactions
- Disseminated intravascular coagulation

20–40 μm blood filters. These filters are either screen or depth in nature. Reduced transfusion of microaggregates may result in a decreased incidence of nonhaemolytic, febrile reactions, and less pulmonary injury and histamine release. Depth filters cause impaction and absorption of microaggregates and screen filters operate by direct interception of the microemboli. Blood filters cause increased resistance to blood flow, haemolysis, complement activation, and can deplete the blood of any remaining viable platelets. We do not believe that their value has been proven and never use them.

Anaesthetised patients have impaired temperature regulation and the rapid transfusion of cold blood exacerbates the hypothermia. The value of warming blood during transfusion has been demonstrated repeatedly and should be undertaken on every occasion.

Immunological

Pyrogenic reactions can occur in the recipient to white cell antigens or the polysaccharide products of bacterial metabolism. Rarely, stored blood contains gram negative bacteria. Plasma proteins are responsible for any anaphylactic or allergic reactions that happen. These reactions are rare, and range from severe hypotension to mild rashes. ‘Graft versus host’ reactions are caused by blood containing HLA-incompatible, immunocompetent lymphocytes being given to patients with immunosuppression. Pyrexia may

Haemorrhage and blood transfusion

develop and the disease can be fatal without suitable transfusion precautions. The use of leucocyte-depleted, red cell concentrates is expected to decrease the incidence of immunological complications.

It has been suggested, but is unproven, that patients with malignancy requiring transfusion have a greater risk of a recurrence.

Biochemical

The rapid infusion of large volumes of stored blood may result in acidosis in the recipient. This is particularly likely to occur if the liver is unable to metabolise the lactate and citrate because of inadequate hepatic perfusion, hypothermia and even hepatic disease. A persistent acidosis decreases myocardial function. A temporary improvement in cardiac output often follows the use of intravenous calcium chloride in these circumstances, although there is no obvious relationship to plasma ionised calcium values. The restoration of normal liver function usually corrects the problem.

Depletion of 2,3-diphosphoglycerate (DPG) in the red cells shifts the oxygen dissociation curve to the left and oxygen is released less easily from transfused blood. Modern additives have improved the concentration of 2,3-DPG for up to 14 days, and 25% of cells are back to normal function in 3 hours and 50% in 24 hours.

Infective

All blood products except albumin and gamma globulin can transmit infectious diseases. Hepatitis B, C, syphilis and HIV are screened for, but cytomegalovirus, malaria, Epstein-Barr virus, and parvovirus infection can be transmitted following transfusion.

Haemolytic transfusion reactions

Haemolytic and pyrogenic reactions are usually due to *errors* in the clerical administration of blood. However, blood group and rhesus incompatibility can also result in severe haemolytic reactions. Blood should be checked by two people against the patient's identity band. The recipient's name, hospital number, blood group and blood expiry date must be checked and signed for. In practice, during emergency work, it is often not possible for two people to check the blood and it is then *imperative that you slowly and deliberately check each unit*. Sometimes you have the opportunity to check all the blood before inducing anaesthesia.

Disseminated intravascular coagulation (DIC)

DIC is widespread activation of the coagulation and fibrinolytic systems, which results in clotting throughout the whole vasculature. It has many

How to survive in anaesthesia

possible causes, but can occur in 30% of cases of massive transfusion. It presents primarily as a haemorrhagic disorder caused by loss of platelets and soluble clotting factors (especially fibrinogen).

Massive blood transfusion

Various definitions exist for this term. It is normally defined in one of three ways:

- acute administration of more than 1.5 times the estimated blood volume
- the replacement of the patient's total blood volume by stored bank blood in less than 24 hours
- the acute administration of more than 10% of the blood volume in less than 10 minutes

Formulae for estimating the blood volume are shown in Box 12.4.

Box Blood volume formulae

- Neonate – 90 ml/kg
- Infants 2 years of age – 80 ml/kg
- Adult male – 70 ml/kg
- Adult female – 60 ml/kg

It is recommended that, after a six-unit transfusion, a set of basic screening tests is undertaken to exclude DIC. These are:

- haemoglobin and platelet count
- prothrombin time (PT) and activated partial thromboplastin time (APTT)
- plasma fibrinogen concentration
- fibrin degradation products
- pH from arterial blood gas analysis

The diagnosis of DIC is made by noting the trend:

- increase: APTT, PT, fibrin degradation products
- decrease: platelet count, fibrinogen concentration.

The correction of these abnormalities is made after haematological consultation.

The abnormalities in PT and APTT are normally corrected by the administration of FFP (4 units). A low platelet count should be restored to above $100 \times 10^9/l$ by the administration of 6–8 units of platelets. Low fibrinogen levels are treated with cryoprecipitate aiming for a level of less than 1 g/l (normal 2–4.5 g/l). If the patient has an arterial pH less than 7.2 and is continuing to bleed, the administration of 50 mmol bicarbonate (50 ml

Haemorrhage and blood transfusion

of 8.4% solution) should be considered. Recombinant activated factor VIIa can also be administered, if bleeding continues in spite of the use of FFP, platelets and cryoprecipitate.

Conclusion

Surgery results in blood loss. You must know how to estimate this loss, understand the blood products available and be able to use cardiovascular and haematological monitoring to transfuse them appropriately.

Think of blood as another potent drug that you will give frequently. It must be checked carefully before use, it can be life-saving, but also has unwanted side effects.

The greatest disaster is to give the wrong blood to the patient. It is imperative that the blood is checked against the patient's identity band; **never** check the blood bags solely with the transfusion form.

Chapter 11 **Common intraoperative problems**

Problems occurring during anaesthesia and surgery must be considered in an appropriate way. For example, the onset of an arrhythmia during surgery may have an anaesthetic cause, or result from surgical stimulation.

A disturbance of cardiac rhythm is not necessarily indicative of myocardial disease. If the arrhythmia is accompanied by sweating and hypertension it probably results from excessive sympathoadrenal activity.

You must learn to consider the causation of intraoperative problems in the following order:

- anaesthetic
- surgical
- medical

In particular, we recommend that the following safety check is undertaken whenever an unexpected problem arises.

- Is the anaesthetic machine working correctly?
- Are the gas flows correct?
- Is the circuit assembled correctly and working?
- Is the airway patent?

This fundamental principle of an anaesthetic cause, before a surgical cause, before a medical cause, cannot be overemphasised. The simple mechanistic approach that a bradycardia needs intravenous atropine will be fatal if the slow heart rate is a response to hypoxaemia following a disconnection within the circuit. Identifying the site of the disconnection and oxygenating the patient is the obvious priority. Common causes of intraoperative problems are shown in Box .

Some problems remain after anaesthetic and surgical causes have been eliminated and need specific treatment.

How to survive in anaesthesia

Box Common causes of intraoperative problems

- Anaesthesia
 - exclude HYPOXIA
 - exclude HYPERCAPNIA
 - response to laryngoscopy and intubation?
 - correct rotameter settings?
 - correct use of volatile agents?
 - pain?
 - awareness?
 - drugs correct? interactions?
 - adequate monitoring?
 - malignant hyperthermia?
- Surgery
 - reflex responses – eye, dental surgery, vagal stimulation?
 - retractors correctly sited?
 - haemorrhage – occult?
- Medical
 - specific diseases – cardiac?
 - undiagnosed disease – phaeochromocytoma?
 - electrolyte imbalance?
 - acid base balance?

Arrhythmias

Arrhythmias often occur in healthy patients undergoing anaesthesia. It is often difficult to interpret the ECG trace with only 6–7 beats observed on the screen. Atrial and ventricular ectopic beats are usually easily identified, but changes in P waves and ST segment changes may be hard to discern until extreme. Many modern monitors perform ST segment analysis routinely.

Treatment

If any anaesthetic or surgical cause for the arrhythmia is eliminated and the rhythm disturbance remains then five courses of action should be considered:

- 1 observation + no treatment
- 2 physical intervention
- 3 drug treatment
- 4 cardioversion
- 5 pacing

Common intraoperative problems

Careful observation with no immediate treatment is commonly undertaken in patients with occasional atrial and ventricular ectopic beats who are cardiovascularly stable (normal blood pressure and no evidence of cardiac failure). Physical interventions, other than the removal of retractors that may compress the heart, consist of stopping the surgery when a vagal response, such as a severe bradycardia or even a brief asystolic episode, occurs. Arrhythmias are often transient but they can age the novice anaesthetist who will, briefly, wish for a career in dermatology! Carotid sinus massage and gentle pressure on the eye are ineffective treatments for supraventricular tachycardias found under anaesthesia. Careful preoperative assessment should identify those patients who may need pacing and it is very unusual to need intraoperative pacing (complete heart block or symptomatic heart block). The drug treatments of life-threatening arrhythmias that we have found useful are summarised in Box . It is difficult to distinguish narrow and broad complex tachycardias during anaesthesia. A 12 lead electrocardiograph is needed and this is often impractical during surgery.

Box Drug treatment of life-threatening arrhythmias

- Sinus bradycardia
 - atropine 0.3 mg increments or glycopyrrolate 0.2 mg bolus
- Narrow complex tachycardias
 - adenosine 6 mg rapid bolus followed by second dose of 12 mg within one minute, if necessary
 - if hypotensive, signs of failure and heart rate of more than 200, give amiodarone 300 mg slowly and consider electrical cardioversion
- Broad complex tachycardias (pulse present)
 - amiodarone 150 mg over 10 minutes
 - or
 - lignocaine 50 mg over 5 minutes (repeated \times 3)
- Sudden onset atrial fibrillation
 - amiodarone 300 mg slowly

Synchronised DC cardioversion must be considered for the tachyarrhythmias listed in Box 17.2, if there are signs of heart failure, blood pressure less than 90 mm Hg, and a sustained heart rate of more than 150/minute.

Hypotension

Intraoperative hypotension is common and usually results from an inadequate blood volume following haemorrhage. The major causes are either a decreased

How to survive in anaesthesia

venous return or a direct depression of the myocardium due to mechanical causes, myocardial disease or anaesthetic drugs (Box).

Box Major causes of intraoperative hypotension

- Decreased venous return:
 - *haemorrhage*
 - vena caval compression – obstetrics, prone position
 - drugs, infection
 - anaesthesia without surgery
 - anaphylaxis
 - sepsis
 - epidural analgesia
- Myocardial depression:
 - mechanical
 - intermittent positive pressure ventilation
 - equipment and circuit malfunction
 - pneumothorax
 - cardiac tamponade
 - pulmonary embolus
 - cardiac disease
 - drugs

Treatment

Treatment is dependent on correct identification of the cause.

Rapid intravenous infusion of colloid fluid or blood may be required, together with measurement of the central venous pressure. The use of inotropic drugs should only be considered when you are sure that there is an adequate circulating blood volume. Epinephrine (adrenaline) is not an appropriate treatment for the hypotension of haemorrhage. Ensure that the hypotension is not a measurement error. Also check that there is not an excessive concentration of volatile agent.

Hypertension

Hypertension can occur from many causes and these are listed in Box.

Treatment is based on finding the cause of hypertension. Lack of analgesia or anaesthesia are the commonest causes. Ensure that the measurement is correct before starting treatment.

Common intraoperative problems

Box Causes of intraoperative hypertension

- Sympathetic stimulation
 - Hypoxia, hypercarbia
 - Inadequate level of anaesthesia awareness
 - pain
 - raised intracranial pressure
- Iatrogenic
 - incorrect drug administration
- Rare causes
 - malignant hyperthermia
 - phaeochromocytoma

Laryngospasm

Reflex closure of the glottis from spasm of the vocal cords is due usually to laryngeal stimulation. Common causes include insertion of a Guedel airway or laryngoscope, the presence of a tracheal tube and secretions in the airway. It can also arise as a response to surgical stimulation in a lightly anaesthetised patient. Thus, it occurs not only on induction of anaesthesia but also intraoperatively, and occasionally postoperatively.

The airway obstruction can lead to hypoxia and, in severe cases, pulmonary oedema can result.

Treatment

The management of laryngospasm depends on its severity, as shown in Box .

Box Management of laryngospasm

- 1** Identify stimulus and remove, if possible.
- 2** Give 100% O₂ and get help.
- 3** Ensure patent airway.
- 4** Tighten expiratory valve to apply a positive airway pressure to 'break' the spasm and increase O₂ intake with each breath. (BE CAREFUL.)
- 5** If unable to ventilate, give suxamethonium, endotracheal intubation, and deepen anaesthesia. Ensure intubation and ventilation is feasible.

There is a belief that a patient with severe laryngospasm and cyanosis will gasp a breath just before hypoxaemia is fatal. Do not try to verify this tenet – if in doubt paralyse and ventilate the patient.

How to survive in anaesthesia

Wheeze

Wheeziness during anaesthesia may be caused by many factors other than bronchospasm (Box 17.6). These causes must be eliminated before treatment for bronchospasm is started.

Box Differential diagnoses of wheeze

- Oesophageal intubation
- Tracheal tube in right main bronchus
- Kinked tracheal tube
- Tracheal tube cuff herniation over end of tube
- Secretions in tracheal tube
- Secretions in trachea/lungs
- Gastric acid aspiration
- Pneumothorax
- Pulmonary oedema
- Bronchospasm

Complications associated with intubation often cause wheeze and it is essential to check the position and patency of the endotracheal tube first.

Treatment

Treatment of intraoperative bronchospasm is as follows:

- 1 Consider changing volatile agent to halothane (bronchodilator).
- 2 Give salbutamol 250 µg slowly intravenously.
- 3 Give aminophylline 250–500 mg (4–8 mg/kg) intravenously over 10–15 min.
- 4 Give epinephrine 0.5–1.0 ml 1:10,000 increments intravenously.
- 5 Give hydrocortisone 100 mg intravenously.

Aspiration

Several factors make patients more prone to vomiting and aspiration of gastric contents in anaesthesia. These include trauma, a full stomach, opiates, raised gastric pressure (bowel obstruction, pregnancy) and diabetes. Aspiration may be particulate or liquid and concealed or obvious. Use of an appropriate anaesthetic technique (i.e. rapid sequence induction) safeguards patients most at risk.

Common intraoperative problems

Patients with wheeze must be suspected of having aspirated and a post-operative chest x-ray may reveal a right lobe infiltrative pattern. Aspiration usually occurs into the right lung.

Treatment is aimed at securing the airway, aspirating the trachea and ensuring oxygenation. If severe surgery should be abandoned. Saline lavage of the trachea and bronchi may be useful (under supervision) and antibiotics are given. The patient must be monitored closely postoperatively.

Conclusion

Many problems occur during the induction and maintenance of anaesthesia, and recovery of a patient. Whatever the problem, a cause must be sought in the following sequence: anaesthetic–surgical–medical. Only when the first two have been eliminated should specific medical therapy be started.

Chapter 12 Postoperative problems

Intraoperative problems described in the previous chapter (arrhythmias, hypotension, laryngospasm and wheeze) may continue, or even start, in the postoperative period. Investigation of the cause and subsequent management of these problems is identical, regardless of the time of onset.

Airway obstruction

Obstruction of the airway is a common occurrence after anaesthesia. It must be rapidly diagnosed (Box), the cause sought (Box), and appropriate treatment started.

Box Signs of airway obstruction

- 'See-saw' respiration pattern
- Suprasternal and intercostal recession
- Tachypnoea
- Cyanosis
- Tachycardia
- Arrhythmias
- Hypertension
- Anxiety and distress
- Sweating
- Stridor

During emergence from anaesthesia patients may have incomplete mouth, pharyngeal, and laryngeal control, causing airway obstruction. Hypoxaemia will result if the airway is not maintained. Patients are turned routinely into the lateral or 'recovery position' to help prevent this problem. The patient is usually placed in the left lateral position as reintubation is easier because laryngoscopes are designed to be inserted into the right side of the mouth.

Box Common causes of postoperative airway obstruction

- Anaesthesia
 - unconsciousness with obstruction by tongue
 - laryngeal oedema
 - laryngeal spasm
- Surgery
 - vocal cord paralysis (thyroid surgery)
 - neck haematoma
 - preoperative neck and face inflammation (infection)

If there is a possibility that aspiration may have occurred with the patient in the supine position, then they should be placed in the right lateral position to prevent contamination of the left lung.

Patients who are at risk of aspiration should be extubated when the airway reflexes are intact. Although this is less pleasant for the patient, it is much safer.

The treatment of airway obstruction is to identify the cause, and clear the airway, often with suction, to ensure patency. Extension of the neck, jaw thrust, and insertion of an oropharyngeal airway are often required. Laryngeal oedema is treated by intravenous dexamethasone 8 mg. Oxygenation of the patient is the priority and, if you are in doubt, reintubation must be undertaken. Many problems in anaesthesia are caused by inadequate attention to the airway. Remember, a patent airway is a happy airway.

Failure to breathe

Failure to breathe adequately at the end of anaesthesia has many causes, both common (Box) and unusual (Box).

Differentiation between central and peripheral causes of failure to breathe can only be made by using a nerve stimulator. A peripheral nerve, such as the ulnar nerve at the wrist, is stimulated. Ensure that the nerve stimulator is working correctly; if necessary, try it on yourself first.

Adequate return of neuromuscular function is assessed by observing a 'train of four' stimulation. Four twitches should be seen and the ratio of twitch 4 : twitch 1 response must exceed 70%. This is not easy to decide and we recommend that they should appear about equal. This ensures safety. A sustained tetanic response following high frequency stimulation also indicates adequate neuromuscular function (Box).

How to survive in anaesthesia

Box Common causes of failure to breathe

- Central nervous system
 - depression from drugs:
 - opiates
 - inhalational agents
 - decreased respiratory drive:
 - hypocapnia
 - Peripheral
 - failure of neuromuscular transmission:
 - inadequate reversal of competitive relaxants
 - overdose of competitive relaxants
 - cholinesterase deficiency

Box Unusual causes of failure to breathe postoperatively

- Hypothermia
- Drug interactions:
 - aminoglycosides and competitive relaxants
 - ecothiopate and suxamethonium
- Central nervous system damage
- Electrolyte disorders:
 - hypokalaemia
- Undiagnosed skeletal muscle disorders:
 - myasthenia gravis
- Extensive spinal anaesthetic in combination with general anaesthesia

Box Signs of adequate neuromuscular function

- Evoked responses:
 - train of four ratio >70%
 - sustained tetanic response to high frequency stimulation
 - return of single twitch to control height
- Clinical responses:
 - lift head for 5 seconds
 - sustained hand grip
 - open eyes widely
 - sustained tongue protrusion
 - effective cough
 - adequate tidal volume
 - vital capacity 15–20 ml/kg

Postoperative problems

If a nerve stimulator is not available, there are clinical tests that can be made to indicate the return of normal neuromuscular activity. If inadequate neuromuscular function is found, the lungs must be ventilated and the use of neuromuscular blocking drugs reviewed.

Prolonged apnoea after suxamethonium occurs when the patient has an abnormal genetic variant of the plasma enzyme, cholinesterase. The patient and members of the family should be investigated at a later date and susceptible individuals asked to carry warning cards.

Only when you are certain that neuromuscular transmission is normal should a central cause for failure to breathe be considered. Again the lungs must be ventilated, a normal end-tidal CO₂ concentration obtained and possible causes assessed (see Box 18.3).

An overdose of opioid is a common reason for failure to breathe. This can be treated with low doses of intravenous naloxone 40 µg, but this potent antagonist is short-acting and the return of adequate respiration is usually accompanied by a complete lack of analgesia! This is an unsatisfactory mess and it is better to ventilate the lungs until the central depressant effects of the drugs have worn off, or consider intravenous doxapram.

Nausea and vomiting

Nausea and vomiting are particularly unpleasant complications of anaesthesia and surgery. The avoidance of these problems is more important to some patients than the provision of adequate analgesia. There are many factors associated with the occurrence of nausea and vomiting (Box 18.6). This long list indicates that often there is no single, identifiable cause, although opioids are frequently at fault.

Because patients find nausea and vomiting distressing, it should be prevented if possible. The medical consequences of vomiting include the possibility of acid aspiration, electrolyte imbalance and dehydration, inability to take oral drugs and disruption of the wound. A vomiting patient upsets other patients in the recovery area and surgical ward.

Most anaesthetists prescribe antiemetics, but the consensus is that they should not be given prophylactically unless patients are deemed high risk. Drugs used include cyclizine, prochlorperazine, droperidol, metoclopramide and ondansetron. The newer agents seem little better than traditional drugs.

Delayed awakening

Failure to recover full consciousness after surgery is always worrying for the anaesthetist. A systematic review of the patient is necessary (Box).

How to survive in anaesthesia

Box Factors associated with postoperative vomiting

- Patient predisposition
 - age, sex, menstrual cycle, obesity
 - history of postoperative vomiting
 - history of motion sickness
 - anxiety, pain
 - recent food intake, prolonged fasting
- Surgical factors
 - type of surgery
 - emergency surgery
- Anaesthetic factors
 - inhalational agents
 - intravenous induction agents
 - opiates
 - duration of anaesthesia
 - distension of gut
 - oropharyngeal stimulation
 - experience of anaesthetist
- Postoperative factors
 - pain
 - hypotension
 - hypoxaemia
 - movement of patient
 - first intake of fluids/food
 - early mobilisation

The most common causes are drug related, but you must also remember the possibility of a low temperature, low blood glucose, low plasma sodium and low circulating thyroid hormones.

Shivering

Shivering is common during recovery from anaesthesia, but is not obviously related to a low core temperature in the patient. It is more frequent in young men who have received volatile agents and its incidence is decreased by the use of opiates during anaesthesia. The main deleterious effect of shivering is an increase in O_2 consumption. This is of little consequence in young, fit patients, but it should be treated promptly in the elderly who often have impaired cardiac and respiratory function.

Box Causes of delayed recovery

- Hypoxaemia
- Hypercapnia
- Residual anaesthesia
- Drugs, especially opiates
- Emergence delirium from ketamine, scopolamine, atropine
- Neurological causes
- Surgery: neurosurgery, vascular surgery
- Metabolic causes:
 - hypoglycaemia
 - hyponatraemia
- Medical causes: hypothyroidism
- Sepsis
- Hypothermia

Pethidine 25 mg intravenously is effective in stopping shivering; other opioids can also be used. Low doses of intravenous doxapram are an alternative to opiates if there is a risk of respiratory depression. The simple application of heat to the 'blush area' (the face and upper chest) stops shivering. This indicates the importance of skin temperature in stimulating shivering, as the effect on body temperature is negligible.

Temperature disturbances

A decrease in body temperature is an inevitable accompaniment of anaesthesia. Indeed, it has been noted that the most effective means of cooling a person is to give an anaesthetic. Hypothermia (defined as a core temperature more than 35°C) can occur after major surgery and the predisposing factors are shown in Box 18.8.

Complications of postoperative hypothermia may include shivering (see above), impaired drug metabolism and enhanced platelet aggregation. There are several methods available for preventing loss of body heat during surgery (Box), and a combination of treatments is necessary. For example, the theatre temperature must be maintained at 24°C, the inspired gases humidified, the intravenous fluids warmed and the skin surface warmed.

Hyperthermia after anaesthesia is uncommon (Box 18.10). In the list below infection is the most common cause, and the potentially lethal complication of malignant hyperthermia should be diagnosed only after arterial gas analysis and determination of circulating potassium values (see Chapter 14).

How to survive in anaesthesia

Box Factors predisposing to postoperative hypothermia

- Ambient theatre temperature
- Age, young and elderly
- Surgery
 - duration
 - size of incision
 - insulation
- Concomitant disease
- Intravenous fluid administration
- Drug therapy such as vasodilators

Box Prevention of body heat loss

- Ambient theatre temperature
- Airway humidification
- Warm skin surface
 - passive insulation
 - active warming
 - water blanket
 - radiant heater
 - forced air warmer
- Warm intravenous fluids
- Oesophageal warming

Box Causes of hyperthermia

- Infection
- Environmental
- Mismatched transfusion
- Drugs
 - interactions
 - atropine overdose
- Metabolic
 - malignant hyperthermia
 - phaeochromocytoma
 - hyperthyroidism

Cyanosis

Cyanosis is a serious sequelae of anaesthesia and, whenever it occurs, must be investigated promptly.

- 1 Check oxygen delivery from anaesthetic machine and circuit.
- 2 Check airway. Is endotracheal tube correctly positioned and patent?
- 3 Having excluded these causes, consider:
 - fault in chest (is ventilation easy?):
 - bronchospasm
 - pulmonary oedema
 - pneumothorax
 - pulmonary effusion/haemothorax.
 - fault in circulation:
 - decreased venous return
 - cardiac failure
 - embolism
 - drug reaction.
- 4 Rare causes include:
 - methaemoglobinaemia
 - malignant hyperthermia.

Problems of the airway are the most common causes of cyanosis and you must be *certain* that the airway is patent and the patient is breathing O₂ before considering other causes.

Conclusion

Postoperative problems often reflect errors of judgement made during surgery. Get it right intraoperatively and your patients will have fewer difficulties postoperatively. Nursing staff in the recovery area and surgical wards rapidly assess your anaesthetic skills by the smoothness of recovery of your patients.

Chapter 13 Principles of emergency anaesthesia

In elective surgery the correct diagnosis has been made (usually), any medical disorders have been identified and treated, and an appropriate period of starvation has been determined. During emergency work, however, one or more of these conditions are often not met. In addition, there are further problems such as:

- dehydration
- electrolyte abnormalities
- haemorrhage
- pain

The components of general anaesthesia are the same, whether it is conducted for elective surgery or emergency surgery (Box).

Box Components of general anaesthesia

- Preoperative assessment
- Premedication
- Induction
- Maintenance
- Reversal
- Postoperative care

The key to success in emergency anaesthesia is a thorough preoperative assessment. It should be undertaken as described in Chapter . Particular attention must be given to investigate medical problems, the occurrence of hypovolaemia and an evaluation of the airway. On the basis of the preoperative clinical assessment, together with the results of *relevant* investigations, a decision for an appropriate time to operate can be reached.

There are very few patients with a potentially life-threatening clinical state that they need immediate surgery, i.e. a true 'emergency' (Box). A vast majority of patients greatly benefit from the correction of

How to survive in anaesthesia

hypovolaemia and electrolyte abnormalities, stabilisation of medical problems, such as diabetes and cardiac arrhythmias, and waiting for the stomach to empty.

If necessary, preoperative optimisation should be undertaken in ITU. Surgeons are not known for their patience and often view any delay in operating as time wasted. *When to operate* is the most important decision that has to be made in emergency work. Fortunately, for the patient, and for you, increasingly this decision is made by senior staff. In the early stages of your anaesthetic career you should observe closely the evidence used to reach such decision.

Although it is usually assumed that emergency anaesthesia means general anaesthesia, other methods can sometimes be employed (Box 22.2).

Box Classification of anaesthetic techniques

- General anaesthesia
 - intubation of unprotected airway
 - spontaneous respiration or controlled ventilation
 - use of muscle relaxants
- Regional anaesthesia
- Combination of general and regional anaesthesia
- Sedation
 - intravenous
 - inhalational
- Combination of sedation and regional anaesthesia

There is increasing use of regional anaesthesia, but hypovolaemia must be corrected preoperatively. Sedation should not be confused with general anaesthesia. The sedated patient can talk to the anaesthetist at all times. If not, then airway control may be lost with the risk of aspiration of gastric contents.

Full stomach

Patients for elective surgery are usually starved for 4–6 hours to ensure an empty stomach, but can receive clear fluids for up to 2 hours before induction of anaesthesia. Nevertheless, every few years we have the unpleasant experience of dealing with elective patients who vomit undigested food at least 12 hours after the meal in the absence of any intestinal abnormalities. In emergency surgery it is usual to starve the patient for at least 4–6 hours. However, this rule is unreliable and all emergency patients should be treated as having a full stomach and so at risk of vomiting, regurgitation and aspiration.

Principles of emergency anaesthesia

Vomiting occurs at the induction of, and emergence from, anaesthesia. If gastric acid enters the lungs a pneumonitis results, which can be fatal. Aspiration can also occur following passive regurgitation of gastric contents up the oesophagus. This regurgitation is often described as 'silent' to distinguish it from active vomiting. Regurgitation is particularly likely at induction of anaesthesia when several drugs used (atropine, thiopentone, suxamethonium) decrease the pressure in the lower oesophageal sphincter.

In emergency anaesthesia there is always a risk of aspiration, regardless of the period of starvation. Therefore, the trachea must be intubated as rapidly as possible after induction of anaesthesia. The methods available are shown in Box. If preoperative assessment of the airway indicates no problems then endotracheal intubation is performed under general anaesthesia. However, *if a difficult airway is predicted then senior help must be called*.

Box Methods of facilitating tracheal intubation

- Patient awake
 - topical anaesthesia
- Patient anaesthetised
 - use of muscle relaxants
 - suxamethonium
 - competitive relaxants
 - inhalational techniques

There are some basic requirements for endotracheal intubation in emergency surgery.

- Skilled assistance must be present
- The trolley must tip
- The suction apparatus must work correctly and be left on
- A range of sizes of endotracheal tubes must be available
- Spare laryngoscopes must be available
- Ancillary intubation aids, gum elastic bougie and stillettes must be available

A plan of management of the patient who may have a full stomach and is at risk of aspiration is shown in Box.

Neither physical nor pharmacological methods should be relied on to empty the stomach completely. In some specialties such as obstetrics, an H_2 receptor blocking drug, ranitidine, is given routinely to decrease gastric acid secretion

How to survive in anaesthesia

Box Management of endotracheal intubation when risk of aspiration

- Empty stomach
 - from above by nasogastric tube
 - from below by drugs, for example, metoclopramide
- Neutralise remaining stomach contents
 - antacids
 - use of H₂ blocking drugs to prevent further acid secretion
- Stop central nervous system induced vomiting
 - avoid opiates
 - use of phenothiazines
- CORRECT ANAESTHETIC TECHNIQUE
 - ‘rapid sequence induction’
 - preoxygenation, cricoid pressure, intubation

and 30 ml sodium citrate used orally 15 minutes before induction of anaesthesia to increase the pH of the gastric contents. Opiates delay gastric emptying and increase the likelihood of vomiting.

The only reliable way to prevent regurgitation is to use the correct anaesthetic technique. This is now called a rapid sequence induction, which sounds better than the old term – crash induction. It has three essential components: preoxygenation, cricoid pressure, intubation.

Preoxygenation

Before induction the patient must breathe 100% oxygen for at least 3 minutes from a suitable breathing circuit. There should be no leaks and the flow rate of oxygen in the circuit should be high to prevent rebreathing. Air contains oxygen, nitrogen and minimal carbon dioxide. When the patient is breathing oxygen only, the lungs denitrogenate rapidly and after 3 minutes contain only oxygen and carbon dioxide. There is now a greater reservoir of oxygen in the lungs to utilise before hypoxia occurs.

Anaesthesia is then induced and cricoid pressure applied.

Cricoid pressure

The cricoid cartilage is identified on the patient before anaesthesia is induced and the patient warned that they might feel pressure on the neck as they go to sleep. The skilled assistant presses down on the cricoid cartilage as anaesthesia is induced and *this pressure is applied continuously until the anaesthetist tells the assistant to stop* (Fig. 22.1).

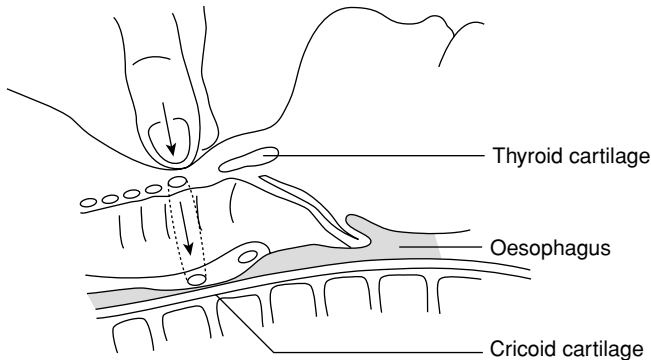

Figure 22.1 Application of cricoid pressure.

The object of pressure on the cricoid cartilage is to compress the oesophagus between the cricoid cartilage and vertebral column. This prevents any material that has been regurgitated from the stomach into the oesophagus from passing into the pharynx.

Cricoid pressure is usually undertaken by firm, but gentle, pressure on the cartilage by the thumb and forefinger of the assistant. It is similar to the pressure exerted that causes mild pain when the thumb and forefinger are pressed onto the bridge of the nose. The cricoid cartilage is used because it is easily identifiable, forms a complete tracheal ring, and the trachea is not distorted when it is compressed.

The patient has now received preoxygenation, an induction agent, and cricoid pressure. A neuromuscular blocking drug is given to facilitate intubation of the trachea.

Intubation

The neuromuscular blocking drug must act rapidly and have a short duration of action. The lungs are not ventilated during a rapid sequence induction; this will prevent accidental inflation of the stomach, which will further predispose the patient to regurgitation and vomiting. Gases can be forced into the oesophagus and stomach during manual ventilation of the lungs despite the application of cricoid pressure.

A drug with a rapid onset of action permits quick endotracheal intubation. An agent with a short duration of action is valuable because in cases of failed intubation spontaneous respiration will return promptly. This allows other options to be considered .

How to survive in anaesthesia

Suxamethonium has many side effects (Box) but remains the best drug available.

Major side effects of suxamethonium

- Muscle aches
- Bradycardia
- Raised intracranial pressure
- Raised intraocular pressure
- Raised intragastric pressure
- Allergic reactions
- Hyperkalaemia in burns, paraplegia, some myopathies
- Prolonged action in pseudocholinesterase deficiency
- Malignant hyperthermia

Only when the trachea is intubated, the cuff inflated and the correct position of the tube is confirmed, the cricoid pressure is released.

The anaesthetic is maintained, usually with a volatile agent, nitrous oxide, oxygen, competitive relaxant and suitable analgesia. The reversal of the relaxant at the end of the procedure is undertaken with the anticholinesterase, neostigmine. Atropine or glycopyrrolate is given concomitantly to stop bradycardia occurring from the neostigmine.

Rapid sequence induction has the major disadvantage of potential haemodynamic instability, as hypertension and tachycardia often occur following laryngoscopy and intubation. This is often more severe than in elective surgery when opiates are often given at induction of anaesthesia.

Other indications for rapid sequence induction

Every anaesthetic, not just emergency work, should be considered from the point of view of unexpected vomiting or regurgitation. Some cases are at high risk and rapid sequence induction should be considered carefully as an option in this group (Box 22.6).

Pulmonary aspiration

Pulmonary aspiration may be obvious. The presence of lager and curry in the pharynx when the blade of the laryngoscope is inserted is a depressing sight. It may also be silent, presenting as a postoperative pulmonary complication.

Principles of emergency anaesthesia

Box High risk factors for regurgitation

- Oesophageal disease
 - pouch
 - stricture
- Gastro-oesophageal sphincter abnormalities
 - hiatus hernia
 - obesity
 - drugs
- Gastric emptying delay
 - trauma
 - pyloric stenosis
 - gastric malignancy
 - opiates
 - patient predisposition, anxiety
 - pregnancy
 - recent food intake
- Abnormal bowel peristalsis
 - peritonitis
 - ileus – metabolic or drugs
 - bowel obstruction

The signs of pulmonary aspiration are shown in Box

Box Signs of pulmonary aspiration

- None
- Oxygen desaturation
- Coughing
- Tachypnoea
- Unexplained tachycardia
- Wheeze
- Hypotension
- Pneumonitis
- Postoperative pulmonary disease

Treatment requires the advice of a senior anaesthetist. The airway must be suctioned and *oxygenation of the patient remains the priority*. Bronchoscopy may be required to remove particulate matter. If the patient is not paralysed

How to survive in anaesthesia

then, surgery permitting, he or she should be allowed to wake up. If paralysed, intubation and ventilation must occur and oxygenation maintained.

Bronchospasm may be treated with aminophylline. Further treatment may include antibiotics, other bronchodilators and steroids. Aggressive early management is required.

Conclusion

Anaesthesia for emergency surgery needs careful preoperative assessment and adequate resuscitation must be undertaken before surgery.

Impatient surgeons must be restrained. A rapid sequence induction of anaesthesia must follow the order of preoxygenation, cricoid pressure and intubation to prevent aspiration of gastric contents.

Chapter 14 Regional anaesthesia

Local anaesthetic agents are used to provide intraoperative analgesia, either as the sole anaesthetic technique or in combination with sedation or general anaesthesia. You should learn the principles of regional anaesthesia at an early stage of your training.

The drugs in common use are lignocaine, bupivacaine and prilocaine, their characteristics are shown in Table 23.1. The choice of drug depends on the speed of onset and duration of action required. Epinephrine (adrenaline) prolongs the latter.

Table Characteristics of local anaesthetic drugs

Agent	Duration (h)	Maximum dose	
		Plain (mg/kg)	With epinephrine (mg/kg)
Lignocaine	1–3	3	7
Bupivacaine	1–4	2	2
Prilocaine	1–3	4	8

Local anaesthetic drugs have serious side effects if given in excess, or inadvertently released into the circulation. Toxicity is manifested in a variety of ways ranging from mild excitation to serious neurological and fatal cardiac sequelae (Box 23.1).

Epinephrine is sometimes added to the local anaesthetic to prolong its action, and to decrease the vascularity of an operative field (for example, in thyroid surgery). It must not be used near terminal arterioles or arteries, as an adequate collateral arterial supply is not available to perfuse distal tissues, and ischaemia will occur. The recommendations for the safe use of epinephrine are listed in Box 23.2.

How to survive in anaesthesia

Box Symptoms and signs of local anaesthetic toxicity

- Anxiety
- Restlessness
- Nausea
- Tinnitus
- Circumoral tingling
- Tremor
- Tachypnoea
- Clonic convulsions
- Arrhythmias
 - ventricular fibrillation
 - asystole

Box Recommendations for the safe use of epinephrine in local anaesthetic solutions

- No hypoxia
- No hypercapnia
- Caution with arrhythmogenic volatile agents, for example, halothane
- Concentration of $\leq 1:200,000$
- Dose < 20 ml of 1:200,000 in 10 minutes
- Total dose < 30 ml/hour

Occasionally, the anaesthetist is responsible for supervising the preparation of a 1:200,000 epinephrine solution. The commonly available dilutions of epinephrine are 1:10,000 and 1 in 1000. Therefore, either:

1 ml of 1:10,000 epinephrine diluted to a total volume of
20 ml = 1:200,000 solution

or

0.1 ml of 1:1000 epinephrine diluted to a total volume of
20 ml = 1:200,000 solution.

The former is more accurate, as measuring 0.1 ml exactly is not easy. A similar calculation to that described in Chapter 11, shows that 1 ml of 1:200,000 epinephrine solution contains 5 μ g epinephrine.

Before undertaking regional anaesthesia, the criteria outlined in Box 23.3 must be considered and satisfied.

Sterility of the anaesthetist does not refer to their reproductive capacity, but means wearing a gown, mask, hat and gloves.

Box Requirements before starting regional anaesthesia

- Informed consent
- Vascular access
- Resuscitation drugs and equipment
- Sterility of anaesthetist
- Sterility of operative site
- No contraindications to procedure
- Correct dosage of local anaesthetic drug

Epidural anaesthesia

The epidural space runs from the base of the skull to the bottom of the sacrum at the sacrococcygeal membrane. The spinal cord, cerebrospinal fluid and meninges are enclosed within it (Fig. 23.1).

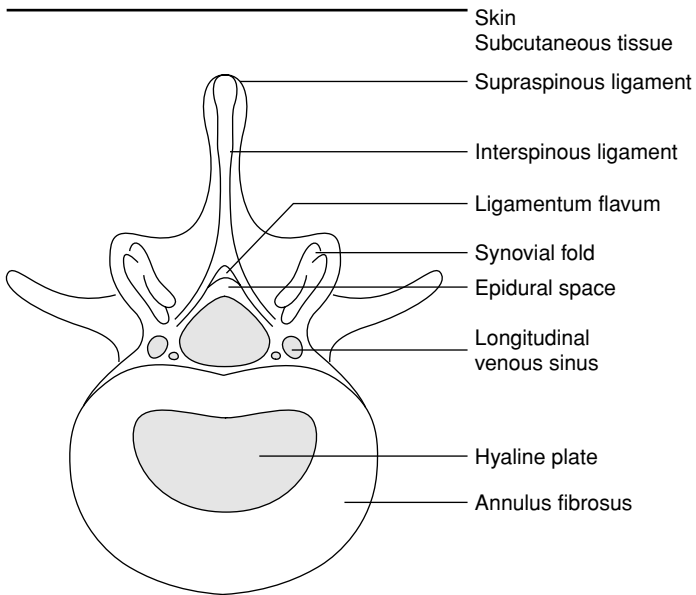

Figure Anatomy of the epidural space.

The spinal cord becomes the cauda equina at the level of L2 in an adult and the cerebrospinal fluid stops at the level of S2. The epidural space is

How to survive in anaesthesia

3–6 mm wide and is defined posteriorly by the ligamentum flavum, the anterior surfaces of the vertebral laminae, and the articular processes. Anteriorly it is related to the posterior longitudinal ligament and laterally is bounded by the intervertebral foraminae and the pedicles.

The contents of the epidural space are:

- nerve roots
- venous plexus
- fat
- lymphatics

The veins contain no valves and communicate directly with the intracranial, thoracic and abdominal venous systems.

Contraindications to epidural anaesthesia are shown in Box 23.4. Abnormal clotting may result in haemorrhage in a confined space if an epidural vein is punctured during the insertion of an epidural cannula. An epidural haematoma then causes spinal cord compression. Local skin infection may introduce bacteria into the spinal meninges with the risk of an abscess or meningitis. Similarly in septicaemia, if a vein is punctured then the small haematoma is a good culture medium for bacteria.

Box Absolute and relative contraindications to epidural anaesthesia

- Absolute
 - patient refusal
 - abnormal clotting
 - infection – local on back, septicaemia
 - allergy to local anaesthetic drug
- Relative
 - raised intracranial pressure
 - hypovolaemia
 - chronic spinal disorders
 - central nervous system disease
 - drugs – aspirin, other NSAIDs, low-dose heparin

Although the evidence that spinal disorders are exacerbated by the insertion of an epidural catheter is poor, patients are often quick to blame the anaesthetic procedure. The same principle applies to patients with neurological problems such as multiple sclerosis. The evidence that drugs that mildly affect clotting or platelet function (for example, non-steroidal anti-inflammatory drugs) cause abnormal bleeding in the epidural space and increase the risk of an epidural haematoma is minimal.

The equipment used for the insertion of an epidural catheter is shown in Fig. .

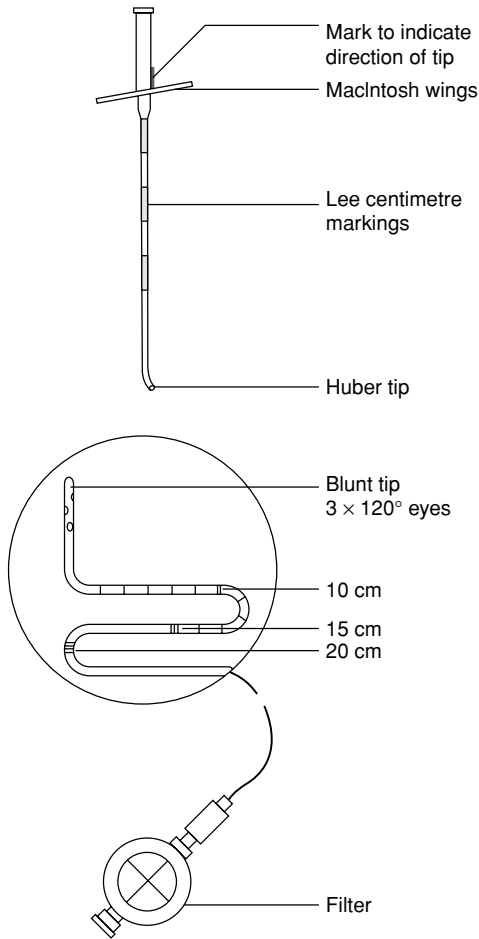

Figure Tuohy needle, epidural catheter and filter.

The Tuohy needle is either 16 or 18 gauge. It is 10 cm long: 8 cm of needle and 2 cm of hub. It is marked in centimetres and has a curved ‘Huber’ tip. The epidural catheter has three holes at 120° alignment with the holes 2 cm from the end of the catheter. The catheter is marked in centimetre gradations up to 20 cm. The filter has a 0.2 μm mesh that stops the injection of particulate matter, such as glass, and bacteria into the epidural space.

How to survive in anaesthesia

The correct technique of insertion of an epidural catheter must be learnt under careful supervision. The conditions listed in Box 23.2 must be met. An intravenous infusion of either crystalloid or colloid is set up to give a 'fluid load' of about 500 ml before the local anaesthetic is injected. This is undertaken to decrease the likelihood of hypotension with the onset of the epidural block. Atropine and a vasopressor should always be drawn up before starting the block.

The procedure can be done in either the lateral or sitting position and ideally the spine should be flexed. A slow, controlled advance of the Tuohy needle is essential, using a syringe and a loss of resistance technique. The needle passes through skin, subcutaneous tissue, supraspinous ligament, interspinous ligament, ligamentum flavum, and finally enters the epidural space. The ligaments resist the injection of air or saline, but when the needle enters the epidural space the resistance is lost.

The choice is between using air or saline to identify the epidural space. The *advantages of air* are that:

- any fluid in the needle or catheter must be cerebrospinal fluid
- there is less equipment on the tray
- it is cheaper

The *disadvantages of air* are that:

- injection of large volumes may result in patchy blockade
- there is a theoretical risk of air embolus

The *advantages of saline* are that:

- it is a more reliable method of identifying the epidural space
- the catheter passes more easily into epidural space

The *disadvantages of saline* are that:

- fluid in the needle or catheter, may be saline or cerebrospinal fluid; the latter is warmer and contains glucose but rapid clinical decisions are difficult
- there is additional fluid on the tray with increased risk of error

We recommend you become thoroughly familiar with either air or saline before trying the alternative method. There is no 'correct' method; one author uses air and the other uses saline.

The epidural space is usually found at a distance of about 4–6 cm from the skin. Place the catheter rostrally and, using the centimetre markings on the needle and catheter, insert 3 cm of catheter into the epidural space.

The filter and catheter, once correctly positioned and fixed, must be aspirated to ensure that no blood or cerebrospinal fluid can be withdrawn.

Regional anaesthesia

The local anaesthetic drug is given in small, incremental doses to reduce the risk of complications.

The complications of epidural blockade, assuming no technical difficulties in the location of the space and the siting of the catheter, are shown in Boxes

Box Major complications of epidural analgesia

- Severe hypotension
- Accidental intravenous injection
- Dural puncture
 - massive spinal anaesthetic
 - headache

Box Other complications of epidural analgesia

- Leg weakness
- Shivering
- Atonic bladder
- Contraction of the small bowel
- Backache
- Isolated, reversible nerve damage from catheter/needle trauma
- Epidural haematoma
- Epidural abscess
- Meningitis

Hypotension results from a decreased venous return to the heart as a consequence of vasodilation induced by the sympathetic blockade. The 'fluid load' helps to prevent hypotension, but a vasoconstrictor, such as ephedrine in 3–6 mg intravenous increments, is often given to restore normal arterial pressure.

The risks of the intravenous injection of local anaesthetic are minimised by aspiration of the cannula and by giving small incremental doses. If blood is aspirated, usually the cannula is removed and the epidural resited in a different space. Occasionally, the cannula can be withdrawn from the epidural vein and no blood aspirated. Then the epidural catheter must be flushed with saline to ensure the cannula is not in a vein before further use.

Accidental, dural puncture occurs when the needle or cannula is inserted into the cerebrospinal fluid. If this is not recognised and a full epidural

How to survive in anaesthesia

dose of local anaesthetic is injected into the wrong place, a massive spinal anaesthetic will result with apnoea, severe hypotension, and total paralysis. The lungs have to be ventilated and the circulation supported during this period. For this reason, an epidural 'test dose' of 2–3 ml of local anaesthetic is given by many anaesthetists before the full dose is injected (for example, 2% lignocaine). In the epidural space this dose of local anaesthetic has little effect, but in the cerebrospinal fluid an extensive block occurs rapidly. After 10 minutes the epidural dose of local anaesthetic is given if no adverse effects are noted.

A severe postural headache following dural puncture is managed by resting the patient in a flat position, simple analgesics, adequate hydration, caffeine and, if necessary, a 'blood patch'. The dural puncture can be sealed by placing 20 ml of the patient's blood into the epidural space under aseptic conditions. The resulting clot will rapidly stop the leak and is effective in virtually all patients. Two anaesthetists are required for this manoeuvre.

Opiates can also be given in the epidural space to prolong the effects of local anaesthetics and to provide postoperative analgesia. They have different complications (Box 23.7) of which respiratory depression is the most serious. Regular monitoring of respiratory function is essential (see Chapter 28).

Box Complications of epidural opiates

- Delayed respiratory depression
- Drowsiness
- Itchiness
- Nausea and vomiting
- Urinary retention

Spinal anaesthesia

This is the deliberate injection of local anaesthetic into the cerebrospinal fluid (CSF) by means of a lumbar puncture. It is normally given as a single injection, but can be used in conjunction with epidural anaesthesia (combined spinal-epidural anaesthesia) for longer procedures.

The incidence of headache following dural puncture is dependent on the size and type of spinal needle. Not surprisingly, the smaller the diameter of the needle, the lower the incidence of headache (remember 27 gauge is *smaller* than 25 gauge).

Pencil-tip, spinal needles, such as Whiteacre and Sprotte, split, rather than cut, the dura and also reduce the risk of headache.

Local anaesthetic solutions for spinal anaesthesia are isobaric or hyperbaric with respect to the CSF. Isobaric solutions are claimed to have a more predictable spread in the CSF, independent of the position of the patient. Hyperbaric solutions are produced by the addition of glucose and their spread is partially influenced by gravity. Many factors determine the distribution of local anaesthetic solutions in the CSF; this makes prediction of the level of blockade difficult (Box 23.8).

Box Factors influencing distribution of local anaesthetic solutions in CSF

- Local anaesthetic drug
- Baricity
- Dose of drug
- Volume of drug
- Turbulence of cerebrospinal fluid
- Increased abdominal pressure
- Spinal curvatures
- Position of patient
- Use of vasoconstrictors
- Speed of injection

The complications of spinal anaesthesia are the same as for epidural anaesthesia. Neuronal blockade is more rapid in onset so that the side effects, such as hypotension, occur promptly. In spinal anaesthesia the duration of the block is variable but is usually shorter than that of epidural analgesia.

Caudal anaesthesia

The caudal space is a continuation of the epidural space in the sacral region. The signet-shaped, sacral hiatus is formed by the failure of fusion of the laminae of the fifth sacral vertebra. The hiatus is bounded laterally by the sacral cornua and is covered by the posterior sacrococcygeal ligament, subcutaneous tissue and skin. The epidural space is located by passing a needle through the sacral hiatus. The caudal canal contains veins, fat and the sacral nerves. The cerebrospinal fluid finishes at the level of S2.

Caudal anaesthesia is used for operations in areas supplied by the sacral nerves, such as anal surgery and circumcision. The precautions are the same as those described for epidural analgesia. The needle must be aspirated after insertion to exclude blood and cerebrospinal fluid. The complications are the same as for epidural anaesthesia, although motor blockade can be a major problem in the early postoperative period if the patient wants to walk.

How to survive in anaesthesia

Hypotension is uncommon, as the neuronal blockade usually does not spread rostrally to reach the sympathetic chain.

The extent of a block can be measured by the absence of pain or temperature sensation at a dermatomal level (Table 23.2). The former is tested with a sharp needle and the latter with an ethyl chloride spray.

Table Dermatomal levels at various anatomical landmarks

Anatomical landmark	Dermatological levels
Nipples	T4
Xiphisternum	T6
Umbilicus	T10
Symphysis pubis	L1/T12

Intravenous regional analgesia

A limb can be anaesthetised by the administration of local anaesthetic intravenously distal to a tourniquet placed high on the limb. This technique is used on the arm only, because the leg needs toxic doses of local anaesthetics. It is used commonly for manipulation of fractures and brief operations on the hand. The precautions mentioned in Box must be adhered to.

An intravenous cannula is inserted into a vein on the dorsum of the hand. A single or double cuff is placed around the humerus. If a double cuff is used, the higher cuff is compressed first until the arm is anaesthetised, and then the lower cuff is inflated over the numb skin to make it more comfortable for the patient. The cuff is pressurised to 250–300 mmHg and about 40 ml 0.5% prilocaine without epinephrine (see Table) injected into the arm. The patient will often only tolerate the cuff for 45–60 min because of pain. The cuff must remain inflated for at least 20 minutes, otherwise systemic toxicity may occur from rapid uptake of the drug when the tourniquet is released.

The main problem with this block is the tourniquet. It must not deflate accidentally.

Conclusion

Regional anaesthesia is fun for the anaesthetist and provides excellent analgesia for the patient. The successful use of these techniques depends on learning good technical skills to match understanding of essential anatomy, physiology and pharmacology.

Start early in your career – make the epidural space a familiar territory.

Chapter 15 Management of the patient in the recovery area

At the end of surgery, the patient is transferred to the recovery area and is looked after by trained staff. The anaesthetist must explain what specific care is required in addition to the routine observations. The patient remains the responsibility of the anaesthetist during this time and an anaesthetist must be available immediately should any problems arise. If you have any doubts about leaving the patient in the care of the recovery staff, then you must remain with the patient. Your duty lies with the patient you have just anaesthetised – the remaining cases have to wait.

The equipment and monitoring facilities in the recovery room should be the same as in a fully equipped operating theatre.

The objectives of care in the recovery room are shown in Box 30.1.

Box Main objectives of care in the recovery area

- Assessment of conscious level
- Management of the airway
- Pain control
- Essential monitoring and observation
- Avoidance of nausea and vomiting
- Management of shivering
- Temperature control
- Care of intravenous infusion
- Observation of surgical wound drainage
- Observation of urine output
- Oxygen therapy

Most units have guidelines on routine monitoring in the recovery area and you must be familiar with them. One member of staff per patient is mandatory in the early postoperative period. Essential monitoring consists of careful, clinical observation, and regular measurement of heart rate, arterial pressure,

How to survive in anaesthesia

respiration and oxygen saturation. These measurements may be taken as frequently as every 5 minutes after major surgery, but at intervals of 15 minutes following routine, minor surgery. In most units 'routine postoperative care' means recording the vital signs every 15 minutes. It may be desirable to monitor the patient by means of invasive techniques, such as arterial and central venous cannulation, and suitable equipment should be available in the recovery area.

Oxygen therapy

Oxygen therapy is often given routinely in the postoperative period as hypoxaemia is an inevitable consequence of major surgery. The main causes of early postoperative hypoxaemia are shown in Box .

However, hypoxaemia can persist for several days.

Box Causes of early postoperative hypoxaemia

- Hypoventilation
 - airway obstruction
 - central respiratory depression
 - respiratory muscle weakness
- Ventilation/perfusion abnormalities
- Increased oxygen consumption
 - shivering
- Impaired response to hypoxaemia
- Decreased oxygen content
 - low cardiac output
 - low haemoglobin values

Diffusion hypoxia is a transient phenomenon that occurs at the end of anaesthesia when nitrous oxide is replaced by air. Nitrous oxide enters the alveoli from the blood very rapidly. Because nitrogen is much less soluble than nitrous oxide, expired volume exceeds inspired volume, and there is a dilutional effect on oxygen in the alveoli.

The main causes of early postoperative hypoxaemia are a degree of *airway obstruction*, central respiratory depression usually caused by opiates, and respiratory muscle weakness resulting from inadequate reversal of neuromuscular blocking drugs. Ventilation/perfusion abnormalities can arise after prolonged general anaesthesia and are exacerbated by factors such

Management of the patient in the recovery area

as obesity and pulmonary disease. Even very low concentrations of volatile anaesthetic agents impair the ventilatory response to hypoxaemia.

Oxygen is administered usually by a mask; either a fixed performance or variable performance device.

Fixed performance oxygen masks

These masks provide an accurate inspired oxygen concentration which is independent of the patient's ventilation because the flow rate of fresh gas delivered is higher than the patient's inspiratory flow rate. They work on the principle of high air flow oxygen enrichment (HAFOE). Air is entrained in oxygen by means of the Venturi principle to provide accurate concentrations of 24, 28, 35, 40, and 60% oxygen, depending on which mask is used. The flow rates of oxygen required for these concentrations are written on the side of each mask. Such masks, for example, the Ventimask, are expensive and are indicated when a precise concentration of oxygen needs to be given, such as in chronic obstructive lung disease. Following routine anaesthesia cheaper, variable performance masks are used.

Variable performance oxygen masks

Variable performance masks, such as the Hudson mask, depend on the patient's inspiratory flow rate, the oxygen flow rate, and the duration of the expiratory pause. Nasal cannulae function in a similar way. If a patient is breathing normally then an oxygen flow of 4 l/min will provide an inspired oxygen concentration of about 40%. If necessary, this can be checked with an oxygen analyser.

If an inspired oxygen concentration of more than 60% is required, it cannot usually be given by a disposable oxygen mask. An anaesthetic face mask is necessary.

Criteria for discharge from the recovery room are becoming common. The main points of anaesthetic relevance are shown in Box 30.3.

Box Typical criteria for discharge from recovery

- Patient awake and responds appropriately to commands
- Upper airway patent and reflexes present
- Respiration satisfactory
- Cardiovascular stability
- Pain control adequate, not vomiting

How to survive in anaesthesia

Conclusion

The care of the patient in the recovery room remains the responsibility of the anaesthetist, who must be available to deal with any complications that may arise. The anaesthetist is also responsible for the discharge of the patient from the recovery area to the ward and increasingly this is a formal, documented procedure.

Chapter 16 Anaesthesia for day case surgery

The assessment of day case patients is usually straightforward and is often delegated to senior nurses and new trainees. Surgeons frequently consider only the duration of surgery when deciding whether an operation can be undertaken on a day case basis. Their ability to ignore serious, chronic medical problems must never be underestimated. Most units have strict guidelines about the selection of patients for surgery as day cases. The most important considerations are the medical status of the patient, the potential surgical complications and the implications and side effects of anaesthesia. Typical selection guidelines are shown in Box

Box Selection guidelines for day case surgery

- Medical: ASA 1 and 2 only
 - age >2 years <80 years
 - obesity – BMI <30
- Surgical: operating time <45 min
 - minor and intermediate procedures
 - exclude procedures with significant postoperative pain
 - exclude procedures with significant risk of bleeding
 - exclude procedures with resultant significant disability
- Anaesthetic: no previous anaesthetic difficulties
- Social: must live within 10 miles/1 hour of hospital
 - must not go home by public transport
 - must have a responsible, fit escort
 - must be supervised by a responsible fit adult for 24 hours

In essence, the purpose of the guidelines is to ensure that relatively simple surgery with minimal complications is undertaken on healthy patients.

Day case units are often isolated from the rest of the hospital and may not be equipped and staffed to the same standards as the main theatre complex. Provisions must be available to admit the occasional day case patient who has

Anaesthesia for day case surgery

anaesthetic or surgical complications. After routine surgery the key decision is when to discharge the patient and suitability is often assessed by the criteria shown in Box 29.2.

Box Discharge criteria for day case surgery

- Stable vital signs for 1 hour after surgery
- No evidence of respiratory depression
- Orientated to person, place and time (or return to preoperative status)
- Ability to maintain oral fluids
- Ability to pass urine (particularly after regional anaesthesia)
- Able to dress (consistent with preoperative status)
- Able to walk (consistent with preoperative status)
- Minimal pain
- Minimal nausea and vomiting
- Minimal surgical bleeding
- Suitable escort present
- Written instructions for postoperative care

These criteria have been further developed in some units with the adoption of scoring systems to minimise subjective bias (Table).

Table Discharge scoring criteria

Check	Result	Points
Vital signs:	within 20% preoperative values	2
	within 20–40% preoperative values	1
	outside 40% preoperative values	0
Activity/mental status:	orientated $\times 3$ and steady gait	2
	orientated $\times 3$ or steady gait	1
	neither	0
Pain/nausea/vomiting:	minimal	2
	moderate, needed treatment	1
	severe, needs treatment	0
Surgical bleeding:	minimal	2
	moderate	1
	severe	0
Intake/output:	taken oral fluids and voided	2
	taken oral fluids or voided	1
	neither	0

Score ≥ 8 – fit for discharge

Score < 8 – unfit, medical assessment needed

Conclusion

Careful assessment of the patient presenting for day case surgery is essential to spot the medical problems missed by the surgeons. Adherence to the local selection guidelines should ensure a trouble-free anaesthetic, operation and recovery. However, do not expect all patients to obey instructions.

One author anaesthetised a local GP for a minor surgical procedure who discharged himself at noon to ride a motorcycle home for a light lunch before taking afternoon surgery!

Chapter 17 Postoperative analgesia

Pain is a subjective response to noxious stimuli and patients vary greatly in their need for analgesia after surgery. For example, the amount of morphine requested postoperatively varies tenfold after the same operation. Analgesic regimens must take into account this unpredictable response. Acute pain teams are a popular, recent development in anaesthetic practice and have drawn attention to past failings in the provision of adequate, postoperative analgesia.

The advantages claimed for good analgesia are shown in Box .

Box Claimed advantages of good postoperative analgesia

- Humanitarian reasons
- Psychological reasons
- Fewer respiratory complications
- Fewer adverse cardiovascular responses
- Fewer autonomic complications (sweating, vomiting)
- Earlier mobilisation
- Less deep vein thrombosis
- Earlier return to normal life style/work

The humanitarian and psychological advantages of good analgesia are obvious. Pain, especially after abdominal surgery, can lead to deterioration in respiratory function from a reduction in ventilatory capacity and an inability to cough. Pulmonary atelectasis and infection are more likely. Pain causes tachycardia and hypertension, and this may exacerbate any existing myocardial ischaemia. Sweating and vomiting may accompany pain and good analgesia makes early mobilisation and rehabilitation easier.

How to survive in anaesthesia

Influences on postoperative pain

Postoperative pain is affected by many factors including those listed in Box .

Box Factors influencing postoperative pain

- Age
- Sex
- Social class
- Anxiety
- Understanding of surgery
- Attitudes of staff
- Pain relief in other patients
- Type of surgery
- Type of anaesthesia

The elderly tolerate pain better than younger adults and women are more stoical than men. People in social classes III, IV and V tolerate pain better than those in social classes I and II. Patients with a high, preoperative neuroticism score experience more pain. A reduction in anxiety and education of the patient about the surgery have been shown to decrease postoperative pain.

The attitudes of staff and the adequacy of analgesia provided for other patients on the ward are also important. Staff who are reluctant, or have little time to provide good postoperative analgesia, adversely affect the patient's recovery. Fear of the side effects of drugs (for example, addiction to opiates) is a totally unacceptable reason for the nursing staff not providing as much analgesic as required.

Methods of postoperative analgesia

An approach to the postoperative analgesic requirements of the patient must be considered during the preoperative visit. A typical plan is shown in Box 31.3.

The importance of the preoperative visit and explanation to the patient of the procedures cannot be overemphasized. Consent for unusual routes of drug administration (for example, rectal in British patients) must be obtained. In some patients postoperative analgesia starts with premedication and the administration of opiates.

Box General plan of postoperative analgesia

- Preoperative assessment and discussion with patient
- Premedication
- Systemic drugs
 - nonsteroidal anti-inflammatory drugs
 - opiates
 - route
 - oral
 - intramuscular
 - intravenous
 - subcutaneous
 - rectal
 - mode of administration
 - patient-controlled or by medical staff
 - continuous versus intermittent methods
- Regional anaesthetic techniques
 - local anaesthetic agent
 - addition of opiate
 - route
 - epidural
 - spinal
 - caudal
 - specific nerve blocks
 - wound infiltration
 - mode of administration – single bolus at surgery/intermittent/infusion
- Miscellaneous techniques
 - steroids
 - Entonox
 - transcutaneous nerve stimulation
 - acupuncture
- Benefits versus side effects
- Follow-up

Systemic drugs

Nonsteroidal anti-inflammatory drugs (NSAIDs) such as aspirin, paracetamol, diclofenac and piroxicam can be given as oral analgesics. These agents are often mixed with codeine and dihydrocodeine, which are occasionally given by themselves. The choice of drugs depends on the personal preference of the anaesthetist. NSAIDs have important side effects (Box 31.4).

How to survive in anaesthesia

Box Main side effects of NSAIDs

- Gastric ulceration
- Decreased platelet aggregation
- Drug interactions (for example, diuretics and serum potassium)
- Hypersensitivity
- Renal impairment

Morphine is the 'gold standard' opiate drug and is widely used for post-operative analgesia. Pethidine is claimed to be less sedative and have relaxant properties on smooth muscle. We consider pethidine to be a potent emetic and weak analgesic and never use it. All opiates have side effects (Box 31.5).

Box Major side effects of systemic opiates

- Nausea and vomiting
- Sedation
- Dysphoria
- Euphoria
- Constipation
- Delayed stomach emptying
- Hallucinations

The traditional method of providing postoperative analgesia, by giving intramuscular morphine on request by the patient, has many drawbacks including intermittent analgesia and inadequate dosage. New advances in opiate administration have occurred recently.

Patient-controlled analgesia (PCA)

Syringe pumps have been devised so that the patients (not visitors, or members of staff) can administer their own analgesia intravenously. The pumps must be safe and programmed to provide sufficient analgesia after major surgery (Table 31.1). Once programmed they must be locked so that neither the syringe of opiate nor the controls are accessible. Patient-controlled analgesia does not mean patient-programmed analgesia. Careful explanation to the patient about PCA is essential for the success of the technique.

In theory, if patients become too drowsy they will not push the button and so will not receive excessive doses of opiate. Despite this, staff must monitor, at least hourly, the severity of the pain, the amount of analgesia used, the

Postoperative analgesia

Table Typical regimen for intravenous morphine PCA pump

Drug details	Regimen
Dose	50 mg in 50 ml sodium chloride
Concentration	1 mg/ml
Bolus dose	1 mg
Lock out time	5 minutes
Hourly dose limit	12 mg

degree of sedation, and the respiratory rate. If the respiratory rate is less than 10 breaths/min or the patient too drowsy, the infusion must be stopped. The opiate antagonist, naloxone, must be available and can be given in cases of severe respiratory depression, but it should be remembered that analgesia will also be reversed.

Subcutaneous infusions

Opiates can be administered subcutaneously by continuous infusion pumps that are altered by the staff, not the patient. Morphine is given at a concentration of 2.5 mg/ml (50 mg in 20 ml sodium chloride solution). For example, the infusion is given at a rate of 1.25–3.75 mg/h. Increments of 2.5 mg can be given for breakthrough pain. Monitoring must be undertaken as described above; overdose again causes severe drowsiness and respiratory depression.

Regional techniques

Local anaesthetic drugs can be administered either as a single bolus, intermittent injections, or a continuous infusion. They can be given into the subcutaneous tissue around a wound, into joints, the pleural cavity, and in the region of the spinal cord (epidural, spinal, caudal). Opiates are often given by the epidural route, either in combination with local anaesthetics, or individually, to provide analgesia. Local anaesthetics have toxic side effects and are discussed with the more common nerve blocks in Chapter 23. The balance of possible complications versus benefits must be considered.

Miscellaneous

Entonox (50% N₂O:50% O₂) is used to help alleviate the pain of short-lived procedures such as the removal of chest drains. Steroids can reduce swelling and consequently pain in dental procedures.

Transcutaneous nerve stimulators and acupuncture are used occasionally as adjuncts to other analgesic techniques.

How to survive in anaesthesia

Conclusion

Many techniques are currently available to provide pain relief after surgery. Side effects are inevitable and some of these, such as vomiting with opiates, can be distressing. It is essential that you see the effectiveness or otherwise of the chosen postoperative analgesic regimen and ask the patients for their opinions.

INTRAVENOUS ANESTHETICS

A. Benzodiazepines

Include midazolam, lorazepam, and diazepam. They are often used for sedation, amnesia, anxiolysis, or as adjuncts to general anesthesia. Midazolam is prepared in a water-soluble form at pH 3.5, while diazepam and lorazepam are dissolved in propylene glycol and polyethylene glycol, respectively.

1. Mode of action. Enhance inhibitory neurotransmission by increasing the affinity of GABA_A receptors for GABA.

2. Pharmacokinetics

- a. After IV administration, the onset of CNS effects occurs in 2 to 3 minutes for midazolam and diazepam (slightly longer for lorazepam). Effects are terminated by redistribution; therefore, durations of a single dose of diazepam and midazolam are similar. The effects of lorazepam are somewhat more prolonged.
- b. All three drugs are metabolized in the liver. Elimination half-lives for midazolam, lorazepam, and diazepam are approximately 2, 11, and 20 hours, respectively. The active metabolites of diazepam last longer than the parent drug and accumulate with repeated dosing. Hydroxymidazolam can accumulate and cause sedation in patients with renal failure.
- c. Diazepam clearance is reduced in the elderly, but this is less of a problem with midazolam and lorazepam.

3. Pharmacodynamics

a. CNS

1. Amnestic, anticonvulsant, anxiolytic, muscle-relaxant, and sedative-hypnotic effects in a dose-dependent manner. Amnesia may last for only 1 hour after a single premedicant dose of midazolam. Sedation may sometimes be prolonged.
2. Do not produce significant analgesia.
3. Dose-dependent reduction of CBF and CMRO₂.

b. Cardiovascular system

1. Mild systemic vasodilation and decrease in cardiac output. HR is usually unchanged.
2. Hemodynamic changes may be pronounced in hypovolemic or critically ill patients if rapidly administered in a large dose or with an opioid.

c. Respiratory system

1. Mild dose-dependent decreases in RR and TV.
2. Respiratory depression may be pronounced if administered with an opioid, in patients with pulmonary disease or in debilitated patients.

4. Dosage and administration.

Diazepam for premedication Oral 0.2-0.5 mg/kg

Midazolam for premedication IM 0.07-0.15 mg/kg

Lorazepam for premedication Oral 0.053 mg/kg

5. Adverse effects

- a. **Drug interactions.** Administration of a benzodiazepine to a patient receiving the anticonvulsant **valproate** may precipitate a psychotic episode.
 - b. **Pregnancy and labor**
 1. May be associated with a slightly increased risk of cleft lip and palate when administered during the first trimester.
 2. Cross the placenta and may lead to CNS depression in the neonate.
 - c. **Superficial thrombophlebitis and injection pain** may be produced by the vehicles in diazepam and lorazepam.
6. **Flumazenil** (imidazobenzodiazepine) is a competitive antagonist at the benzodiazepine binding site of GABA_A receptors in the CNS.
- a. Reversal of benzodiazepine-induced sedative effects occurs within 2 minutes; peak effects occur at approximately 10 minutes. Does not completely antagonize the respiratory depressant effects of benzodiazepines.
 - b. Half-life is shorter than the benzodiazepine agonists, so repeated administration may be necessary.
 - c. Metabolized to inactive metabolites in the liver.
 - d. **Dose.** 0.3 mg IV every 30 to 60 seconds (to a maximum dose of 5 mg).
 - e. **Contraindicated** in patients with tricyclic antidepressant overdose and in those receiving benzodiazepines for the control of seizures or elevated ICP. Use cautiously in patients who have had long-term treatment with benzodiazepines because acute withdrawal may be precipitated.

B. Barbiturates

Such as thiopental and methohexital rapidly produce unconsciousness (30 to 45 seconds) after IV administration, followed by rapid termination of effects due to redistribution. Barbiturate preparations for IV administration are highly alkaline (pH >10) and are usually prepared as dilute solutions (1.0% to 2.5%).

- 1. Mode of action.** barbiturates facilitate inhibitory neurotransmission by enhancing GABA_A receptor function. They also inhibit excitatory neurotransmission via glutamate and nicotinic acetylcholine receptors.

2. Pharmacokinetics

- a.** Hepatic metabolism. Methohexital has a much higher clearance than thiopental. Thiopental is metabolized to pentobarbital, an active metabolite with a longer half-life.
- b.** Multiple doses or prolonged infusions may produce prolonged sedation or unconsciousness due to the reduced rate of redistribution, the return of the drug to the central compartment, and slow hepatic metabolism.

3. Pharmacodynamics

a. CNS

- 1.** Dose-dependent CNS depression ranging from sedation to unconsciousness. Much higher doses are required to suppress responses to painful stimuli.
- 2.** Dose-dependent cerebral vasoconstriction and decrease in cerebral metabolic rate (CMRO₂) cause reductions in ICP and cerebral blood flow (CBF). Cerebral autoregulation remains unaffected.
- 3.** Dose-dependent depression of EEG activity. At high doses, thiopental will produce an isoelectric EEG. In contrast, methohexital can elicit seizure activity.

b. Cardiovascular system

- 1.** Cause venodilation and depress myocardial contractility, leading to dose-dependent decreases in BP and cardiac output, especially in patients who are preload dependent.
- 2.** Baroreceptor reflexes remain largely intact; therefore, HR may increase in response to hypotension.

c. Respiratory system

- 1.** Dose-dependent decreases in RR and TV. Ventilatory responses to hypoxia and hypercarbia are markedly depressed. Apnea may result for 30 to 90 seconds after an induction dose.

2. Laryngeal reflexes remain more intact compared with propofol; therefore, the incidence of cough and laryngospasm is higher.

4. Dosage and administration.

Thiopental for induction IV 3-6 mg/kg (2.5% concentration)

for sedation IV 0.5-1.5 mg/kg (2.5% concentration)

Methohexital for induction IV 1-2 mg/kg (1% concentration)

for sedation IV 0.2-0.4 mg/kg (1% concentration)

N.B. Reduce doses in hypovolemic, elderly, or hemodynamically compromised patients.

5. Adverse effects

- a. **Allergy.** True allergies are unusual. Thiopental occasionally causes anaphylactoid reactions (i.e., hives, flushing, and hypotension) due to histamine release.
- b. **Porphyria**
 1. **Absolutely contraindicated** in patients with acute intermittent porphyria, variegate porphyria, and hereditary coproporphyria.
 2. Barbiturates induce porphyrin synthetic enzymes such as δ -aminolevulinic acid synthetase; patients with porphyria may accumulate toxic heme precursors and suffer an acute attack.
- c. **Venous irritation and tissue damage**
 1. May cause pain at the site of administration due to venous irritation.
 2. Thiopental can cause severe pain and tissue necrosis if injected extravascularly or intra-arterially. If intra-arterial administration occurs, heparin, vasodilators, and regional sympathetic blockade may be helpful in treatment.
- d. **Myoclonus** and **hiccups** are often seen during induction with methohexital.

C. Propofol

(2, 6-diisopropylphenol) is used for the induction or maintenance of general anesthesia and for conscious sedation. It is prepared as a 1% isotonic oil-in-water emulsion, which contains egg lecithin, glycerol, and soybean oil. Bacterial growth is inhibited by ethylenediaminetetraacetic acid (EDTA), diethylenetriamine pentaacetic acid (DTPA), sulfite, or benzyl alcohol depending on the manufacturer.

1. **Mode of action.** Facilitates inhibitory neurotransmission by enhancing the function of γ -aminobutyric acid type A (GABA_A) receptors in the central nervous system (CNS). The modulation of glycine receptors, *N*-methyl-D-aspartate (NMDA) receptors, cannabinoid receptors, and voltage-gated ion channels may also contribute to propofol's actions.
2. **Pharmacokinetics**
Hepatic and extrahepatic metabolism to inactive metabolites which are renally excreted.
3. **Pharmacodynamics**
 - a. **CNS**
 1. Induction doses rapidly produce unconsciousness (30 to 45 seconds), followed by a rapid termination of effect due to redistribution. Emergence is rapid and often accompanied by mood elevation. Low doses produce sedation and amnesia.
 2. Weak analgesic effects at hypnotic concentrations.
 3. Decreases intracranial pressure (ICP) and also cerebral perfusion pressure (CPP) due to markedly decreased mean arterial pressure (MAP). Cerebral autoregulation as well as vasoconstriction in response to hyperventilation are unaffected.
 4. Propofol is an anticonvulsant and raises the seizure threshold more than that with methohexital.
 5. Dose-dependent suppression of electroencephalogram (EEG) activity. Higher doses cause burst suppression and isoelectric EEG.
 6. Postoperative nausea and vomiting (PONV) occurs less frequently after a propofol-based anesthetic compared with other techniques, and subhypnotic doses have antiemetic effects.
 - b. **Cardiovascular system**
 1. Dose-dependent decreases in preload, afterload, and contractility lead to decreases in blood pressure (BP) and cardiac output. Hypotension may be marked in hypovolemic, elderly, or hemodynamically compromised patients.
 2. Heart rate (HR) is minimally affected, and baroreceptor reflex is blunted.
 - c. **Respiratory system**
 1. Dose-dependent decreases in respiratory rate (RR) and tidal volume (TV).

2. Ventilatory responses to hypoxia and hypercarbia are diminished.

4. Dosage and administration.

Propofol for induction IV 1-2.5mg/kg

for sedation IV 25-100 μ /kg/min

- a. Titrate with reduced incremental doses in hypovolemic, elderly, or hemodynamically compromised patients or if administered with other anesthetics.
- b. Relatively larger induction and maintenance doses are required in infants and small children.
- c. Propofol emulsion supports bacterial growth despite the addition of antimicrobials; prepare drug under sterile conditions, label with date and time, and discard unused, opened propofol after **6 hours** to prevent inadvertent bacterial contamination.

5. Adverse effects

- e. **Venous irritation.** May cause pain during IV administration, which can be reduced by administration in a large vein or by adding lidocaine to the solution (e.g., 20 mg of lidocaine to 200 mg of propofol).
- f. **Lipid disorders.** Propofol is a lipid emulsion and should be used cautiously in patients with disorders of lipid metabolism (e.g., hyperlipidemia and pancreatitis).
- g. **Myoclonus** and **hiccups** can occur after induction doses, although less frequently than with methohexital or etomidate.
- h. **Propofol infusion syndrome** is a rare and often fatal disorder that occurs in critically ill patients (usually children) subjected to prolonged, high-dose propofol infusions. Typical features include rhabdomyolysis, metabolic acidosis, cardiac failure, and renal failure.

C. Etomidate

A sedative-hypnotic agent most commonly used for IV induction of general anesthesia. It is supplied in a solution containing 35% of propylene glycol.

- 1. **Mode of action.** Facilitates inhibitory neurotransmission by enhancing GABA_A receptor function.
- 2. **Pharmacokinetics**
 - a. After an induction dose, times to loss of consciousness and return of consciousness are similar to that for propofol. Effects of a single bolus dose are terminated by redistribution.
 - b. Very high clearance in the liver and by circulating esterases to inactive metabolites.
- 3. **Pharmacodynamics**

a. CNS

1. No analgesic properties.
2. Cerebral blood flow (CBF), cerebral metabolic rate, and intracranial pressure decrease while CPP is usually maintained. Cerebral vasoconstriction in response to hyperventilation is preserved.
3. Dose-dependent depression of EEG activity, with burst suppression at higher doses.

b. Cardiovascular system

1. Minimal changes in HR, BP, and cardiac output. Often chosen to induce general anesthesia in hemodynamically compromised patients.
2. Does not affect the sympathetic tone or the baroreceptor function.

c. Respiratory system

1. Dose-dependent decreases in respiratory rate(RR) and tidal volume(TV); transient apnea may occur.
2. The respiratory depressant effects of etomidate are less pronounced than those of propofol or barbiturates.

4. Dosage and administration.

Etomidate for induction IV 0.2-0.5mg/kg

5. Adverse effects

- a. Myoclonus** may occur after administration, particularly in response to stimulation.
- b. Nausea and vomiting** occur more frequently in the postoperative period than with other anesthetic agents.
- c. Venous irritation and superficial thrombophlebitis** may be caused by the propylene glycol vehicle. Minimized by administration into a free-flowing IV carrier infusion.
- d. Adrenal suppression.** Inhibits 11 β -hydroxylase; a single induction dose suppresses adrenal steroid synthesis for up to 24 hours. May not be a clinically significant problem after a single dose, but repeated doses or infusions have been associated with increased mortality in ICU patients.

D. Ketamine

A sedative-hypnotic agent with potent analgesic properties. It is used for the induction of general anesthesia and for sedation and analgesia in the perioperative setting.

1. Mode of action. Anesthetic effects are mainly attributed to noncompetitive antagonism of NMDA receptors in the CNS, although effects on opioid receptors, acetylcholine receptors, and voltage-gated sodium and calcium channels also have been reported.

2. Pharmacokinetics

- a. Produces unconsciousness in 30 to 60 seconds after an IV induction dose. Effects are terminated by redistribution in 15 to 20 minutes. After intramuscular (IM) administration, the onset of CNS effects is delayed for approximately 5 minutes, with peak effect at approximately 15 minutes.
- b. Metabolized rapidly in the liver to multiple metabolites, some of which have modest activity (e.g., norketamine). Elimination half-life is 2 to 3 hours.
- c. Repeated bolus doses or prolonged infusions result in accumulation.

3. Pharmacodynamics

a. CNS

- 1. Produces a “dissociative” state accompanied by amnesia and profound analgesia. Analgesia occurs at much lower concentrations than hypnosis, so analgesic effects persist after the return of consciousness.
- 2. Increases cerebral blood flow (CBF), cerebral metabolic rate, and intracranial pressure; cerebral vasoconstriction in response to hyperventilation is preserved.
- 3. Dose-dependent EEG changes that differ from other anesthetics; high doses do not produce an isoelectric EEG.

b. Cardiovascular system

- 1. Increases HR, cardiac output, and BP of systemic and pulmonary arteries by causing the release of endogenous catecholamines.
- 2. Often used to induce general anesthesia in hemodynamically compromised patients, particularly those for whom heart rate, preload, and afterload should remain high.
- 3. May act as a direct myocardial depressant in patients with maximal sympathetic nervous system stimulation or in patients with autonomic blockade.

c. Respiratory system

- 1. Usually depresses respiratory rate (RR) and tidal volume (TV) only mildly and has minimal effect on CO₂ response.
- 2. Potent bronchodilator due to sympathomimetic effects.
- 3. Laryngeal protective reflexes are relatively well maintained, although aspiration can still occur.

4. Dosage and administration.

Ketamine for induction IV 1-2mg/kg

IM 3-5mg/kg

N.B. Useful for IM induction in patients with no IV access (e.g., children).

5. Adverse effects

- a. **Oral secretions** are markedly stimulated. The coadministration of an antisialagogue (e.g., glycopyrrolate) may be helpful.
- b. **Emotional disturbance.** May cause agitation and unpleasant hallucinations during the early postoperative period. Incidence is higher with increased age, female gender, and dosages greater than 2 mg/kg but may be greatly reduced with the coadministration of a benzodiazepine or propofol. Children seem to be less troubled than adults by the hallucinations. Alternatives should be considered in patients with psychiatric disorders.
- c. **Muscle tone.** May lead to random myoclonic movements, especially in response to stimulation. Muscle tone is often increased.
- d. **Increases ICP** and is relatively contraindicated in patients with head trauma or intracranial hypertension.
- e. **Ocular effects.** May lead to mydriasis, nystagmus, diplopia, blepharospasm, and increased intraocular pressure; alternatives should be considered during ophthalmologic surgery.

E. Dexmedetomidine.

Dexmedetomidine is a sedative agent with analgesic properties. It is used as an adjunct to general and regional anesthesia and for sedation in the ICU and the OR.

1. **Mode of action.** Highly selective α_2 -adrenergic receptor agonist. **Clonidine** is a less-selective and longer-acting α_2 agonist with similar sedating and analgesic properties.
2. **Pharmacokinetics**
 - a. Undergoes rapid redistribution after IV administration. Elimination half-life is approximately 2 hours.
 - b. Metabolized extensively in the liver.
3. **Pharmacodynamics**
 - a. **CNS**
 1. Elicits a sedated but arousable state similar to natural sleep.
 2. Potentiates CNS effects of propofol, volatile anesthetics, benzodiazepines, and opioids.
 3. Weak amnestic; no anticonvulsant properties.

b. Cardiovascular system

1. Decreases HR and BP, although transient hypertension may occur after an IV bolus.
2. Baroreflex is well preserved.

c. Respiratory system

1. Minimal respiratory depression, although it may add to respiratory depressant effects of other anesthetics.
2. Airway reflexes remain intact, making it useful for awake fiber-optic intubation.

4. Dosage and administration.

- a. Intravenous infusion of dexmedetomidine is commonly initiated with a 1 $\mu\text{g}/\text{kg}$ loading dose, administered over 10 minutes, followed by a maintenance infusion of 0.2–1.0 $\mu\text{g}/\text{kg}/\text{hour}$
 - b. Decreased dosage should be considered in patients with significant hepatic dysfunction.
- 5. Adverse effects.** Antimuscarinic effects (e.g., dry mouth and blurred vision) may occur due to α_2 adrenal receptor-mediated inhibition of acetylcholine release.

F. G. Opioids.

Morphine, meperidine, hydromorphone, fentanyl, sufentanil, alfentanil, and remifentanil are opioids commonly used in general anesthesia. Their primary effect is analgesia, and, therefore, they are used to supplement other agents during the induction or maintenance of general anesthesia. In high doses, opioids are occasionally used as the primary anesthetic (e.g., cardiac surgery). Opioids differ in their potencies, pharmacokinetics, and side effects.

1. **Mode of action.** Bind to specific receptors in the brain, spinal cord, and on peripheral neurons. The opioids listed above are all relatively selective for μ -opioid receptors.

2. Administration of opioids

- a. There are multiple routes of administration, including oral, parenteral, intramuscular, neuraxial, transdermal, and transmucosal.

b. Parenteral administration**Distribution**

1. Onset and duration of action depend on the **lipid solubility** and **ionization** of the drug.
2. Drugs diffuse across the blood–brain barrier and redistribute to inactive tissue sites such as skeletal muscle and fat.
3. High doses of lipid soluble drugs (i.e., fentanyl) lead to saturation of inactive sites and buildup of the drug in the plasma, resulting in a longer duration of action.

ii. Metabolism

1. Most opioids are metabolized in the liver and excreted by the kidney.
2. An exception is **remifentanyl**, which is rapidly metabolized by **plasma esterases**.
3. Many opioids have **long-acting, pharmacologically active metabolites**.
 - i. **Normeperidine is the active metabolite of meperidine** and has renal elimination. Its accumulation can cause seizures and should be used with caution in patients with renal failure.
 - b. **Morphine-6-glucuronide is an active metabolite of morphine** and can accumulate in neonates and those with renal failure.
3. Special considerations and drug interactions
 - i. Meperidine should be avoided in patients with renal failure, history of seizures, and those taking monoamine oxidase inhibitors.
 - ii. The combination of monoamine oxidase inhibitors and meperidine can result in a severe reaction including fever, convulsions, hemodynamic instability, and coma.
 - b. **Naloxone is a specific opiate receptor antagonist**, binding the receptor without causing activation.
 - c. The effective dose is **1 to 4 µg/kg IV**, and the duration of action is **30 to 45 minutes**.
 - i. Dose **may need to be repeated** or an **infusion** started (**5 µg/kg/h**) after administration of a long-acting opiate.
 - d. **Side effects** of naloxone
Reversal of analgesia, nausea, vomiting, and increased sympathetic nervous system activity, including tachycardia, hypertension, pulmonary edema, and cardiac dysrhythmias.

3. PHARMACOLOGICAL ACTIONS OF OPIOID AGONISTS

Central Nervous System

- i. · Analgesia:
- ii. · Sedation: Drowsiness.
- iii. · Euphoria and dysphoria: Morphine and other opioids cause a sense of contentment and well-being (euphoria). If there is no pain, morphine may cause restlessness and agitation (dysphoria).
 - **Tolerance and Dependence:** Tolerance is the decrease in effect seen despite maintaining a given concentration of a drug. The mechanism is not fully understood but could involve down regulation of opioid receptors or decreased production of endogenous opioids. Dependence exists when the sudden withdrawal of an opioid, after repeated use over a prolonged period, results in

various physical and psychological signs. These include; restlessness, irritability, increased salivation, lacrimation and sweating, muscle cramps, vomiting and diarrhoea.

Cardiovascular System

- Mild bradycardia is common as a result of decreased sympathetic drive and a direct effect on the sino-atrial (SA) node.
- Peripheral vasodilatation caused by histamine release and reduced sympathetic drive may result in a slight fall in blood pressure that may be significant in hypovolaemic patients.

Respiratory System

- Respiratory depression is mediated via MOP receptors at the respiratory centres in the brainstem. Respiratory rate falls more than the tidal volume and the sensitivity of the brain stem to carbon dioxide is reduced.
- Opioids suppress cough.

Gastrointestinal System

- Stimulation of the chemoreceptor trigger zone causes nausea and vomiting. Smooth muscle tone is increased but motility is decreased resulting in delayed absorption, increased pressure in the biliary system (spasm of sphincter of Oddi) and constipation.

Endocrine System

- The release of ACTH, prolactin and gonadotrophic hormone is inhibited. Secretion of ADH is increased.

Ocular effects

constriction of the pupils (meiosis).

Histamine release and itching

- Some opioids cause histamine release from mast cells resulting in urticaria, itching, bronchospasm and hypotension. Itching occurs most often after intrathecal opioids and is more pronounced on the face, nose and torso. Mechanism is centrally mediated and may be reversed by naloxone.

Muscle rigidity

- Large doses of opioids may occasionally produce generalised muscle rigidity especially of thoracic wall and interfere with ventilation.

Immunity

- The immune system is depressed after long-term opioid abuse.

Effects on Pregnancy and Neonates

- All opioids cross the placenta and if given during labour, can cause neonatal respiratory depression.

- Chronic use by the mother may cause physical dependence in utero and lead to a withdrawal reaction in the neonate at birth that can be life threatening.

- There are no known teratogenic effects.

4. Adverse effects of opioid use include:

- i. Nausea and vomiting: The use of opioids stimulates opioid receptors present in the gastrointestinal tract as well as in the vomiting centre of the brain to cause nausea and vomiting.
- ii. Drowsiness or sedation: Opioids, and in particular morphine, are known to cause severe sedation and drowsiness.
- iii. Skin changes: An allergic reaction called urticaria may develop and cause a skin rash characterized by red, itchy, raised bumps. This is caused by the release of histamine in response to opioid use.
- iv. Miosis:
- v. Constipation: Opioids cause sluggish peristaltic movements in the digestive tract.
- vi. Respiratory depression.
- vii. Changes in heart rate: Heart rate may become either rapid or very slow.
- viii. Spasms: Some people may develop spasms of the ureter and urinary retention or biliary colic and spasms of the biliary tree.
- ix. Myoclonus: This describes muscle rigidity and abnormal movement of the limbs and muscles. This can occur with the use of high doses.
- x. Dependence and likelihood of abuse: Long term opioid use may cause dependence on the drugs, leading to withdrawal syndrome if they are abruptly discontinued.

5. Specific agents

2. Morphine

Morphine may be a poor choice in patients with renal failure due to accumulation of morphine-6-glucuronide metabolites.

- a. Morphine is the most commonly used and most commonly studied opioid in the United States.
- b. Morphine is metabolized in the liver
 - i. Principal metabolites include morphine-3-glucuronide and morphine-6-glucuronide.
 - ii. These metabolites are excreted by the kidneys. Morphine 6-glucuronide is an active metabolite possessing sedating and analgesic properties
- iii. Therefore, **morphine may be a poor choice for a patient with renal failure.**

3. Fentanyl

- a. Fentanyl is a synthetic opioid and anywhere from 80 to 125 times more potent than morphine .
- b. It is metabolized in the liver to inactive metabolites which are excreted in the urine .
- i. 10 mcg of fentanyl would equal 1,000 mcg (1 mg) of morphine.

4. Meperidine

- a. Meperidine is seven to ten times *less* potent as compared morphine .
- b. Meperidine's **mechanism of action is at opioid receptors but it also possesses some antagonist activity at NMDA receptors** .
- c. In addition, meperidine inhibits norepinephrine (NE) and serotonin reuptake .
- d. Meperidine is metabolized in the liver .
- i. An active metabolite, normeperidine is formed which relies on renal excretion .
- ii. Normeperidine lowers the seizure threshold.

Meperidine should be used with caution in patients with renal failure or seizure disorders or in those who are taking monoamine oxidase inhibitors.

5. ULTIVA (remifentanyl hydrochloride)

- a. ULTIVA (remifentanyl) is for IV use only. Continuous infusions should be administered only by an infusion device.
- b. Remifentanyl undergoes widespread extrahepatic metabolism by blood and tissue nonspecific esterases, resulting in an extremely rapid clearance

INHALED ANESTHETIC AGENTS

Inhaled anesthetic agents include nitrous oxide (the oldest of all anesthetics) and various halogenated agents: desflurane (halogenated solely with fluorine—halogenation increases potency and is essential to ensure nonflammability), halothane (halogenated with fluorine, chlorine, and bromine), isoflurane (halogenated with fluorine and chlorine), and sevoflurane (halogenated solely with fluorine). Halothane was the first fluorinated inhaled anesthetic that was

wildly successful, rapidly displacing all other potent inhaled anesthetics. Efforts to develop other halogenated anesthetics with more of the characteristics of the ideal inhaled anesthetic agent than halothane led to the introduction of isoflurane, desflurane, and sevoflurane.

Characteristics of the ideal inhaled anesthetic agent:

- Ample potency,
- Low solubility in blood and tissues,
- Resistance to physical and metabolic degradation,
- A protective effect in and lack of injury to vital tissues.
- The lack of a propensity to cause seizures, respiratory irritation, and circulatory stimulation;
- A low acquisition cost.
- Allowing the use of a high concentration of oxygen.

The minimum alveolar concentration (MAC) of an anesthetic agent at one atmosphere that abolishes movement in response to a noxious stimulus in 50% of subjects provides the standard definition of inhaled anesthetic potency. In 30– 60 year-old patients, MAC values for halothane, isoflurane, sevoflurane, and desflurane are 0.75%, 1.15%, 1.85%, and 6.0% at one atmosphere, respectively, which indicates that they all are potent and can be given with a high concentration of oxygen.

By contrast, the MAC for nitrous oxide is 104% at one atmosphere, and it must be given in a pressurized chamber due to safety considerations.

Solubility of an anesthetic agent in blood is quantified as the blood:gas partition coefficient, which is the ratio of the concentration of an anesthetic in the blood phase to the concentration of the anesthetic in the gas phase when the anesthetic is in equilibrium between the two phases. For example, the partition coefficient is 0.5 if the concentration of an anesthetic in arterial blood is 3% and the concentration in the lungs is 6%. A low blood:gas partition coefficient reflects a low affinity of blood for the anesthetic, a desirable property because it predicts a more precise control over the anesthetic state and a more rapid recovery from anesthesia. The blood:gas partition coefficients for inhaled anesthetics vary from a low of about 0.45 for nitrous oxide and desflurane and 0.65 for sevoflurane to 1.4 for isoflurane and 2.4 for halothane.

A. Mode of Action

1. **Nitrous oxide.** Although exact mechanisms are unknown, anesthetic effects are mainly attributed to the antagonism of NMDA receptors in the CNS.
2. **Volatile anesthetics.** Exact mechanisms are unknown. Various ion channels in the CNS involved in synaptic transmission (including GABA_A, glycine, and glutamate receptors) have been shown to be sensitive to inhalation anesthetics and may play a role.

B. Pharmacokinetics

1. **Determinants of the speed of onset and offset.** The alveolar anesthetic concentration (F_A) may differ significantly from the inspired anesthetic concentration (F_I). The rate of rise of the ratio of these two concentrations (F_A/F_I) determines the speed of induction of general anesthesia. Two opposing processes, anesthetic delivery to and uptake from alveoli, determine the F_A/F_I at a given time. Determinants of uptake include the following:

- a. **Blood-gas partition coefficient.** A lower solubility in blood will lead to lower uptake of anesthetic into the bloodstream, thereby increasing the rate of rise of F_A/F_I . The solubility of halogenated volatile anesthetics in blood is increased somewhat with hypothermia and hyperlipidemia.
 - b. **Inspired anesthetic concentration.** This is influenced by the volume of the breathing circuit, fresh gas inflow rate, and the absorption of the volatile anesthetic by circuit components.
 - c. **Alveolar ventilation.** Increased minute ventilation, without the alteration of other processes that affect anesthetic delivery or uptake, increases F_A/F_I . This effect is more pronounced with the more blood-soluble agents.
 - d. **Concentration effect.** As F_I increases, the rate of rise of F_A/F_I also increases. For a gas with a high F_I like nitrous oxide, a large amount is taken up into blood, but this causes a large loss of the total gas volume. The remaining nitrous oxide is thus “concentrated,” and the addition of more anesthetic with the next breath will increase the concentration further. The uptake of a large gas volume also creates a void that draws more fresh gas into the alveoli, thereby increasing F_A and augmenting the inspired tidal volume. The concentration effect explains why the rate of rise of F_A/F_I is faster for nitrous oxide than for desflurane, even though the blood-gas partition coefficient for desflurane is smaller.
 - e. **The second gas effect.** This is a direct outcome of the concentration effect. When nitrous oxide and a potent inhalation anesthetic are administered together, the uptake of nitrous oxide concentrates the “second” gas (e.g., isoflurane) and increases the input of additional second gas into the alveoli via the augmentation of inspired volume.
 - f. **Cardiac output.** An increase in the cardiac output (and therefore pulmonary blood flow) will increase anesthetic uptake and thus decrease the rate of rise in F_A/F_I . A decrease in the cardiac output will have the opposite effect. This effect of cardiac output is more pronounced with non-rebreathing circuits or highly soluble anesthetics and is most prominent early in the course of anesthetic administration.
2. **Distribution in tissues.** The rate of equilibration of anesthetic partial pressure between blood and a particular organ system depends on the following factors:
- a. **Tissue blood flow.** Equilibration occurs more rapidly in tissues receiving increased perfusion. The **vessel-rich group** of highly perfused organ systems receives approximately 75% of the cardiac output. The remainder of the cardiac output perfuses predominantly into muscle and fat.
 - b. **Tissue solubility.** For a given arterial anesthetic partial pressure, anesthetic agents with high-tissue solubility are slower to equilibrate. Solubilities of anesthetic agents differ among tissues.

- c. **Gradient between arterial blood and tissue.** Until equilibration is reached between the anesthetic partial pressure in the blood and a particular tissue, a gradient exists that leads to the uptake of anesthetic by the tissue. The rate of uptake will decrease as the gradient decreases.

3. Elimination

- a. **Exhalation.** This is the predominant route of elimination. After discontinuation, an anesthetic's tissue and alveolar partial pressures decrease by reversing the processes that occurred when the anesthetic was introduced.
- b. **Metabolism.** Significant biotransformation of nitrous oxide has not been demonstrated. Volatile anesthetics may undergo different degrees of hepatic metabolism.
- c. **Anesthetic loss.** Inhalation anesthetics may be lost both percutaneously and through visceral membranes, although such losses are probably negligible.

C. Pharmacodynamics

1. Nitrous oxide

a. CNS

1. Produces analgesia.
2. Because of its high MAC (104%), it is usually combined with other anesthetics to attain surgical anesthesia.

b. Cardiovascular system

1. Mild myocardial depressant and a mild sympathetic nervous system stimulant.
2. HR and BP are usually unchanged.
3. May increase pulmonary vascular resistance in adults.

- c. **Respiratory system.** Mild respiratory depressant, although less so than the volatile anesthetics.

2. Volatile anesthetics

a. CNS

1. Produce unconsciousness and amnesia at relatively low inspired concentrations (25% to 35% of MAC).
2. Dose-dependent depression of EEG activity up to and including burst suppression.
3. Increase cerebral blood flow (CBF) and uncouple autoregulation of CBF.

b. Cardiovascular system

1. Produce dose-dependent myocardial depression and systemic vasodilation.
2. HR tends to be unchanged, although desflurane can cause sympathetic stimulation, tachycardia, and hypertension at induction or when the inspired concentration is abruptly increased.

3. Sensitize the myocardium to the arrhythmogenic effects of catecholamines, which is of particular concern during the infiltration of epinephrine-containing solutions or the administration of sympathomimetic agents.

c. Respiratory system

1. Produce dose-dependent respiratory depression with decrease in tidal volume (TV), increase in respiratory rate (RR), and increase in arterial CO₂ pressure.
2. Produce airway irritation and, during light levels of anesthesia, may precipitate coughing, laryngospasm, or bronchospasm, particularly in patients who smoke or have asthma. The lower pungency of sevoflurane makes it more suitable for use as an inhalation induction agent.
3. Equipotent doses of volatile agents possess similar bronchodilator effects, with the exception of desflurane, which has mild bronchoconstricting activity.
4. Inhibit hypoxic pulmonary vasoconstriction, which may contribute to pulmonary shunting.

d. Neuromuscular system

1. Dose-dependent decrease in skeletal muscle tone, often enhancing surgical conditions.
2. May precipitate **malignant hyperthermia** in a susceptible patient.

e. Hepatic system. May cause a decrease in hepatic perfusion. Rarely, a patient may develop hepatitis secondary to exposure to a volatile agent, most notably halothane (“halothane hepatitis”).

f. Renal system. Decrease renal blood flow through either a decrease in mean arterial pressure (MAP) or an increase in renal vascular resistance.

D. Adverse Effects Related to Specific Agents

1. Nitrous oxide

- a. Expansion of closed gas spaces.** The predominant constituent in closed gas-containing spaces in the body is nitrogen. Because nitrous oxide is 35 times more soluble in blood than nitrogen, closed air spaces will expand as the amount of nitrous oxide diffusing into these spaces is greater than the amount of nitrogen diffusing out. Spaces containing air such as a pneumothorax, occluded middle ear, bowel lumen, or pneumocephalus will markedly enlarge if nitrous oxide is administered. Nitrous oxide will diffuse into the cuff of an endotracheal tube and may increase pressure within the cuff.
- b. Diffusion hypoxia.** After discontinuation of nitrous oxide, its rapid elimination from the blood into the lung may lead to a low partial pressure of oxygen in the alveoli, resulting in hypoxia and hypoxemia if supplemental oxygen is not administered.

NEUROMUSCULAR BLOCKADE

A. DEPOLARIZING NEUROMUSCULAR BLOCKADE (PHASE I BLOCKADE) occurs when a drug mimics the action of the neurotransmitter acetylcholine (ACh).

Succinylcholine (SCh) (called also, Suxamethonium), which structurally represents two molecules of acetylcholine (ACh) linked together via the acetyl moieties, activates the acetylcholine receptors (AChR) leading to depolarization of the postjunctional membrane. Because Succinylcholine (SCh) is not degraded as quickly as ACh, persistent endplate depolarization inactivates sodium channels and makes them resistant to subsequent stimulation by ACh.

Induction doses of SCh produce the rapid onset (about 1 minute) of a transient agonist effect (e.g., muscle twitch) followed by skeletal muscle paralysis lasting 4 to 6 minutes. These characteristics make SCh a common choice for facilitating rapid tracheal intubation.

Depolarizing blockade is characterized by

- a. Transient muscle fasciculations followed by relaxation.
- b. Acetylcholine esterase (AChE) inhibitors potentiate rather than reverse the block.
 2. SCh effect terminates when the drug diffuses away from the AChRs and is rapidly hydrolyzed by **plasma cholinesterase** (produced in the liver and also referred to as pseudocholinesterase) to succinylmonocholine and then, more slowly, to succinic acid and choline. This enzyme is not the same as AChE and is not found in the synaptic cleft. However, inhibitors of AChE affect both enzymes to different degrees.
 3. **Side effects of Succinylcholine (SCh)** are related to its agonist effects at both the nicotinic and muscarinic AChRs.
 - a. **Myalgia** is common postoperatively, especially in the muscles of the abdomen, back, and neck. It is attributed to muscle fasciculations and observed more frequently in females and younger patients after minor surgical procedures.
 - b. **Cardiac dysrhythmias.** SCh has no direct effect on the myocardium. SCh may also produce sinus bradycardia, junctional rhythm, and even asystole after the first dose in children and following repeated exposure within a short time interval (i.e., 5 minutes) in adults. Pretreatment with intravenous (IV) atropine immediately before SCh reduces the occurrence of bradyarrhythmias.
- c. SCh depolarization exaggerates the usual transmembrane ionic flux and normally induces elevation of serum potassium by 0.5 to 1.0 mEq/L. However, life-threatening **hyperkalemia** and cardiovascular collapse may occur in patients with major burns, massive tissue injuries, extensive denervation of skeletal muscle, or upper motor neuron diseases.

- d. A transient **increase in intraocular pressure** occurs 2 to 4 minutes following SCh, presumably due to fascicular contractions of the extraocular muscles with associated compression of the globe.
 - e. **Increased intragastric pressure** results from fasciculations of abdominal muscles.
 - f. SCh produces a mild transient **increase in intracranial pressure**.
 - g. **A history of malignant hyperthermia (MH) is an absolute contraindication to the use of SCh.** Some degree of masseter muscle spasm may be a normal response to SCh, but severe jaw rigidity increases the risk that a fulminant MH episode may follow. Generalized muscle rigidity, tachycardia, tachypnea, and profound hyperpyrexia after SCh should alert the clinician to this condition .
 - h. **Succinylcholine apnea (Prolonged blockade)** following SCh may be caused by low levels of plasma cholinesterase as in severe liver or kidney disease, a drug-induced inhibition of its activity, or a genetically atypical enzyme.
 - i. **Phase II block.** This may occur after large or repeated doses of suxamethonium. Neuromuscular block is prolonged
 - j. **Anaphylaxis.** Suxamethonium is responsible for over 50% of anaphylactic reactions to NMBDs.
- B. NONDEPOLARIZING BLOCKADE** is produced by reversible competitive antagonism of ACh at the subunits of the AChRs.
1. It is characterized by the following:
 - a. Absence of fasciculations.
 - b. Potentiation by other nondepolarizing NMBDs and volatile anesthetic agents.
 - c. Reversal by AChE inhibitors.
 2. **Mivacurium** is a short-acting nondepolarizing NMBD composed of three stereoisomers (trans–trans, cis–trans, and cis–cis diesters). It is rapidly hydrolyzed by plasma cholinesterase. It should be used with caution in patients with known atypical plasma cholinesterase activity or using cholinesterase inhibitors. Histamine release can occur with rapid administration of higher doses causing a transient decrease of systemic blood pressure and tachycardia. If blockade following mivacurium must be reversed with an anticholinesterase agent, edrophonium may be preferred to neostigmine because it has much less effect on plasma cholinesterase activity.
 3. **Atracurium** is a mixture of 10 stereoisomers. The drug undergoes ester hydrolysis by nonspecific plasma esterases and Hofmann elimination (nonbiologic process independent of renal, hepatic, or enzymatic function). Laudanosine, its major metabolite, is a CNS stimulant at high plasma levels. Atracurium is recommended for patients with significant hepatic or renal disease. Rapid IV

administration at doses greater than 2.5 times the ED₉₅ causes a transient release of histamine and hypotension.

4. **Cisatracurium** is one of 10 stereoisomers that constitute atracurium. It is approximately four times as potent as atracurium. High molar potency results in a relatively slow onset time. The drug is cleared primarily by Hoffman degradation, and its duration of action is largely independent of renal or hepatic function. Unlike atracurium, it does not produce histamine release or hemodynamic effects after rapid injection of doses as high as eight times its ED₉₅.
5. **Vecuronium** is a lipophilic nondepolarizing neuromuscular blocking drug that is readily absorbed by the liver and excreted into the bile. One of the metabolites, 3-desacetylvecuronium, has neuromuscular blocking properties (about 50% to 70% of the potency of vecuronium) and eliminated by the kidneys. Vecuronium has a prolonged clinical effect in elderly patients and those with liver disease and renal failure, as a result of reduced clearance and extended elimination half-life. Vecuronium has no significant effects on heart rate and blood pressure, but it inhibits histamine *N*-methyltransferase and might potentiate effects such as flushing and hypotension when histamine is released by drugs such as morphine.
6. **Rocuronium** is an analog of vecuronium that has lower potency. The large intubating dose results in a fast onset time because a larger number of molecules reach the neuromuscular junction NMJ per circulation time. At a dose of 0.6 mg/kg, good to excellent intubating conditions are achieved within 60 seconds. Increasing the dose to 1.2 mg/kg shortens the time even more but significantly prolongs the duration of action, which can be highly variable among patients. This drug is often chosen when a rapid sequence induction is required but SCh is contraindicated. Clearance of rocuronium occurs as unchanged drug in bile and through renal excretion. Administration of the drug to patients with renal failure could result in a longer duration of action, especially after repeated doses or continuous infusion. Rocuronium does not induce the release of histamine or produce cardiovascular effects, even after administration of large doses.
7. **Pancuronium** is a long-acting nondepolarizing neuromuscular blocking drug. It is predominantly eliminated by the kidneys, and it has a prolonged duration of neuromuscular blockade in patients with renal failure. In patients with hepatic cirrhosis or biliary tract dysfunction, the initial dose of pancuronium to achieve adequate relaxation may be higher due to increased volume of distribution, whereas the duration of action is greater than usual due to decreased plasma clearance. Pancuronium can increase systemic blood pressure, heart rate, and cardiac output by inhibition of catecholamine reuptake at sympathetic nerve terminals and a vagolytic action at cardiac muscarinic receptors.

C. Clinical Choice of NMBD

1. **Many factors** must be considered simultaneously when selecting neuromuscular blocking drugs NMBDs: the urgency for tracheal intubation, the duration of the procedure, coexisting medical conditions that may affect the NMJ, and side effects and metabolism of the drug. For example, the rapid onset of SCh makes it a good choice for rapid intubation of the trachea, but rocuronium will decrease the risk of hyperkalemia in patients with burns. Pancuronium can produce a tachycardia that is undesirable in patients with severe ischemic heart disease, but its vagolytic effects may be appropriate in pediatric patients.
2. **Cost-effectiveness** is also a consideration in the choice of drug. The additional expense of newer short-acting NMBDs may not be justified in longer cases. On the other hand, the incidence of postoperative residual blockade and costs of postoperative drug-induced morbidity should be part of assessing cost-effectiveness.

C. Anticholinesterases

- Anticholinesterases (also known as acetylcholinesterase inhibitors) are agents that inhibit the action of the acetylcholinesterase enzyme at the neuromuscular junction. Enzyme inhibition leads to a reduction in the breakdown of ACh and potentiates its action.
- Anticholinesterases are used in anaesthesia to reverse the effects of non-depolarizing NMBDs which usually occurs at the end of surgery, and should not take place before some resolution of the block has already occurred. If peripheral nerve stimulation is used, at least 3 twitches on a train of four should be detected before attempting reversal. The most reliable sign that a block is fully reversed by anticholinesterase is a sustained response to tetanic stimulation with a peripheral nerve stimulator (i.e. no fade).
- Clinical tests of adequate resolution of neuromuscular block include the ability to lift the head from the bed for 5 seconds, although this is a much less reliable assessment.
- There is no role for anticholinesterases in reversing the effects of suxamethonium.

Anticholinesterase drugs

- **Neostigmine.** The most commonly used anticholinesterase in anaesthesia. This is a water-soluble quaternary ammonium compound that combines reversibly with the esteratic site of the acetylcholinesterase enzyme rendering it inactive for about 30 minutes. Neostigmine is given as an intravenous injection at a dose of 0.05 mg/kg (maximum 5mg), and should be administered with glycopyrronium 0.01 mg/kg or atropine 0.02 mg/kg. Neostigmine starts to

take effect after approximately 2 minutes but has its maximal effect at 5-7 minutes. It is excreted unchanged by the kidney and has a half-life of about 45 minutes.

- **Edrophonium.** Edrophonium is rarely used to reverse the effects of NMBDs as its effects are short lived . Edrophonium is used as a diagnostic test for the neuromuscular disease myasthenia gravis.
- **Pyridostigmine.** This agent has a longer onset than neostigmine and lasts for several hours. It is used more frequently as a therapy for myasthenia gravis.
- **Physostigmine.** Like neostigmine and pyridostigmine, physostigmine acts reversibly at the esteratic site of the acetylcholinesterase enzyme.

References

1. Stoelting RK, Hiller SC. *Pharmacology and Physiology in Anesthetic Practice*. Philadelphia, PA: Lippincott Williams & Wilkins; 2006.
2. Coda BA. Opioids. In: Barash PG, Cullen BF, Stoelting RK, Cahalan MK, Stock MC, eds. *Clinical Anesthesia*. 6th ed. Philadelphia,

Anesthesia OSCE 2015

045 Anesthesia team



Index

Topic	Page
Preoperative assessment	
• A) Definition of preoperative period.	3
• B) Indications of preoperative evaluation.	3
• C) Evaluation of a patient in the pre-operative period:	3
I. History taking.	4
II. Examination.	6
III. ASA Classification.	6
IV. Investigations.	6
V. Consent.	6
VI. Premedication.	6
VII. Preoperative starvation.	6
Airway management	
• A) Basic airway anatomy	7
• B) Methods of supporting the airway:	
I. Mouth-to-mask ventilation with supplemental oxygen.	8
II. Bag mask ventilation.	9
III. Laryngeal Mask Airway (LMA).	10
IV. Endotracheal Tube (ETT).	12
V. Fiber-optic laryngoscope.	14
VI. Instruments that ease the process of intubation.	15
• C) Rapid sequence induction	16
• D) Difficult Airway management	17
• E) Surgical Invasive airway access	18
Regional Anesthesia	
• A) Definition of regional anesthesia.	19
• B) Indications of regional anesthesia.	19
• C) Contraindications of regional anesthesia.	19
• D) Complications of regional anesthesia.	19
• E) Types of regional anesthesia.	
I. Epidural anesthesia.	20
II. Spinal anesthesia.	21
III. Combined spinal and epidural anesthesia.	22
Intravenous Access	
• A) Central line:	23
• B) Peripheral veins:	25
Intravenous Fluids	
• A) Factors must be taken into account	27
• B) Crystalloids.	27
• C) Colloids.	27
• D) Fluid replacement.	27
• E) Blood loss regimens.	29
• F) Blood transfusion complications.	29

Preoperative Care

A) Definition of preoperative period:

It is the time from the decision to have surgery until admitted into the OR theatre.

B) Indications of preoperative evaluation:

1. Assess the anesthetic risks in relation to the proposed surgery.
2. To decide the anesthetic technique (general, regional, or a combination).
3. To plan the postoperative care including any analgesic regimens.

C) Evaluation of a patient in the pre-operative period:

I. History taking:

1. Introduction:

- Introduce yourself to the patient giving your name and status as a student. Ask for permission to take a history and perform a physical examination.

2. Personal history:

Ask for the patient's name, age, occupation, nationality, and marital status.

3. Present illness:

Establish the principal symptom or symptoms that caused the patient to seek medical attention, when it first appeared and how it has changed over time.

4. Past medical:

Ask about the patient's previous medical problems including cardiac (IHD, HTN, HF, AF), respiratory (asthma, COPD, TB), neurological (stroke, TIA, epilepsy), gastroenterological (liver disease, jaundice) and haematological (sickle cell, thalassemia) problems. Also ask the patient if they are pregnant if relevant.

5. Past surgical:

Ask about any previous operations and post-op. complications. Enquire about previous types of anaesthesia received (local, general) and enquire about any anesthetic complications (malignant hyperthermia).

6. Medications:

Ask about any prescribed medications the patient is taking including insulin or hypoglycemics, anticoagulants (warfarin, aspirin), β -blockers, steroids, ACE inhibitors, diuretics and inhalers. Enquire about any over-the-counter medication, contraception (COCP) and HRT.

7. Allergies:

Enquire about allergies to antibiotics, plasters, latex, eggs and antiseptic solutions.

8. Family history:

Check for family history of any illnesses including myotonic dystrophy, malignant hyperpyrexia, porphyria, cholinesterase disorders and sickle cell disease. Enquire about any other anaesthetic complications and allergic reactions in the family.

9. Dental:

Ask about any history of dental problems, false teeth, caps, bridges and dentures.

10. Social:

Elicit the patient's alcohol history noting the number of units consumed in a week. Determine if the patient is a smoker and how many cigarettes he smokes per day.

Anesthesia OSCE

I. Complete review of the systems

Traumatic:	Infection	Inflammatory	Neoplastic	Endocrine:	Pregnancy
<ul style="list-style-type: none">• Fractures Of Mandible And Cervical Spine	<ul style="list-style-type: none">• Epiglottitis• Dental Or Facial Abscess	<ul style="list-style-type: none">• Ankylosing Spondylitis• Rheumatoid Arthritis	<ul style="list-style-type: none">• Tongue• Neck• Mouth	<ul style="list-style-type: none">• Thyroid Enlargement• Acromegaly• Obesity	

Important Symptoms that you should ask in the history:

- Upper airway obstruction may be found in patients with stridor, dysphagia and hoarseness.
- Snoring may also indicate partial upper airway obstruction.

II. Examination:

Initially examine the patient generally then move to airway examination.

1. General examination:

- BMI: Measure the patient's height and weight and calculate his body mass index. Ideal BMI is between 18.5 and 24.9.
- Document the patient's blood pressure, oxygen saturation on air, pulse, respiratory rate and temperature.
- Perform a brief chest, abdomen, cardiovascular and neurological examination.

2. Airway: (LEMON)

• Look:

- Ask the patient to flex and extend his neck and to open and close his mouth looking for short immobile neck. Some patients cannot be placed in the "sniffing position" secondary to neck trauma, cervical collar, musculoskeletal disorders like kyphosis and rheumatoid arthritis.
- A neck circumference of greater than 45cm in an obese patient with a BMI of greater than 40kg/m^2 is likely to be a difficult intubation.
- Women with large pendulous breasts add a degree of difficulty to an intubation because the provider may not be able to position the blade handle appropriately toward the chest
- Inspect the mouth and see if there are any obvious abnormalities, buckteeth, high arch palate, receding mandible (may be hidden by a beard), Inability to sublux the jaw (forward protrusion of the lower incisors beyond the upper incisors).

• Evaluate:

a. Thyromental distance:

- It is the distance from the thyroid cartilage to the mental prominence when the neck is extended fully.
- If the distance is more than 7cm (around 3 fingerbreadths), problems

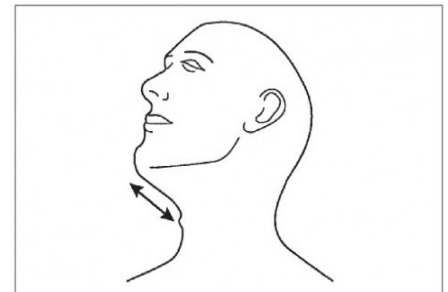

Figure 1.2 Line shows the thyromental distance from the thyroid cartilage to the tip of the chin.

Anesthesia OSCE

should not occur with intubation.

- A distance of less than 6 cm suggests laryngoscopy will be impossible and for distances of 6–6.5 cm, laryngoscopy is considered difficult, but possible.

b. Sternomandibular distance:

- This test is claimed to predict up to 90% of difficult intubations.

- The distance from the upper border of the manubrium sterni to the tip of the chin, with the mouth closed and the head fully extended, is measured.

- A distance of less than 12.5 cm indicates a difficult intubation.

c. Alantooceptal joint:

- Presence of a gap between the Occiput and C1 is essential.

- It should be (15-20 degrees).

d. C-Spine:

- Flexion and extension of the head and neck must be more than 90 degree.

e. Intradental gap:

- Normal interdental gap is 3 fingers.

- Poor mouth opening: less than three fingers gap between upper and lower teeth.

- **Mallampatti score:**

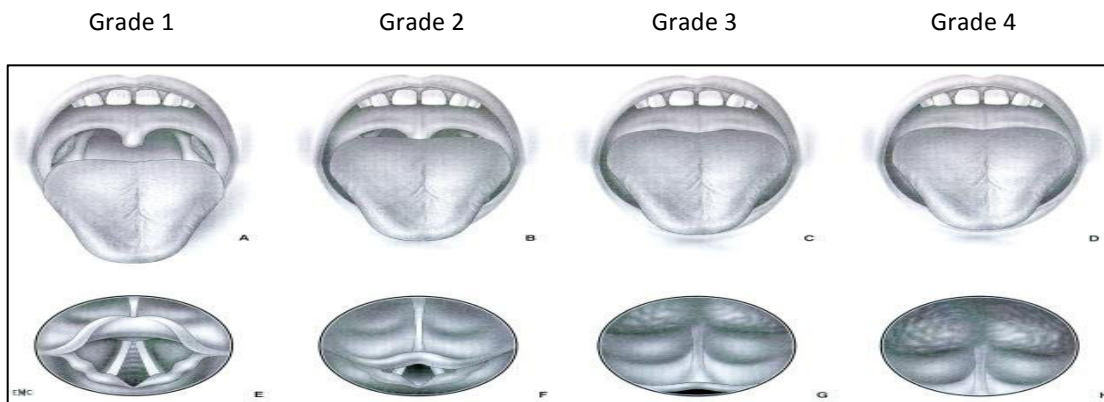

Mallampatti score (preoperative)	Laryngeal view scoring system (intraoperative)
Grade 1: facial pillars, soft palate and uvula visible	Grade 1: all the glottis (opening between the vocal cord) is visible
Grade 2: facial pillars, soft palate visible, but uvula masked by the base of the tongue	Grade 2: only the posterior portion of the glottis is visible
Grade 3: soft palate only visible	Grade 3: only the epiglottis is visible
Grade 4: soft palate not visible	Grade 4: even the epiglottis is not visible
Patients in Grades 3 and 4 are considered difficult to intubate and those in Grades 1 and 2 are considered feasible intubations. It is important to realize That this system is <i>not</i> infallible and patients in Grade 2 sometimes cannot be intubated.	

Anesthesia OSCE

- **O**bstruction:
Airway edema, tracheal mass, mediastinal mass.
- **N**eck mobility.

III. ASA classification

- ASA 1: Healthy patient without organic biochemical or psychiatric disease.
- ASA 2: A Patient with mild systemic disease. No significant impact on daily activity. Unlikely impact on anesthesia and surgery.
- ASA 3: Significant or severe systemic disease that limits normal activity. Significant impact on daily activity. Likely impact on anesthesia and surgery.
- ASA 4: Severe disease that is a constant threat to life or requires intensive therapy. Serious limitation of daily activity.
- ASA 5: Moribund patient who is equally likely to die in the next 24 hours with or without surgery.
- ASA 6: Brain-dead organ donor.
- "E" – added to the classifications indicates emergency surgery.

IV. Investigations:

State that you would order investigations if clinically appropriate.

- **Blood:**
Hemoglobin concentration.
Coagulation profile.
Screening for sickle cell disease.
Urea.
Creatinine.
Electrolytes.
Glucose.
- **Chest X- ray.**
Respiratory (asthma, COPD) or cardiac disease (heart failure), malignancy, thoracic surgery, respiratory symptoms (cough, SOB, sputum), previous TB.
- **ECG.**
Hypertension, heart disease, arrhythmia, >50 years old, DM.

V. Consent:

It should be a written one and it explains the anesthetic options for a given surgical procedure.

VI. Premedication:

If your patient need any premeditations like anxiolytics mention them.

VII. Preoperative starvation:

- From Solid Food = 6-8 hours.
- From Clear Fluid= 2 hours.
- From Breast Milk for Neonates = 4 hours.
- From Formula Milk for Neonates = 6 hours.

Airway management

A) Basic airway anatomy:

I. Normal anatomy:

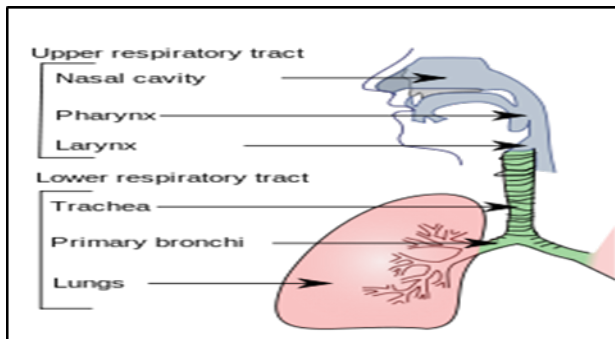

II. Upper Airway:

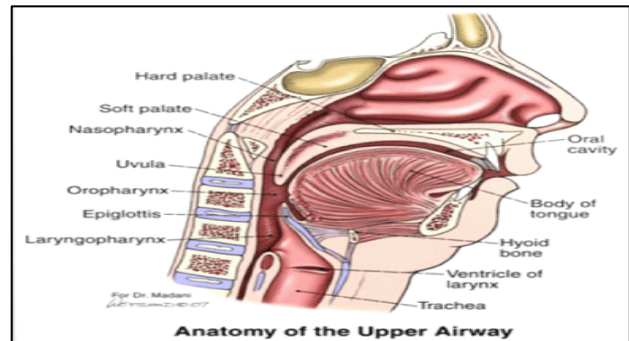

III. Vocal cords:

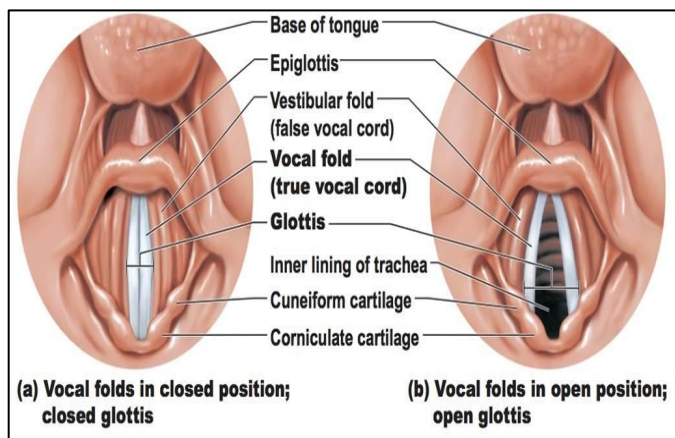

IV. Lower airway:

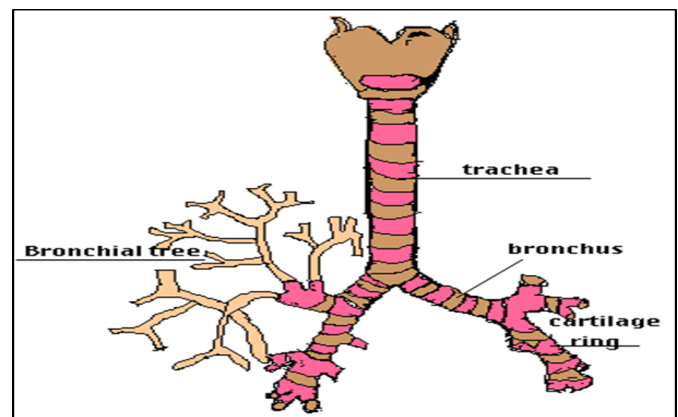

Right bronchus is wider, shorter, and more vertical in direction than the left. So aspiration occurs more into the right bronchus.

B) Methods of supporting the airway:

- I. Mouth-to-mask ventilation with supplemental oxygen.
- II. Bag mask ventilation.
- III. Laryngeal Mask Airway (LMA).
- IV. Endotracheal Tube (ETT).
- V. Fiber-optic laryngoscope.
- VI. Instruments that ease the process of intubation.

Anesthesia OSCE

I. Mouth to mask ventilation Supplemental Oxygen:

- **Indications:** Patients who are unresponsive, apneic, or have depressed respirations.
- **Contraindications:** None when above conditions apply.
- **Complications:** Gastric distention.
- **Equipment:** (see pictures)



- **Procedure steps:**

Performance Steps of Mouth to mask ventilation	✓ if done Correctly
Connect oxygen line with 10 - 15 L flow.	
Establish airway by head-tilt, chin lift.	
Insert Oropharyngeal airway with proper technique.	
Establish seal with mask.	
Ventilate mouth-to-mask.	

Anesthesia OSCE

II. Bag mask Ventilation

- **Advantages:** basic, Non-invasive, Readily available, Can use oropharyngeal/ nasopharyngeal airway.
- **Disadvantages:** Risk of aspiration if decreases LOC, Cannot ensure airway Patency, Inability to deliver precise tidal volume, Operator fatigue.
- **Indications:**
 - Failure of ventilation
 - Failure of oxygenation
 - Failed intubation
- **Contraindications:**
 - Severe facial trauma.
 - Bag mask ventilation is absolutely contraindicated in the presence of complete upper airway obstruction. So, Foreign material in the airway should be removed before bag mask ventilation is initiated.
 - It is relatively contraindicated after paralysis and induction (because of the increased risk of aspiration).
- **Complications:**
 - The main complications of the bag-mask technique are inability to ventilate and gastric inflation.
- **Equipment:**
 - Bag-valve-mask.
 - Oxygen connector tubing.
 - Oxygen source.
 - Suction.
 - Nasal pharyngeal airway (NPA).
 - Oral pharyngeal airway (OPA).
- **Procedure steps:**



Performance Steps of Bag mask Ventilation	√ if done Correctly
Perform head tilt-chin lift.	
Perform suctioning within 10 seconds.	
Assembles bag and chooses appropriate size mask.	
Choose appropriate size OPA (Oropharyngeal Airway) or NPA (Nasopharyngeal Airway) and Inserts device.	
Hold and seal mask with 1 hand.	
Ventilate at proper rate (1 breath every 5 to 6 seconds).	
Produce noticeable chest rise.	
Deliver each ventilation over 1 second.	
Release bag completely between ventilations.	
Hold and seals mask correctly with 2 hands.	
Apply cricoid pressure.	

III. Laryngeal Mask Airway (LMA) intubation:

- **Advantages:**

- Easy to insert. (Emergency situations)
- Less airway trauma/irritation than ETT.
- Frees up hands (vs. face mask)
- Primarily used in spontaneously ventilating patient.

- **Disadvantages:**

- Does NOT protect against laryngospasm or gastric aspiration.

- **Sizes:**

- 40-50 kg: 3
- 50-70 kg: 4
- 70-100 kg: 5

- **Indications:**

- The laryngeal mask airway (LMA) is an acceptable alternative to mask anesthesia in the operating room.
- It is often used for short procedures when endotracheal intubation is not necessary.

- **Contraindications:**

Absolute contraindications: (in all settings, including emergent)

- Cannot open mouth.
- Complete upper airway obstruction.

Relative contraindications: (in the elective setting):

- Anyone with increased risk of aspiration. (Morbid obesity, second or third trimester pregnancy, patients who have not fasted before ventilation, and upper gastrointestinal bleed.)
- Prolonged bag-valve-mask ventilation.
- Suspected or known abnormalities in supraglottic anatomy.
- Need for high airway pressures (in all but the LMA ProSeal, pressure cannot exceed 20 mm H₂O for effective ventilation.)

- **Complications:**

Complications due to LMA insertion:

- Aspiration of gastric contents.
- Local irritation.
- Upper airway trauma.
- Pressure-induced lesions.
- Nerve palsies.
- Mild sympathetic response.

Complications associated with improper placement:

- Obstruction.
- Laryngospasm.

Complications associated with positive pressure ventilation:

- Pulmonary edema.
- Bronchoconstriction.



Anesthesia OSCE

- Performance Steps Of Laryngeal Mask Airway:**

Performance Steps Of Laryngeal Mask Airway:	√ if done correctly
Prepare and assemble all necessary equipment.	
Choose appropriate size LMA.	
Test integrity of cuff by inflating it.	
Deflate cuff on a flat surface and lubricate LMA on posterior surface only for use.	
Open the mouth using the "crossed fingers" technique or by performing a tongue-jaw lift; do not hyperextend neck.	
Clear the airway if needed.	
Insert tube into mouth and place it so that the curvature is the same as that of the Pharynx, directing it posteriorly until resistance is felt.	
Inflate the cuff with the appropriate amount of air corresponding to the size of the tube, remove syringe.	
Insert bite block.	
Produce noticeable chest rise; auscultate breath sounds.	
Confirm correct positioning of LMA by colorimetric ETCO ₂ capnograph.	
Secure LMA in place.	
Perform correct ventilation rate for respiratory arrest (1 breath every 5 to 6 seconds).	
Perform correct ventilation rate for cardiac arrest (1 breath every 6 to 8 seconds).	
Deliver each ventilation over 1 second.	
Demonstrate complete release of bag between ventilation.	

IV. Endotracheal tube (ETT) intubation:

- **Advantages: (The 5 Ps)**
 - Ensures airway Patency
 - Protects against aspiration
 - Allows Positive pressure ventilation
 - Allows suctioning i.e. "Pulmonary toilet"
 - A route for pharmacological administration.
- **Disadvantages:**
 - Insertion can be difficult.
 - Muscle relaxants usually needed.
 - Laryngospasm may occur on failed intubation or extubation.
 - Sympathetic stress due to Intubation.
- **Sizes:**
 - Male: 8.0-9.0 mm
 - Female: 7.0-8.0 mm
 - Pediatric: (age/4) + 4 mm
- **Indications:**
 - To ensure airway patency in an unconscious patient.
 - To protect the lungs from the aspiration of gastric contents.
 - To provide positive-pressure ventilation, in the setting of respiratory failure or of general anesthesia.
- **Contraindications:**
 - Any situation where the pharynx is obstructed (pharyngeal foreign body, massive swelling of the pharynx), or if there is serious maxillofacial trauma.
- **Complications:**
 - An endotracheal tube that is mistakenly sized or misplaced, especially in the apneic patient, can quickly lead to hypoxia and death.
 - Accidental intubation of the esophagus.
 - Oropharyngeal trauma.
 - Broken teeth or dentures.
 - Endobronchial intubation, ETT inserted too far.



Laryngoscope

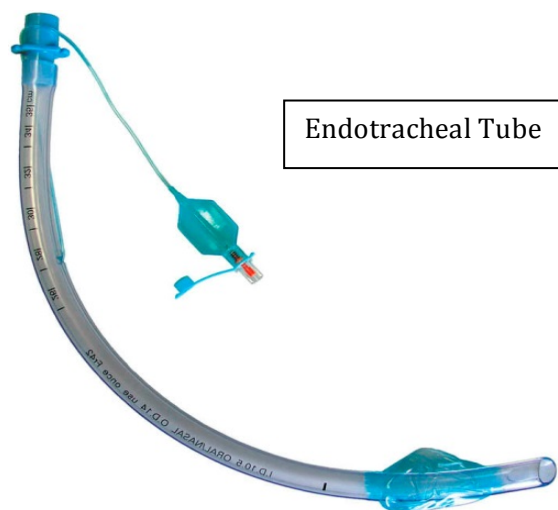

Endotracheal Tube

Anesthesia OSCE

- **Performance Steps Of Adult Intubation using ETT:**

Performance Steps Of Adult Intubation	√ If done correctly
Assume ventilation is in progress.	
Assemble and checks all necessary equipments	
Choose appropriate size ET tube	
Choose appropriate type (straight or curved) and size laryngoscope blade	
Check light ,Tests ET tube cuff integrity	
Insert the stylet and lubricates the ET tube	
Place head in neutral or sniffing position	
Clear airway if needed	
Insert laryngoscope blade	
Hold laryngoscope in left hand.	
Insert laryngoscope in right side of mouth, moving tongue to the left.	
Visualize epiglottis, then vocal cords.	
Insert ET tube to proper length for gender	
Inflate ET tube cuff to achieve proper seal; remove syringe	
Insert bite block	
Produce noticeable chest rise; auscultates breath sounds	
Confirm correct positioning of ET tube by colorimetric ETCO ² Capnograph	
Secure ET tube in place (commercial device or tape)	
Perform correct ventilation rate for respiratory arrest (1 breath every 5 to 6 seconds)	
Perform correct ventilation rate for cardiac arrest (1 breath every 6 to 8 Seconds)	
Deliver each ventilation over 1 second	
Demonstrate complete release of bag between ventilations	

V. Fiberoptic laryngoscope intubation:

Fiberoptic endotracheal intubation is a useful technique in a number of situations. It can be used when the patient's neck cannot be manipulated, as when the cervical spine is not stable. It can also be used when it is not possible to visualize the vocal cords because a straight-line view cannot be established from the mouth to the larynx. Fiberoptic intubation can be performed either awake or under general anesthesia and it can be performed either as the initial management of a patient known to have a difficult airway, or as a backup technique after direct laryngoscopy has been unsuccessful.

It is usually done if there was any thyroid enlargement.

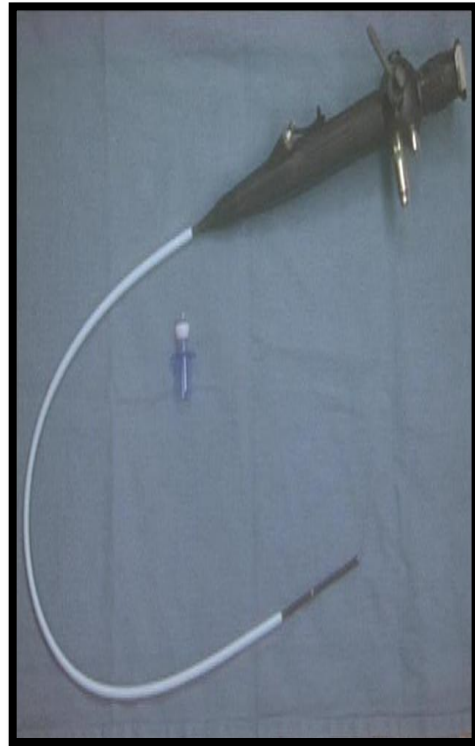
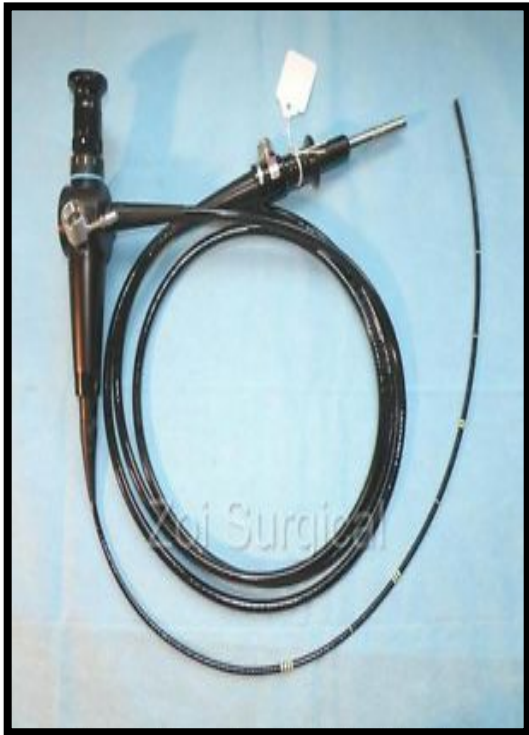

VI. Instruments that ease the process of intubation:

- **Glidescope:**

Indications:

- Patients with poor direct laryngoscopic view.
- Obese patients.
- Challenging airways (inability to view the vocal cords on direct view) due to anatomic variation or distortion.
- Small mouth opening (< 3 cm)
- Limited neck extension.
- Excessive secretions in the airway. (The GlideScope has an anti-fogging heat lamp to enable views in the presence of excess/bloody secretions)

Contraindications:

- Absolute Contraindications: None.
- Relative Contraindications: may be overlooked in the true emergency situation because it is more important to resuscitate.
 - Limitations to mouth opening (< 3 cm)
 - Major trauma/fractures to the face (maxilla, mandible) or neck.
 - Neck abscess (retropharyngeal) can cause difficulty with tracheal intubation.
 - Neoplasm of the upper airway that may distort airway anatomy.
 - Nasal intubation required for surgical procedure (e.g., oral surgery)

- **Lighted Stylet:**

Endotracheal stylet with a light source at the tip. Very helpful in intubation aid, especially in difficult airways. The light can be seen from outside the patient helping guide the ET tube through the vocal cords.

- **Bougie:**

- Flexible device around 60 cm long.
- Used in Bougie-assisted Endotracheal Intubation.



← Lighted stylet

Intubation using bougie →

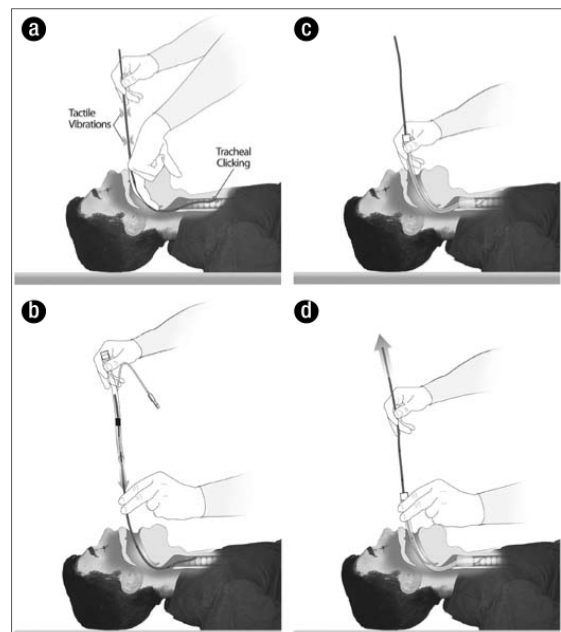

Anesthesia OSCE

C) Rapid sequence induction:

- **Indications:**
 - When the patient has “full stomach”, i.e. predisposed to regurgitation/aspiration.
 - Decrease level of consciousness (LOC).
 - Trauma.
 - Meal within 6 hours.
 - Sphincter incompetence suspected (GERD, hiatus hernia, nasogastric tube).
 - Increased abdominal pressure (pregnancy, obesity, bowel obstruction, acute abdomen).
 - Used in short procedures as well.
- **Procedure steps:**

Performance Steps Of Rapid sequence induction	√ If done correctly
Pre-oxygenate/denitrogenate: patient breaths 100% O ₂ for 3-5 minutes.	
Apply ECG monitor, BP monitor, pulse oximeter	
Secure intravenous access.	
Test ET tube and all equipment necessary for intubation.	
Assistant performs Sellick's maneuver: pressure on cricoid cartilage to compress esophagus between cartilage and C6 to prevent	
Administration of induction agent immediately followed by fast acting muscle relaxant (e.g. succinylcholine).	
Intubate shortly after administration of muscle relaxant (approximately 45-60 seconds) with no bag-mask ventilation in between induction and intubation.	
Inflate cuff ETT to prevent aspiration of gastric contents.	
Verify correct placement of ETT.	
Release cricoid cartilage pressure	
Confirm correct positioning of ET tube	
Ventilate when ETT in place and cuff inflated.	
Estimate patient's weight.	
Calculate drug dosages and draw up into syringes.	
Intraoperative fluid management.	
Exubation.	
Recovery.	

Anesthesia OSCE

D) Difficult Airway management:

Pre operative assessment is very helpful in expecting a difficult airway case. It helps us in planning the management of intubation (Plan A, Plan B and so on). However not all difficult airways are detected by the preoperative assessment. Asking the patient if he had previous difficult intubation, doing an airway examination. **Not every previously successful intubated patient means easy airway.** Pre oxygenation is very important in these cases to give the patient a good reservoir. Intubation should be done within 30 seconds.

The first step after failed intubation is calling for help.

Then we can do either:

- Awake intubation
- Intubation with Lighted stylet (trachlight), fiberoptic laryngoscope, or Glidscope.

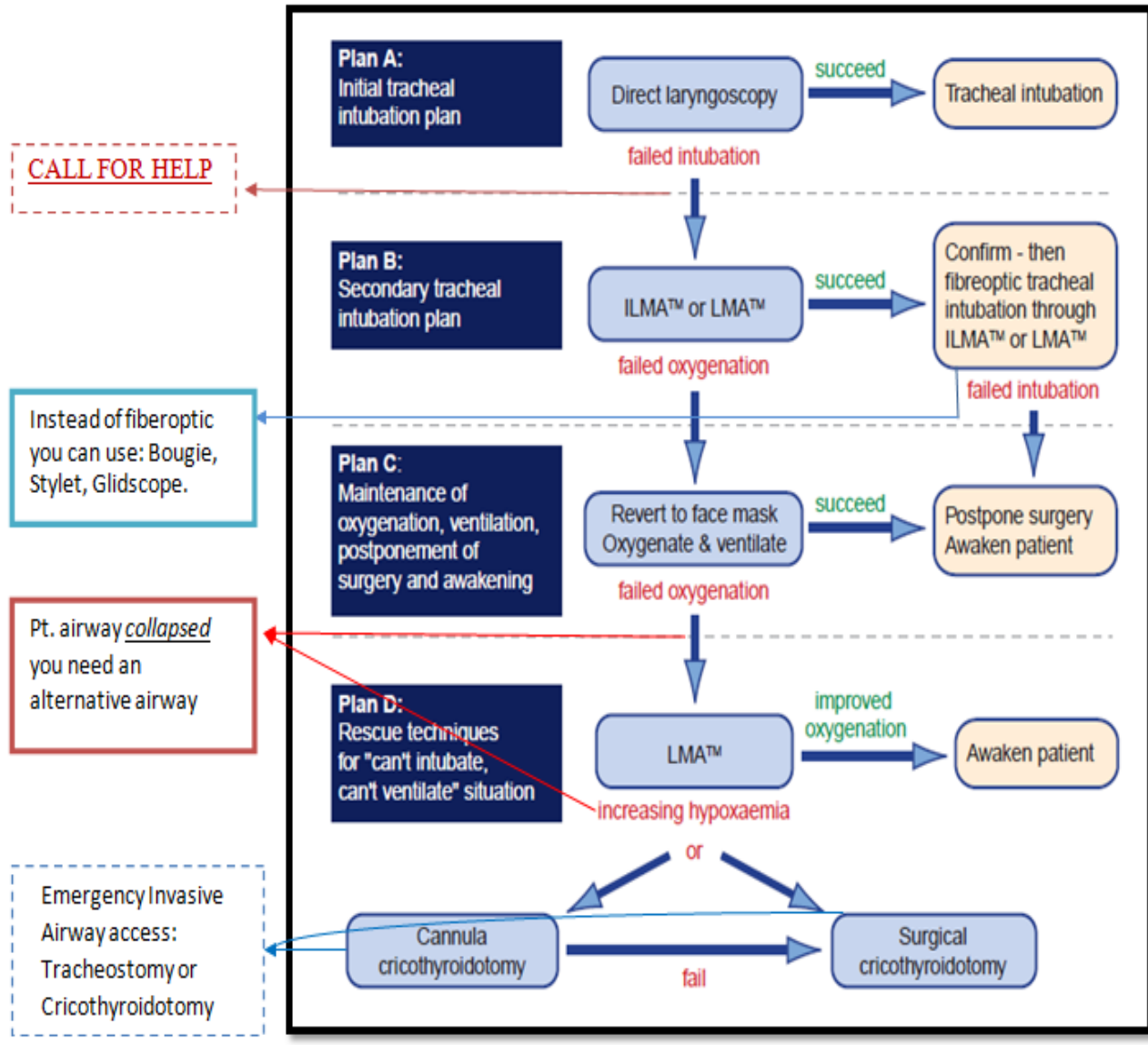

E) Surgical Invasive airway access:

I. Tracheostomy:

It is made by direct access to the trachea through the neck. After the incision is made surgically you place a tracheostomy tube to maintain the opening. Can be done in acute and chronic (elective) situations.

- Indications:
 - Obstruction of the upper airway, eg foreign body, trauma, infection, laryngeal tumor, facial fractures.
 - Impaired respiratory function, eg head trauma leading to unconsciousness, bulbar poliomyelitis.
 - To assist weaning from ventilatory support in patients on intensive care.
 - To help clear secretions in the upper airway.

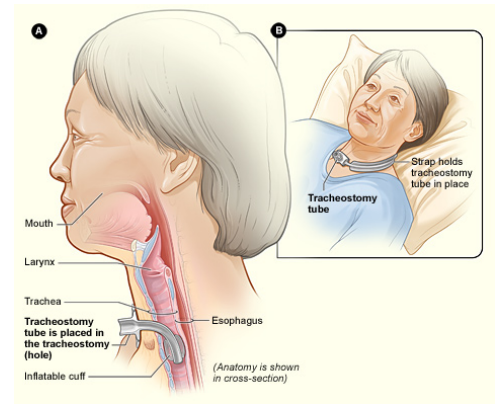

II. Cricothyrotomy:

Provides a temporary emergency airway in situations where there is obstruction at or above the level of the larynx (Nose & Mouth). Quick, easy and far less complications than tracheostomy. Can be done by needle, with purpose-built kits intubation, surgically, and even with penknife and straws.

- Indications:
 - Need for an emergency airway where:
 - Intubation is not possible via the oral or nasal route.
 - Severe maxillofacial trauma.
 - Oedema of throat tissues preventing visualization of the cords (eg angioneurotic oedema, anaphylaxis, burns, smoke inhalation).
 - Severe oropharyngeal/tracheobronchial haemorrhage.
 - Foreign body in upper airway.
 - Lack of equipment for endotracheal intubation.
 - Technical failure of intubation.
 - Severe trismus/clenched teeth.
 - Masseter spasm after succinylcholine.
- Contraindications:
 - Availability of a less invasive means of securing the airway.
 - Patients <12 years old.
 - Laryngeal fracture.
 - Pre-existing or acute laryngeal pathology.
 - Anatomical landmarks obscured by gross haemorrhage/surgical emphysema, etc.

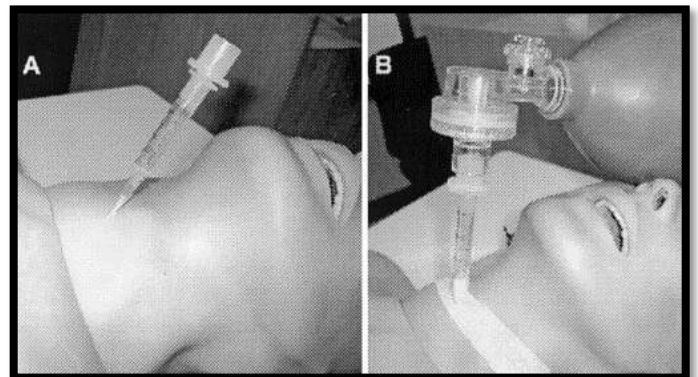

Regional Anesthesia

A) Definition of regional anesthesia:

Local anesthetic agent (LA) applied around a peripheral nerve at any point along the length of the nerve (from spinal cord up to, but not including, the nerve endings) for the purposes of reducing or preventing impulse transmission.

B) Indication of regional Anesthesia:

- Avoid some of the dangers of general anesthesia e.g. known difficult intubation, severe respiratory failure.
- Patient specifically requests regional anesthesia.
- High quality post-operative pain relief.
- General anesthesia not available/contraindication.
- Titration of LA dosage or differential blockade e.g. can block pain but preserve motor function.
- Obstetrical.
- Lower limbs surgery.
- Pelvic surgery.
- Lower trauma

C) Contraindication of regional Anesthesia:

- **Absolut contraindication:**
 1. Patient refused.
 2. Hematological diseases.
 3. Local infection at local site.
 4. Increase intracranial pressure.
 5. Allergy to local anesthesia
 6. Sepsis.
- **Relative contraindication:**
 1. Lack of resuscitation equipment
 2. Lack of IV access
 3. Anticoagulation drugs use
 4. Neurological diseases
 5. Low back pain
 6. Hypervolemia.

D) Complications of regional Anesthesia:

- Hypotension. (Treated with IV fluids)
- Temporary lower-extremity motor or sensory deficits. (Treat by lowering the rate or concentration.)
- Urine retention. (Treat with insertion of a catheter)
- Local anesthetic toxicity (neurotoxicity) (Treated with stopping infusion immediately)
- Respiratory insufficiency. (Treated with stopping infusion immediately, ABC [100% o2 call for help], assess spread and height of block, and then alternate your analgesia regimen)
- Headache (Dural puncture). (Symptomatic treatment and autologous blood patch)
- Infection.
- Nausea and vomiting.
- Intravenous placement of catheter
- Subdural placement of catheter.
- Hematoma.

E) Types of regional anesthesia:

I. Epidural Anesthesia:

- **Definition**
a form of regional anesthesia involving injection of a local anesthetic into the epidural space.
- **Identification of the epidural space:**
Several methods can be used to identify the epidural space. They include the following:
 - Loss of resistance to air or preservative-free normal saline.
 - Compression of a small air bubble in saline
 - Hanging drop technique
- **Equipment:**
 - sterile towels
 - sterile gloves
 - Tuohy needle either 16 or 18 gauge .It is 10 cm long: 8 cm of needle and 2 cm of hub. It is marked in centimeters and has a curved 'Huber' tip.
 - Epidural catheter has three holes The catheter is marked in centimeter gradations up to 20 cm.
 - The filter has a 0.2 μm mesh that stops the injection of particulate matter, such as glass, and bacteria into the epidural space.
- **Complications**
 - Penetration of a blood vessel.
 - Hypotension (nausea & vomiting).
 - Headache.
 - Back pain.
 - Intravascular catheterization.
 - Wet tap.
 - Infection.

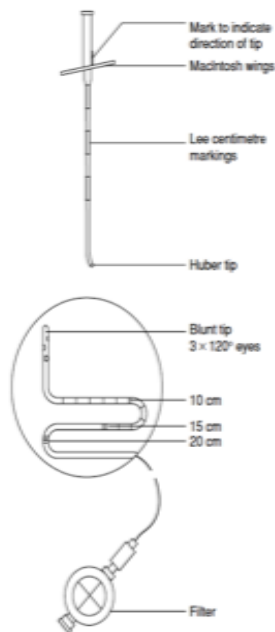
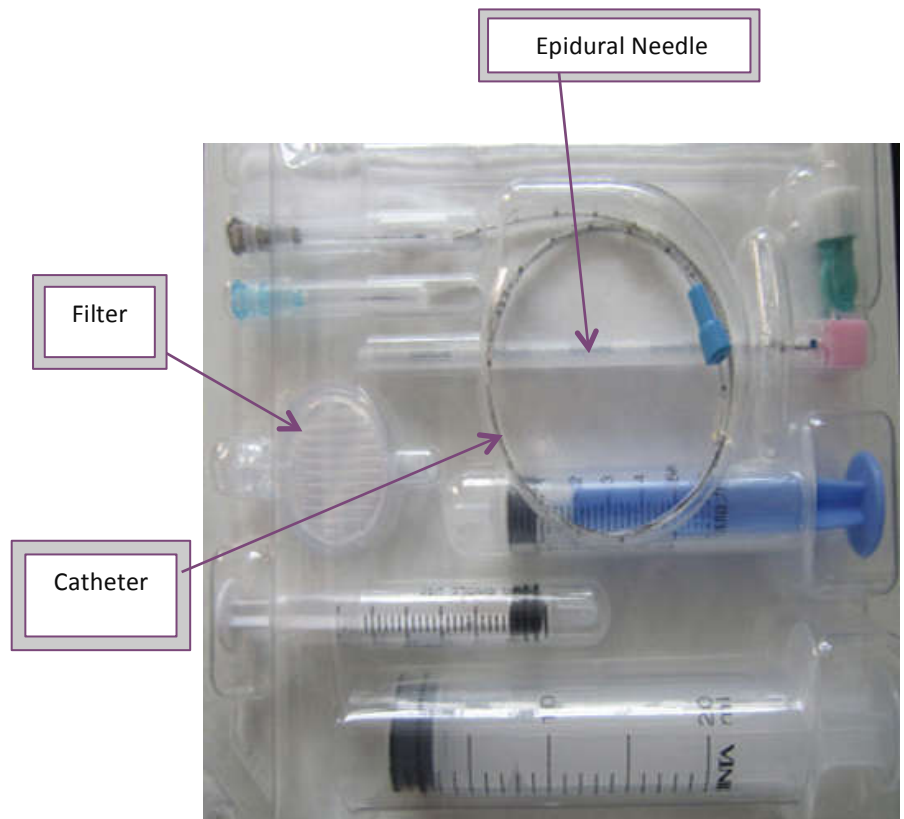

Figure Tuohy needle, epidural catheter and filter.



Anesthesia OSCE

II. Spinal Anesthesia:

- **Definition:**
a form of regional anesthesia involving injection of a local anesthetic into the subarachnoid space.
- **Identification of the subarachnoid space:**
Free flow of CSF confirms proper placement.
The spinal cord in adult begins from the foramen magnum and ends at L1 and in children L1 – L3.
- **Equipment:**
 - sterile towels.
 - sterile gloves.
 - sterile spinal needle.
 - an introducer needle if using a small gauge needle (this can be a sterile 19 gauge disposable needle)
 - sterile filter needle to draw up medications.
 - sterile 5 ml syringe for the spinal solution.
 - sterile 2 ml syringe with a small gauge needle to localize the skin prior initiation of the spinal anesthetic
 - antiseptics for the skin (such as betadine, chlorhexidine, methyl alcohol)
 - sterile gauze for skin cleansing and to wipe off excess antiseptic at needle puncture site
 - single use preservative free local anesthetic ampoule
- **Complications:**
 - Failed block
 - Back pain (most common)
 - Spinal head ache (More common in women ages 13-40, larger needle size increase severity, onset typically occurs first or second day post-op. Treatment: bed rest, fluid, caffeine, or blood patch)

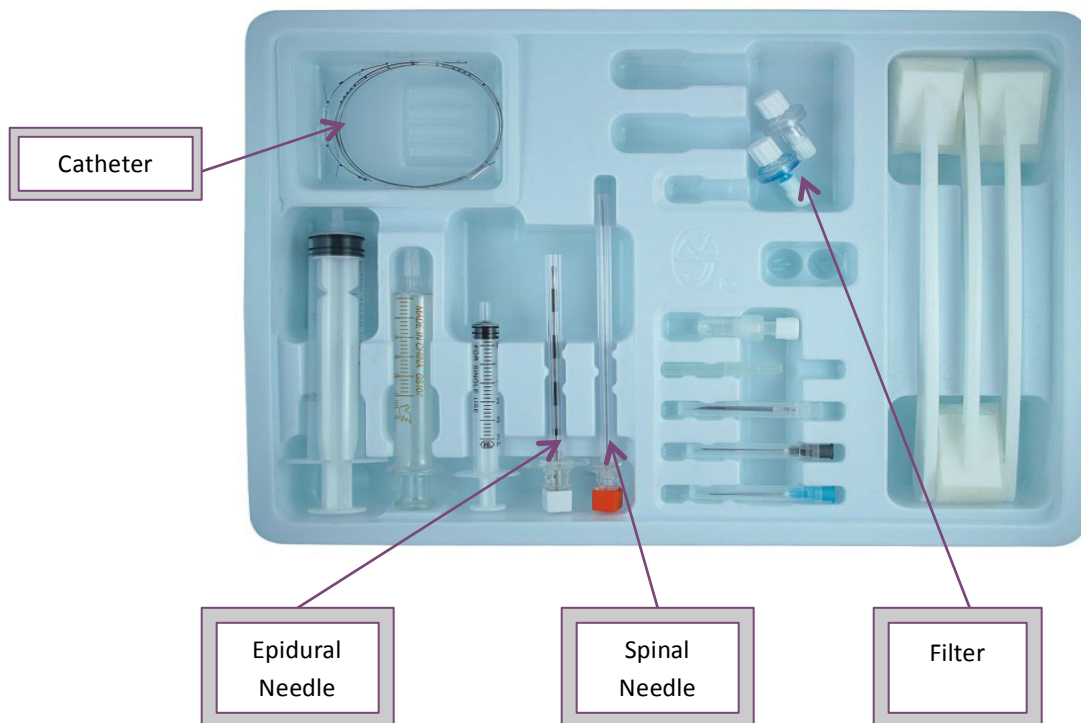

Anesthesia OSCE

- **Procedure steps:**

Performance Steps of spinal anesthesia	√ if done correctly
Taking Consent from the patient	
Assessment (indications and contraindications)	
Insert iv fluids	
Mask, cap, gown and gloves	
Prepare the back with antiseptic	
Place a sterile Drape Over The Area	
Identify the anatomical landmarks	
Inject local anaesthetic into the skin and deeper tissue	
Insert the large introducer needle into the selected spinal interspace	
Direct the spinal needle through the introducer and into the Subarachnoid space	
Free flow of CSF confirms proper placement	
Aspirate for CSF if clear inject the proper anaesthetic	
Remove the needle, introducer and drape sheet	
Have the patient lie down	

III. Combined spinal and epidural anesthesia:

- **Definition:**
Is a regional anesthetic technique, which combines the benefits of both spinal anesthesia and epidural anesthesia and analgesia. The spinal component gives a rapid onset of a predictable block. The indwelling epidural catheter gives the ability to provide long lasting analgesia and to titrate the dose given to the desired effect.
- **Indications:**
 - Caesarean sections.
 - Labor pains.
 - Post operative pain.

Intravenous access

A) Central line:

I. Indications:

- Monitor CVP
- Administration of fluids to treat hypovolemia and shock.
- Infusion of caustic drugs.
- Total parenteral nutrition
- Aspiration of air emboli
- Insertion of transcutaneous pacing leads
- Venous access in cases of poor peripheral veins.

II. Contraindications:

- Relative contraindicated in patients who are receiving anticoagulant.
- Ipsilateral carotid endarterectomy
- Injury, or infection at the site of insertion.

III. Complications:

- Local complications associated with femoral vein:
 - Thrombosis or phlebitis may extend to deep to iliac veins or vena cava.
 - Arterial cannulation – loss of limb.
 - Hematoma
- Local complications associated with subclavian and internal jugular:
 - Hematoma may compromise airway
 - Damage to adjacent artery, nerve, or lymphatic duct
 - Perforation of endotracheal cuff
- Systemic complications:
 - Pneumothorax. (Need follow-up chest X-ray)
 - Hemothorax.
 - Air embolism.
 - Infiltration into mediastinum or pleural space.
 - Arrhythmia from catheter tip.
 - Infection.

If pneumothorax is suspected treatment should not be delayed to confirm the diagnosis by chest x-ray.

- Maintain airway and ventilate with 100% oxygen.
- Insertion of 18G cannula at mid clavicular line, 2nd intercostal space or mid axillary line 5th intercostal space .
- Chest tube insertion should be arranged.

Chest x-ray demonstrating large right pneumothorax on the day after placement of the central venous catheter

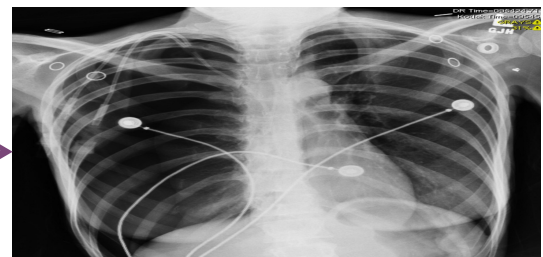

Anesthesia OSCE

IV. Procedure steps:

Performance steps of central line insertion:	Done correctly
Introduce yourself	
Greet the patient	
Explain procedure	
Assemble equipments	
Wash your hands and wear gloves	
Patient in supine, at least 150 head down position, head turned away	
Clean skin, use lidocaine if patient awake.	
Introduce needle attached to syringe in the center of triangle formed by two lower heads of sternomastoid muscle and clavicle	
Direct needle caudally, parallel to sagittal plane, at 300 posterior angle	
If vein not entered, withdraw needle and redirect it 5 to 10 degrees laterally	
Advance needle while withdrawing plunger of syringe	
When blood appears and vein entered, remove syringe and insert catheter to predetermined depth.	
Remove needle and connect catheter to IV tubing	
Cover puncture site, and affix catheter in place	
Documents procedure	
Ask the patient about any concerns	
Thank the patient	

V. Useful links:

<http://www.youtube.com/watch?v=YCOHP5-86K0>

<http://www.youtube.com/watch?v=4-uyTUzPSJ8>

Anesthesia OSCE

B) Peripheral veins :

I. Advantages:

- Effective route for drugs during CPR.
- Does not interrupt CPR.
- Easy technique.

II. Disadvantages:

- In circulatory collapse, vein may be absent.
- Access to central circulation may be difficult.
- Phlebitis common with saphenous vein.

III. Indications:

- Peripheral catheters are preferred when IV access is required for shorter periods, when direct access to the central circulation is unnecessary.
- Fluid maintenance.
- Fluid boluses for dehydration.
- Nutritional supplementation.
- Administration of medication.
- Blood transfusions.

IV. Contraindications:

- Trauma, injury, Burns extremities or infection site.
- Hematoma.
- Dialysis fistula.
- History of mastectomy.

V. Complications:

Infection, phlebitis, extravasation, infiltration, air embolism, hemorrhage (bleeding) and formation of a hematoma (bruise) may occur.

VI. Sites:

- Common:
 - Hands and arms.
 - Antecubital fossa.
- Alternative:
 - Long saphenous veins.
 - External jugular veins.



Anesthesia OSCE

VII. Procedure steps:

Performance Steps of peripheral vein cannulation	√ if done correctly
Introduce your self	
Greeting the patient	
Explain procedure and take consent	
Assemble equipment	
Inspect fluid for contamination, appearance, and expiration date	
Wash your hand and Put your gloves	
Apply tourniquet proximally.	
Locate vein and cleanse the overlying skin with alcohol or povidone- iodine.	
Anesthetize the skin if a large bore cannula is to be inserted in an awake patient.	
Hold vein in place by applying pressure on vein distal to the point of entry.	
Puncture the skin with bevel of needle upward about ½ to 1 centimeter from the vein and enter the vein either from the side or from above	
Note blood return and advance the catheter either over or through the needle, depending on which type of catheter-needle device is employed.	
Remove the tourniquet.	
Withdraw and remove the needle and attach the intravenous	
Documents procedure	
Ask the patient about any concerns	
Thanks the patient	

VIII. Useful link:

http://www.youtube.com/watch?v=w1SYOfzPWyg&oref=http%3A%2F%2Fwww.youtube.com%2Fwatch%3Fv%3Dw1SYOfzPWyg&has_verified=1

Intravenous fluids

A) Factors must be taken into account:

1. Maintenance fluid requirements.
2. NPO and other deficits: NG suction, bowel prep.
3. Third space losses.
4. Replacement of blood loss.
5. Special additional losses: diarrhea.

B) Crystalloid:

- Isotonic: electrolyte composition and osmolality similar to plasma: normal saline, Ringer`s Lactate
- Hypotonic: D5W
- Hypertonic (Fluids containing sodium concentrations greater than normal saline. Disadvantages: Hyponatremia, Hyperchloremia)
 - ◆ normal saline:
composition: Na, Cl.
Disadvantages: Hyper-chloremic acidosis
 - ◆ Lactated Ringer's:
MOST Physiological fluid
Composition: Na, Cl, K, Ca, lactate.
Disadvantages: Not to be used as diluent for blood (Ca citrate) and its low osmolality can lead to high ICP.

C) Colloids:

- Solutions stay in the space into which they are infused.
- Examples: hetastarch (Hespan), albumin, dextran.

D) Fluid replacement:

I. Maintenance fluid requirements:

- It is to maintain the insensible losses such as evaporation of water from respiratory tract, sweat, feces, and urinary excretion. Occurs continually.
- Adults: approximately 1.5 ml/kg/hr
"4-2-1 Rule"
 - 4 ml/kg/hr for the first 10 kg of body weight.
 - 2 ml/kg/hr for the second 10 kg body weight.
 - 1 ml/kg/hr subsequent kg body weight.
 - Extra fluid for fever, tracheotomy, endued surfaces.

Anesthesia OSCE

II. NPO and other deficits:

- NPO deficit = number of hours NPO x maintenance fluid requirement.
- Bowel prep may result in up to 1 L fluid loss.
- Measurable fluid losses, e.g. NG suctioning, vomiting, ostomy output, biliary fistula and tube.

III. Third space losses

It is the isotonic transfer of ECF from functional body fluid compartments to non-functional compartments.

Replacing Third Space Losses:

- Superficial surgical trauma: 1-2 ml/kg/hr
- Minimal Surgical Trauma: 3-4 ml/kg/hr
 - head and neck, hernia, knee surgery.
- Moderate Surgical Trauma: 5-6 ml/kg/hr
 - hysterectomy, chest surgery.
- Severe surgical trauma: 8-10 ml/kg/hr (or more)
 - AAA repair, nephrectomy.

IV Blood Loss:

- Replace 3 cc of crystalloid solution per cc of blood loss (crystalloid solutions leave the intravascular space).
- When using blood products or colloids replace blood loss volume per volume.

V. Other additional losses

Ongoing fluid losses from other sites:

- Gastric drainage.
- Ostomy output.
- Diarrhea.

Replace volume per volume with crystalloid solutions:

Anesthesia OSCE

E) Blood transfusion regimens:

	Platelets	FFB	Packed RBC	Whole Blood
Storage	Up to 5 days at 20-24° [warm]	at 18 degree or colder up to 12 months [cold]	4° for up to 42 days [cold]	4° for up to 35 days [cold]
Needs of warming	NO NEED	NEED	NEED	NEED
Needs of filter	NO NEED	NEED	NEED	NEED
Needs of ABO	NO NEED	NO NEED	NEED	NEED
Indication	<ul style="list-style-type: none"> • Thrombocytopenia & Plt (<15,000) • Bleeding and Plt (<50,000) • Invasive procedure and Plt (<50,000) 	<ul style="list-style-type: none"> • Coagulation Factor deficiency • fibrinogen replacement • DIC • liver disease • exchange transfusion • massive transfusion 	<ul style="list-style-type: none"> • mild bd loss • anemia & hypoxia to improve O₂ capacity 	<ul style="list-style-type: none"> • Massive Blood Loss • Trauma • Exchange Transfusion (e.g thalacemia)
Notes	<ul style="list-style-type: none"> • 1unit of platelet transfusion can increase platelet count up to 5000-10000 • Half life of platelets in the body 7days 	<ul style="list-style-type: none"> • There is a risk of virus transmitted disease • 1 unit of FFP can increase coagulation factor up to 2-3% • Given within 2 h of order 	<ul style="list-style-type: none"> • Usual dose (10 cc/kg) will increase Hgb by 2.5 gm/dl • Dose administration infusion (slowly) over 2-4 Hrs 	<ul style="list-style-type: none"> • Filter = 170 micro

F) Blood transfusion complications:

I. Immunological:

Pyrogenic.

Type 1 hypersensitivity.

Graft versus host reactions.

II. Biochemical:

- Acid base disturbances.

- Hyperkalemia.

- Citrate toxicity.

- Impaired oxygen release.

III. Infective.

IV. Hemolytic transfusion reaction.

V. Disseminated intravascular coagulation.

Anesthesia Cases 2015

Anesthesia
Cases
2015

2014

Anesthesia Cases

Your teacher presents you with a problem in anesthesia, our learning becomes active in the sense that you discover and work with content that you determine to be necessary to solve the problem.

Problem based learning will provide you with opportunities to

- **examine and try out what you know**
- **discover what you need to learn**
- **develop your people skills for achieving higher performance in teams**
- **improve your communications skills**
- **state and defend positions with evidence and sound argument**
- **become more flexible in processing information and meeting obligations**
- **practice skills that you will need after your education**

Case 1-Preoperative Evaluation

A 45-year-old man is undergoing a preoperative evaluation for a laparoscopic cholecystectomy due to acute cholecystitis. He has a history of rheumatoid arthritis for 10 years. After the evaluation, the anesthesiologist determines that the patient is ASA status 3.

- **What are THE GOALS OF PREOPERATIVE ASSESSMENT?**
- **What does ASA status 3 mean?**
- **What is the focus of the anesthesia evaluation of the arthritis, cardiac patients and chronic obstructive lung disease patients?**
- **What is the NPO Status required preoperative?**
- **What is Preoperative Medications you can use ?**

Case 2-Unexplained Apnea under Anesthesia

A 15-year-old boy underwent elective right knee arthroscopy and debridement under general anesthesia with a laryngeal mask airway (LMA and spontaneous breathing). He was otherwise healthy with no allergies to medications. After uneventful induction of anesthesia, the surgeons requested antibiotic prophylaxis with cefazolin 1 gram, which the anesthesiology team administered. Just before the surgical incision was made, 50 mcg of Fentanyl was administered. About 2 minutes later, spontaneous respirations slowed, and the patient became apneic. The surgeon and anesthesiologist assumed the patient's apnea was due to opiate sensitivity and assisted ventilation by hand for 30 minutes. However, despite a rise in the end-tidal CO₂ to 70mm Hg, spontaneous respirations did not return. The anesthesia team examined the drawer and found vials of cefazolin and vecuronium (a long-acting paralytic agent) in adjacent medication slots. The vials were of the same size and shape.

- Discuss etiologies of Apnea during anesthesia .
- Discuss receiving unplanned drug due to a syringe or an ampoule swap.
- Discuss treatment of medication-induced respiratory depression varies by cause.
- Discuss in the case of persistent peripheral muscle blockade, typically due to residual muscle relaxants, the use of peripheral nerve stimulator, reversal with neostigmine is initiated.
- Discuss wrong medication administration in the operating room is due to failure to label syringes and interventions to prevent medical and blood transfusion errors.

Case 3- Postoperative Hypotension

66-year-old mother of two young children, attended as an inpatient for an elective vaginal hysterectomy and repair of prolapsed under spinal anesthesia . She had no relevant past history and her preoperative assessment was unremarkable. During surgery, blood loss was greater than usual at 800 ml but no other problems were noted. In the recovery room she was well but noted to be pale and agitated, complaining of abdominal pain. An hour later as she had become unwell, pale and hypotensive with a borderline tachycardia (BP 90/60 mm Hg, pulse 122 bpm)

- **Discuss differential diagnoses such as loss of blood at the operation site , anaphylaxis and myocardial depression.**
- **Discuss clinical indicators of hypovolemia, monitoring and assessment.**
- **Discuss Managements of postoperative hypotension**
- **Discuss when to give blood and how much blood to be given .**

Case 4-Difficult airway

A 35-year-old woman presents for laparoscopic lysis of adhesions. Her first laparotomy occurred 10 years prior to this admission. At that time, the process of tracheal intubation consumed 1 hour. She awakened with a very sore throat, but does not know the details of the intubation.

The old records are unavailable.

- **What are the predictors of difficult mask ventilation?**
- **Discuss the risk factors for difficult intubation.?**
- **How is the anticipated difficult intubation approached?**
- **Describe the management options for a patient who, after induction of anesthesia, unexpectedly cannot be intubated with a Macintosh blade. This patient has a good mask airway.**
- **Following induction of anesthesia, ventilation by facemask and intubation are impossible. What maneuvers may help?**
- **How is successful tracheal intubation verified?**
- **Following a difficult intubation, how is postoperative extubation managed?**

Case 5- Hypoxia after anesthesia

A 37 years of age male who arrives in the PACU following surgical removal of his gallbladder. Surgical intervention utilizing the laparoscopic approach is successful. Patient history obtained during the preoperative phase of care showed that he was a 2 pack/day smoker and he denies taking any prescribed medications with no other medical problems. He reports that his pain is 6 on a 10-point scale. He states that he has pain in his shoulder and pressure in his abdomen. Morphine (5 mg) is ordered for the pain, and 4 mg is administered IV. At 1 hour after admission, the patient's oxygen saturations were 89% to 90%, his respiratory rate is 16 breaths per minute, and he is more difficult to arouse.

- Discuss hypoxia and possible causes after anesthesia
- Was this patient hypoxemic?
- Discuss hemoglobin oxygen dissociation curve
- Discuss clinical assessments and management of postoperative hypoxia
- Discuss effect of smoking on respiratory system
- Does the patient's history of smoking may be the cause of the respiratory insufficiency?

Case 6-Local Anesthetic Infiltration

A 25-year-old, 75-kg man presents for open appendectomy. The surgery is performed under general anesthesia, without complications. After the specimen is removed, the attending surgeon leaves the operating room to dictate the operative report, leaving the intern and medical student to close the skin. Upon leaving, the surgeon asks them to “inject some local anesthetic into the wounds.” The intern turns to you and asks

which local anesthetic you suggest and how much to inject.

- What are the benefits of local anesthetic infiltration?
- What attributes are you looking for in a local anesthetic in this case?
- Which agent would you choose and what is the maximum dose?
- What are the complications might be expected from overdose?

Case 7-Muscle Relaxants (Neuromuscular Junction Blockers)

A 47-year-old patient is undergoing the clipping of an intracranial aneurysm of the anterior communicating artery under general anesthesia. The surgery is being performed under a microscope, so even the smallest movement by the patient could have devastating consequences.

- **How can the patient be protected and the surgery allowed to proceed?**
- **What are the Clinical Pharmacology of the Neuromuscular Blockers?**
- **Maintenance of Blockade: How Much is Enough?**
- **Reversal of the Neuromuscular Blockade and Emergence**

Case 8-APPROACH TO Patient Monitoring

The surgeons have requested a brief general anesthetic for change of dressing to an open infected wound. They suggest that the procedure can be performed in the patient's bed on the hospital floor.

- **Does this patient need special monitoring for this procedure?**
- **What this patient's monitoring must adhere to the standards for basic monitoring published by the American Society of Anesthesiologists.?**
 - 1. Oxygenation**
 - 2. Ventilation**
 - 3. Circulation**
 - 4. Temperature**
 - 5. Urine Output**
 - 6. Invasive Monitoring**
 - 7. Monitoring of Neurological Function**
 - 8. Monitoring of Neuromuscular Function**

Case 9- Fluid Replacement Therapy

A 54-year-old man is undergoing a laparotomy and colon resection for carcinoma. The anesthesiologist is attempting to calculate the fluid replacement.

- What are the components that must be considered when calculating
- the volume of fluid that should be replaced?
- What are the SIGNS OF PREOPERATIVE HYPOVOLEMIA?
- How to calculate the fluid replacement in the intraoperative period all of which take into consideration the preoperative fluid deficits, intraoperative blood loss, and urine output.?
- Which of Fluids: Crystalloid vs Colloids , you can use and when to use ?

Case 10-Anesthesia for healthy patient

A 52-year-old man has had progressive knee pain with swelling, His orthopedic surgeon has tentatively diagnosed a torn meniscus, and recommended an arthroscopy as an outpatient. The patient has had no major illnesses other than the typical childhood diseases. He has had no previous operations or anesthetics, nor a family history of problems with anesthesia. He has no allergies to medications, does not smoke, and consumes alcohol occasionally at social events. His laboratory results and physical examination by an internist were all normal. He has had nothing to eat or drink since he went to bed last night. On examination, the patient weighs 75 Kg and is 182 Cm, in tall. His neck appears to be flexible and mobile. He opens his mouth without difficulty, and with his head extended and tongue protruding, his uvula is completely visible.

- How are a patient's general medical condition, and his risk for difficult airway management classified?
- In which stage of anesthesia is the patient most vulnerable, and why?
- Which components of a pre-anesthetic evaluation are often not included in a patient's typical history and physical examination?

Case 11- Rapid Sequence Induction (RSI):

A 27-year-old woman presents to the emergency department complaining of abdominal pain, nausea, and vomiting. Her pain began in the peri-umbilical region and has now migrated toward the right lower quadrant of the abdomen. A surgery consult is obtained, and based on her history, physical, and findings suggestive of acute appendicitis seen on abdominal CT scan, she is scheduled for emergency appendectomy. The patient is otherwise healthy and takes no regular medications. Her surgical history includes a tonsillectomy at age 10, and a dilatation and curettage (D&C) at age 25. She has not had problems with previous anesthetics.

- **What would you include in your preoperative evaluation of this patient?**
- **What medications will you use for induction and maintenance of anesthesia?**
- **How will you manage postoperative pain in this patient?**
- **What considerations are warranted in this healthy, young woman scheduled for an emergency surgical procedure if she have full stomach,”?**