

Pharmacology of Anesthesia

Dr. Mansoor Aqil
Professor Anesthesiology
KING SAUD UNIVERSITY, RIYADH

Lecture Objectives..

Students at the end of the lecture will be able to:

1. Understand pharmacokinetics and pharmacodynamics of general anaesthetic agents: intravenous agents, inhalation agents, Opioids, neuromuscular blocking agents and reversal agents as well as local anaesthetic agents.
2. Learn about the main uses, advantages and disadvantages of these agents.
3. How to deal with adverse reactions diagnosis and management of Malignant hyperthermia and Succinylcholine apnea.

Anesthetic Agents

Intravenous Anesthetics:

Barbiturates, Propofol, Etomidate, Ketamine.

Opioids.

Inhalational Anesthetics:

- Sevoflurane, Isoflurane, Desflurane, Halothane and Nitrous Oxide.

Neuromuscular blocking drugs.

Adjunct to General Anesthesia: Benzodiazepines,
Dexmedetomidine

Local Anesthetics: Lidocaine, Bupivacaine, Ropivacaine.

Intravenous Anesthetics



Barbiturates

Thiopental (thiopentone sodium) is a thiobarbiturate.

Mechanism of action

- Facilitate inhibitory neurotransmission by enhancing GABAA receptor function.
- Inhibit excitatory neurotransmission via glutamate and nicotinic acetylcholine receptors.

Pharmacokinetics

Metabolism and elimination is hepatic.

Multiple doses or prolonged infusions may produce prolonged sedation or unconsciousness

Pharmacodynamics

CNS

Dose-dependent CNS depression. ↓ in (CMRO₂), cause ↓ in ICP and (CBF).

Cardiovascular system

- Depress myocardial contractility, leading to dose-dependent ↓ in BP and cardiac output,
- Baroreceptor reflexes remain largely intact.

Respiratory system

- Dose-dependent decrease in RR and TV.
- Apnea may last for 30 to 90 seconds after induction dose.
- Laryngeal reflexes remain more intact compared to propofol so higher incidence of cough and laryngospasm during LMA insertion.

Primary Use:

Induction of anesthesia.

Advantages:

- Rapid onset (30 - 45 sec), short duration (5 – 8 min) initial dose; redistributed from brain to muscle resulting in return of consciousness.
- It has potent anticonvulsant properties.

Adverse effects:

Dose dependent histamine release.

- Myoclonus and hiccups .
- Absolutely contraindicated in Porphyria
- Venous irritation and tissue damage

- Thiopental can cause severe pain and tissue necrosis if injected subcutaneously or intra-arterially.
- If intra-arterial administration occurs, heparin, vasodilators, and regional sympathetic blockade may be helpful in treatment.

Dosage and administration

Induction: IV 3-6 mg/kg

Sedation IV 0.5-1.5 mg/kg

N.B. Reduce doses in hypovolemic, elderly, or hemodynamically compromised patients.

PROPOFOL (2, 6- diisopropylphenol)

It is the most widely used induction agent.
1% isotonic oil-in-water emulsion, which contains egg lecithin, glycerol, and soybean oil.



Mechanism of action

Facilitates inhibitory neurotransmission by enhancing the function (GABAA) receptors in CNS.

Pharmacokinetics

Hepatic and extrahepatic metabolism leads to inactive metabolites which are excreted by renal route.

Pharmacodynamics

CNS

- Induction : rapid onset of unconsciousness (30 to 45 seconds), followed by a rapid termination of effect by redistribution, so emergence is rapid.
- Weak analgesic effects.
- ↓ (ICP) and ↓ (CPP) due to markedly ↓ (MAP).
Anticonvulsant.
- Less (PONV) occurs.

Cardiovascular System

Dose-dependent ↓ in preload, afterload, and contractility lead to ↓ in (BP) and COP.



- Hypotension may be marked in hypovolemic, elderly or hemodynamically compromised patients.
- Heart rate (HR) is minimally affected, and baroreceptor reflex is blunted.



Respiratory system

- Dose-dependent decrease in (RR) and (TV).
- ↓Ventilatory response to hypoxia and hypercarbia.

Primary Uses

- A sedative/hypnotic in OR & ICU.
- Induction of anesthesia.
- Maintenance of anesthesia (TIVA).

Advantages



- Produces Laryngeal & pharyngeal muscle relaxation, allowing LMA insertion.
- Safe in Malignant hyperthermia (MH) & Porphyrria patients.
- Antiemetic properties.
- Suitable for day case surgery to avoid prolong postoperative hangover (drowsiness, ataxia).
- Situations where volatile anesthetics cannot be used (MH, transfer of sedated patients, airway surgery).

Adverse effects



- Venous irritation.
- Bacterial growth
- Lipid disorders. used cautiously in disorders of lipid metabolism (e.g., hyperlipidemia and pancreatitis).
- Myoclonus and hiccups
- Propofol infusion syndrome:
A rare fatal disorder that occurs in critically ill patients (usually children) subjected to prolonged, high-dose propofol infusions. (Rhabdomyolysis, metabolic acidosis, cardiac failure, and renal failure).

Dosage and administration

Induction: IV 1-2.5mg/kg

Sedation : IV 25-100 μ /kg/min



Titrate with incremental doses in hypovolemic, elderly, or hemodynamically compromised patients or if administered with other anesthetics.

Etomidate

It is a carboxylated imidazole.

Mechanism of action

Facilitates inhibitory neurotransmission by enhancing the function (GABAA) receptors.

Pharmacokinetics

Effects of a single bolus dose are terminated by redistribution.

Very high clearance in the liver and by circulating esterases to inactive metabolites.



Pharmacodynamics

CNS

No analgesic properties.

↓ (CBF), cerebral metabolic rate (CMR), and (ICP).

Cardiovascular System

Minimal changes in HR, BP, and COP.

Respiratory system

Dose-dependent ↓ in (RR) & (TV).

Transient apnea may occur.



Primary Uses

Induction of anesthesia in patients with cardiovascular problems.

Advantages

Short acting and potent, with CVS and RS stability, suitable for elderly and shocked patients.



Adverse effects

1. Excitatory phenomena (Involuntary limb twitches), myoclonus
2. Nausea and vomiting.
3. Venous irritation and superficial thrombophlebitis
4. Adrenal suppression, (Inhibits 11β & 17α hydroxylase).
5. A single dose suppresses adrenal steroid synthesis for up to 24 hours. Repeated doses /infusion is associated with increased mortality in ICU patients.

Dosage and administration

Induction: IV 0.2-0.5 mg/kg

Ketamine

It is phencyclidine derivative causing
'dissociative anesthesia'



Mechanism of action

Mainly attributed to noncompetitive antagonism of NMDA receptors in the CNS

Pharmacokinetics

- Terminated by redistribution in 15 to 20 minutes.
- Metabolized rapidly in the liver to multiple metabolites, some of which have modest activity (e.g., norketamine).
- Elimination half-life is 2 to 3 hours.

Pharmacodynamics

CNS

Unconsciousness in 30 to 60 s after an IV.

Amnesia and profound analgesia.

↑ (CBF), ↑ (CMR), and ↑(ICP) pressure.

Cardiovascular System

↑ HR, COP, and BP.

Used in hemodynamically compromised patients.

Respiratory system

Mild depression of (RR) and (TV).

Potent bronchodilator.

Laryngeal protective reflexes are maintained.



Primary Uses

Induction of general anesthesia.

Sedation and analgesia.

Advantages

CVS stability makes it suitable for shocked patients.

Preservation of airway reflexes & less respiratory depression makes it suitable for procedures – radiological interventions, radiotherapy, burns & dressing changes.

Adverse effects

↑ salivation, PONV.

Emotional disturbance, agitation & hallucinations.

Contraindicated in patients with head trauma

Dosage and administration

Induction: IV 1-2mg/kg , IM 3-5mg/kg

N.B. Useful for IM induction in patients with no IV access (e.g., children).



Opioids



Opioids



Opioids produce moderate sedation and profound analgesia. Fentanyl, Sufentanil, Alfentanil, Remifentanil, Meperidine, Morphine.

Mechanism of action

They exert their effects by binding with opioid receptors in CNS 3 major opioid receptors μ (mu), κ (kappa), and δ (delta).

Primary Uses



1. They mimic endogenous compounds: Endorphins, enkephalins & dynorphins.
2. Principally provides analgesia and some degree of sedation.
3. Large doses can produce general anesthesia.

Advantages

Minimal cardiac effects (No myocardial depression).

Adverse effects

- Miosis
- Nausea & vomiting, slow gastric emptying, constipation
- Drowsiness or sedation
- Chest wall rigidity & respiratory depression
- Bradycardia in large doses
- Some peripheral vasodilation and histamine release – hypotension
- Itching
- Urinary retention & biliary colic,



Fentanyl

- A potent synthetic opioid agonist with 100 times, the analgesic potency of morphine.
- Used for induction and maintenance of G.A and to supplement regional and spinal anesthesia.
- Ability to maintain cardiac stability.



Sufentanil citrate (Sufenta)

- 10 times as potent as fentanyl
- Rapid elimination
- Relatively more rapid recovery as compared with fentanyl.



Alfentanil

Shorter duration of action compared to fentanyl and sufentanil,

Remifentanil (Ultiva)

- Ultra short acting and rapidly cleared
- Widespread extrahepatic metabolism by blood and tissue nonspecific esterases



Morphine

- May produce hypotension and bronchoconstriction as a consequence of its histamine-releasing action.
- Morphine may be a poor choice for a patient with renal failure.



Naloxone



A specific opiate receptor antagonist, binding the receptor.

The effective dose is 1 to 4 $\mu\text{g}/\text{kg}$ IV, and the duration of action is 30 to 45 min.

Dose may need to be repeated or as an infusion

Adverse effects

- Reversal of analgesia, nausea, vomiting,
- Increased sympathetic nervous system activity (tachycardia, hypertension, pulmonary edema, and cardiac dysrhythmias).

Benzodiazepines



Benzodiazepines

Midazolam, lorazepam, and diazepam.

Mechanism of action

Enhance inhibitory neurotransmission by increasing the affinity of GABAA receptors for GABA.

Pharmacokinetics

- Effects are terminated by redistribution.
- All are metabolized in the liver.
- Hydroxymidazolam cause sedation in Pt with renal failure.
- Diazepam clearance is reduced in the elderly.

Pharmacodynamics

CNS

- Amnesic, anticonvulsant, anxiolytic, and sedative-hypnotic (dose-dependent manner).
- No analgesia.

Cardiovascular System

Mild systemic vasodilation and ↓ in cardiac output. HR is usually unchanged.

Respiratory system

- Mild dose-dependent ↓ in RR and TV.
- Respiratory depression may be more if administered with an opioid

Primary Uses

Sedation, amnesia, anxiolytic use
as premedication or as adjunct to GA

Adverse effects

- Drug interactions with anticonvulsant (valproate)
- Pregnancy and labor :
 - Risk of cleft lip and palate in the first trimester.
 - CNS depression in the neonate.
- Superficial thrombophlebitis and injection pain by diazepam and lorazepam.
- They cause mild respiratory depression but can be marked in elderly leading to apnea.



Midazolam (Dormicum)



- Water soluble, so drug of choice for IV administration
- More rapid onset and more rapid elimination
- The most potent amnestic

Diazepam (Valium)

Water-insoluble, so IV use can cause local irritation/pain

Lorazepam (Ativan)

Water-insoluble.

Flumazenil

- **A competitive antagonist at the benzodiazepine binding site of GABAA receptors in the CNS.**
- Reversal of sedative effects occurs within 2 min; peak effects at 10 min.
- **Half-life is shorter** than the benzodiazepine
- Metabolized to inactive metabolites in the liver.
- **Dose.** 0.3 mg IV every 30 to 60 seconds (to a maximum dose of 5 mg).
- Initial dose in pediatric: 0.01 mg/kg IV over 15 seconds
- **Contraindicated** in patients receiving benzodiazepines for the control of seizures or elevated ICP.



DEXMEDETOMIDINE

- Dexmedetomidine is a new generation highly selective α_2 -adrenergic receptor (α_2 -AR) agonist that is associated with sedative and analgesic sparing effects, reduced delirium and agitation, perioperative sympatholysis, cardiovascular stabilizing effects, and preservation of respiratory function.

Inhalational Anesthetics



Characteristics of the ideal inhaled anesthetic agent:

- Non - toxic, non-.allergenic, non - irritant.
- Stable in storage, non – flammable
- No extra specialist equipment required.
- Low solubility in blood and tissues.
- Resistance to physical and metabolic degradation.
- Analgesic.
- CVS- no effect.
- No respiratory depression.
- Environmentally inert.
- No reaction to soda lime/ breathing circuit.
- Not a malignant hyperthermia (MH) trigger.

Volatile anesthetics

Present as liquids at room temperature and pressure.

Vaporized into gases for administration

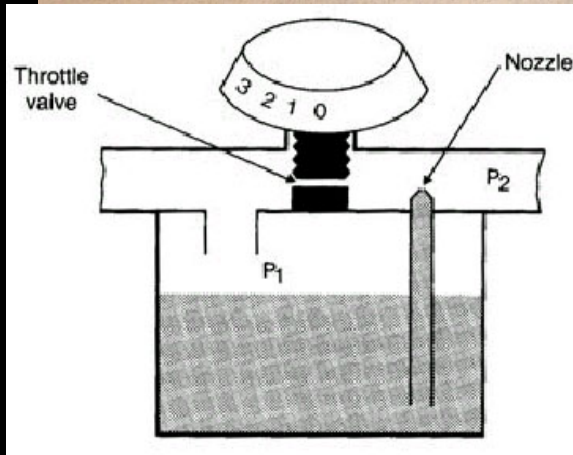

The minimum alveolar concentration (MAC)

‘The amount of vapor (%) needed to render 50% of spontaneously breathing patients unresponsive to a standard painful surgical stimulus.’

- Halothane 0.75%
- Isoflurane, 1.15%
- Sevoflurane, 1.85%
- Desflurane 6.0% at one atmosphere.

Mechanism of action

Various ion channels in the CNS involved in synaptic transmission (including GABA_A, glycine, and glutamate receptors) may play a role.

Pharmacokinetics

The higher the vapor pressure, the more volatile the anesthetic.

Blood solubility determines the speed of build-up / elimination from blood / brain

Lower blood solubility means (faster induction/recovery)

Inspired air → Alveolar air → Blood → Brain

Metabolism: hepatic.

Exhalation: This is the predominant route of elimination:

Pharmacodynamics

CNS

- Unconsciousness and amnesia . ↑ cerebral blood flow (CBF).

Respiratory System

- Dose-dependent respiratory depression
- Airway irritation and, during light levels of anesthesia, may precipitate coughing, laryngospasm, or bronchospasm (sevoflurane makes it more suitable)
- Bronchodilator (with the exception of desflurane).
- Inhibit hypoxic pulmonary vasoconstriction.

Renal system.

- ↓ renal blood flow.

Cardiovascular System

- Myocardial depression & systemic vasodilation.
- HR tends to be unchanged, except desflurane
- Sensitize the myocardium to the arrhythmogenic effects of catecholamines.

Neuromuscular system

- Dose-dependent ↓ in skeletal muscle tone.
- May precipitate malignant hyperthermia ... A dramatic increase in body temperature, acidosis, electrolyte imbalance and shock.
- Management is removal of triggering agent, 100% Oxygen, active cooling measures & Dantrolene (1 to 10 mg/kg)

Hepatic System

↓ hepatic perfusion.

Desflurane

Advantages

Rapid onset and recovery of anesthesia
(outpatient procedures)

One of least metabolized to toxic byproducts

Disadvantages

Requires a special vaporizer

Pungent and irritating to the airway (leading to more coughing, laryngospasm)

High inspired gas concentrations lead to a significant \uparrow in the patient's BP & HR.



Sevoflurane



Advantages

- Low solubility in blood-- produces rapid induction and emergence
- Pleasant smelling (suitable for children)
- Has good bronchodilating properties
- Agent of choice in asthma, bronchitis, and COPD.
- It has little effect on the heart rate.
- Mild respiratory and cardiac suppression

Disadvantages

- Carbon dioxide absorbents in anesthesia machines degrade sevoflurane to Compound A

Isoflurane:



Advantages:

It causes peripheral vasodilation and increased coronary blood flow.

Disadvantages:

- Moderate solubility, so recovery from anesthesia may be delayed
- Isoflurane can make the heart “more sensitive” to circulating catecholamines (like epinephrine).

Halothane

- Used for induction in children (sweet pleasant odor);
- Sensitize the myocardium to the arrhythmogenic effects of catecholamines.
- Blood pressure usually falls.
- Very soluble in blood and adipose tissue
- Prolonged emergence
- “Halothane hepatitis” (rare).



Nitrous Oxide

MAC is 104% at one atmosphere

CNS

- Antagonism of NMDA receptors in CNS. Weak anesthetic, produce analgesia.
- Usually combined with other anesthetics.
- Used alone e.g. dental procedures.

Cardiovascular system

Mild myocardial depressant & a mild sympathetic stimulant.

HR and BP are usually unchanged.

↑ pulmonary vascular resistance.

Respiratory system

Little effect on respiration



Disadvantages

- Nausea/vomiting.
- Risk of bone marrow depression
- Inhibits vitamin B-12 metabolism
- Expansion of closed gas spaces. Nitrous oxide is 35 times more soluble in blood than nitrogen. Contraindicated in (e.g. air embolus, pneumothorax, Middle Ear Surgery etc)
- Diffuse into the cuff of ETT.
- Diffusion hypoxia. After discontinuation, its rapid elimination from the blood into the lung may lead to a low partial pressure of oxygen in the alveoli.



Neuromuscular blocking drugs

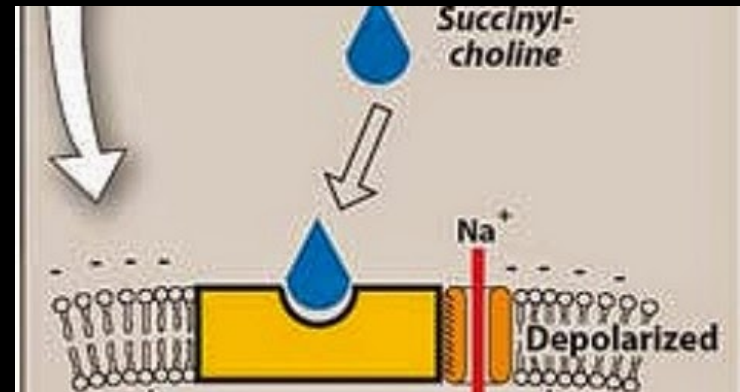
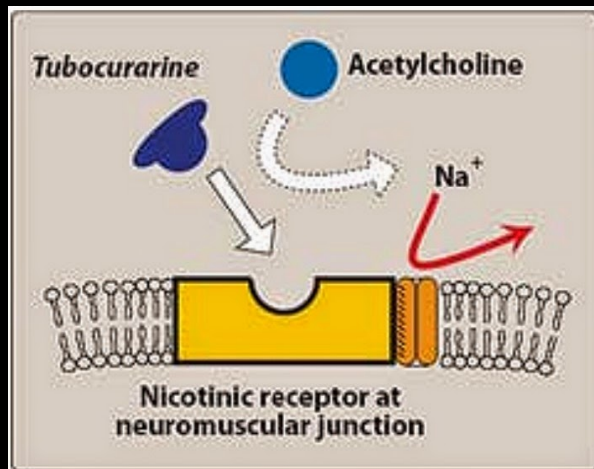

Neuromuscular blocking drugs

Primary Uses

- Perform tracheal intubation.
- Facilitate ventilation.
- Provides optimal surgical operating conditions.

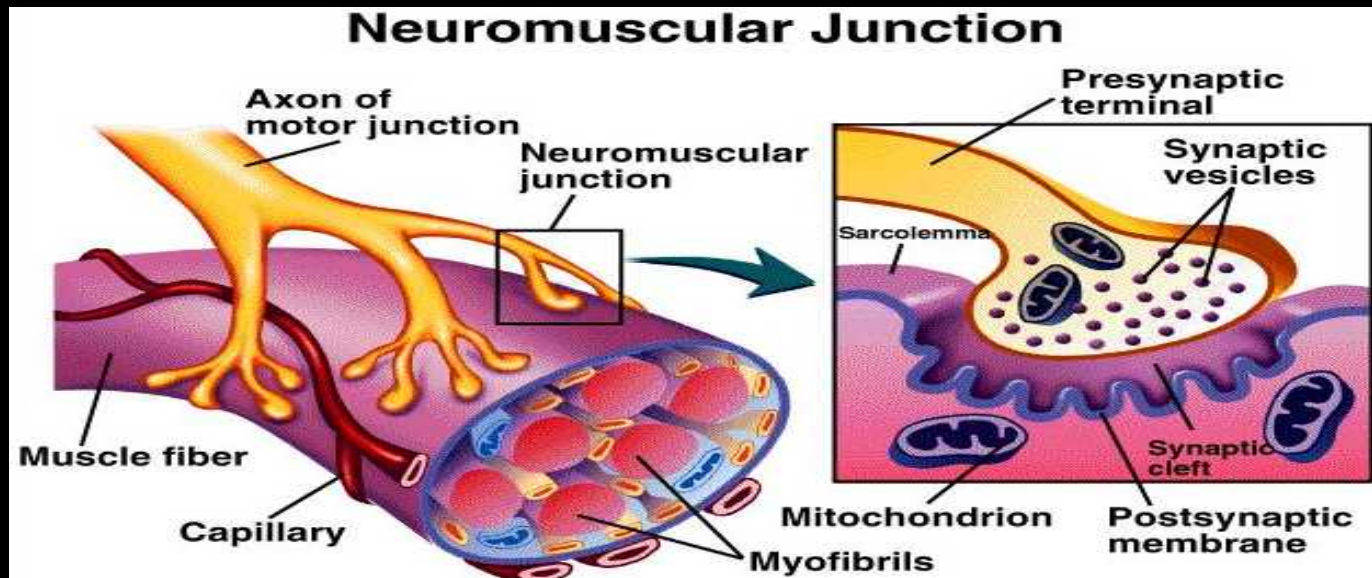

Neuromuscular blockers

Table 9-1. Depolarizing and nondepolarizing muscle relaxants.

Depolarizing

Short-acting
Succinylcholine

Nondepolarizing

Short-acting
Mivacurium
Intermediate-acting
Atracurium
Cisatracurium
Vecuronium
Rocuronium
Long-acting
Doxacurium
Pancuronium
Pipecuronium

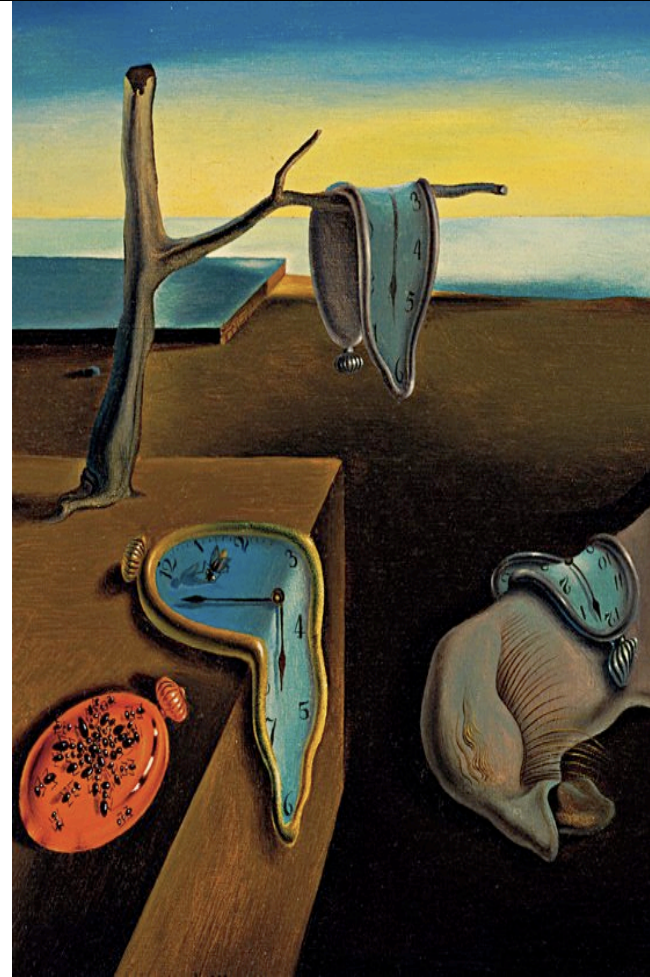

Depolarizing (Succinylcholine)



Structurally similar to acetylcholine ... activate the acetylcholine receptors (ACh) ... depolarization of post junctional membrane.

Very short duration of action (onset 60 seconds/ duration 10 minutes)

For Rapid sequence induction and intubation

Metabolized very quickly by plasma cholinesterase.

Characterized by transient muscle fasciculations followed by relaxation.

Acetylcholine esterase (AChE) inhibitors **potentiate** rather than reverse the block.

Adverse Effects

- Cardiac dysrhythmias: sinus bradycardia, junctional rhythm, and even asystole after the first dose in children and following repeated dose within a short time interval in adults.
- Hyperkalemia.(burns, RF, muscular dystrophies & paraplegia)
- A transient increase in intraocular pressure (IOP)
- Increase in intracranial & intragastric pressure.
- Myalgia : abdomen, back, and neck.
- Histamine release.
- Dual block.



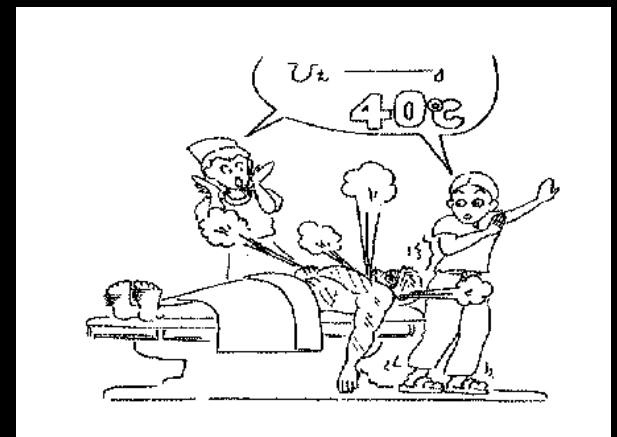

Succinylcholine apnea

- Low levels of plasma cholinesterase (severe liver or kidney disease)
- A drug-induced inhibition of its activity or genetically atypical enzyme.
- Management is supportive, especially to avoid awareness.
- Anaphylaxis. over 50% of anaphylactic reactions to NMBDs.
- **Malignant hyperthermia (MH).**

Non-depolarizing blockers

They act by competitively blocking the binding of ACh to its receptors and inhibit muscular contraction.

It is characterized by :

- Absence of fasciculation.
- Potentiation by other nondepolarizing NMBDs and volatile anesthetic agents.
- Reversal by AChE inhibitors.

MIVACURIUM:

Short-acting,

rapidly hydrolyzed by plasma cholinesterase.



Histamine release causing a transient hypotension and tachycardia.

ATRACURIUM:

Widely used and have an intermediate onset and duration of action.

- Histamine release.
- No direct cardiovascular effects.
- Metabolism is by Hofmann degradation and ester hydrolysis in the plasma.
- Its duration of action is independent of renal and hepatic function.
- A breakdown product of atracurium, (laudanosine) may accumulate and cause seizures

CISATRACURIUM: Isomer of atracurium

- Hofmann degradation and does not accumulate in renal failure.
- Relatively slow onset of action.
- Does not release histamine.
- Less laudanosine.



ROCURONIUM: The most rapid onset of the clinically available non-depolarizing NMBDs.

- Intubating conditions can be achieved in 60-90 seconds after an induction dose of 0.6 mg/Kg.
- Increasing the dose to 1.2 mg/kg shortens the time can be used for rapid sequence induction when Suxamethonium is contraindicated.
- An intermediate duration of action. Histamine is not released.
- Higher incidence of anaphylactic reaction.

CHOICE OF NMBD

- Urgency for tracheal intubation.
- Duration of the procedure,
- Coexisting medical conditions that may affect the NMJ.
- Side effects & metabolism
- Cost-effectiveness
- Suxamethonium makes it a good choice for rapid intubation.
- Rocuronium will decrease the risk of hyperkalemia in patients with burns.
- Pancuronium can produce a tachycardia that is undesirable in patients with severe IHD, but its vagolytic effects may be appropriate in pediatrics.

Peripheral nerve stimulator

- Check the depth of neuromuscular blockade
- Determine that neuromuscular blockade is reversed
- At least **3 twitches** on a train of four should be detected before attempting reversal.



Anticholinesterases (Neostigmine)



- They inhibit the action of the acetylcholinesterase enzyme at the NMJ resulting in increase in the concentration of Ach at NMJ.
- Clinical tests of adequate resolution of neuromuscular block include the ability to lift the head from the bed for 5 seconds.
- Intravenous injection at a dose of 0.05 mg/kg (maximum 5mg).
- To minimize adverse effects such as bradycardia, miosis, GI upset, nausea, bronchospasm, increased sweating, salivation & bronchial secretions, an antimuscarinic such as **glycopyrronium** 0.01 mg/kg or **atropine** 0.02 mg/kg must be administered along with the anticholinesterase.

SUGAMADEX

- Selective relaxant binding agent for reversal of neuromuscular blockade (NMB) induced by rocuronium or vecuronium in adults.
- Sugammadex is not effective in reversing nondepolarizing neuromuscular blockade secondary to benzylisoquinoline relaxants. Dose is 2, 4 and 16mg/kg.
- Sugammadex is essentially eliminated unchanged via the kidneys.

Local anesthetics (LAs)

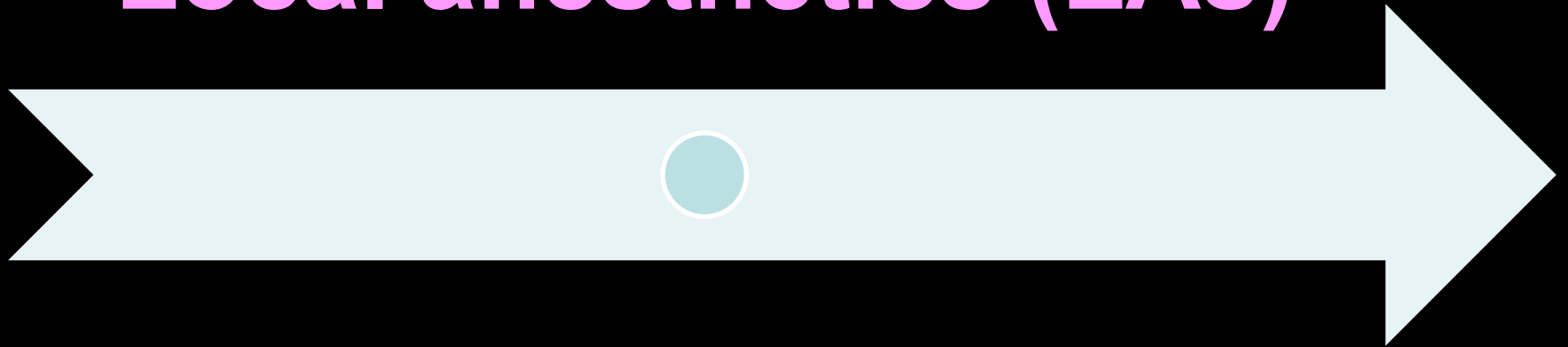

Local anesthetics

LAs are drugs which reversibly prevent the transmission of pain stimuli locally at their site of administration.

Mechanism of action

Reversibly blocking sodium channels to prevent depolarization

Lipid solubility is related to potency and plasma protein binding determines duration of action of LA.

Addition of vasoconstrictor:

Prolongation of anesthetic action, decreased risk of toxicity and decrease in bleeding from surgical manipulation

1. Esters (metabolized by plasma cholinesterase)

- Cocaine (out of date)
- Benzocaine
- Procaine
- Tetracaine

2. Amides (metabolized by cytochrome p-450)

- Lidocaine
- Bupivacaine
- Mepivacaine
- Prilocaine
- Ropivacaine

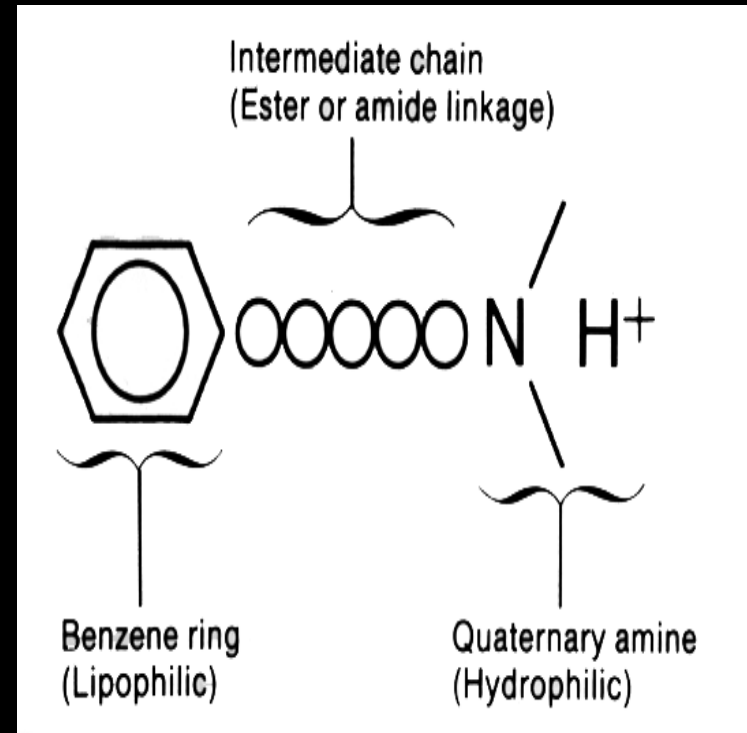

Applications of local anesthesia

- Topical application: To skin for analgesia (e.g., benzocaine) or mucous membranes (for diagnostic procedures)
- Nerve block: (e.g., dental and other minor surgical procedures)
- Plexus block
- Spinal & epidural anesthesia:
- Local infiltration: At end of surgery to produce long-lasting post-surgical analgesia (reduces need for narcotics)
- I/V infusion: For control of cardiac arrhythmias (e.g., lidocaine for ventricular arrhythmias)

Choice of local anesthetics

- Onset
- Duration
- Sensory vs. motor block
- Potential for toxicity

LIDOCAINE: The most commonly used amide type local anesthetic.

- Rapid onset and a duration of 60-75 minutes, extended with epinephrine for up to 2 hours.
- Metabolized in the liver and excreted by the kidneys.
- Contraindicated in patients with a known sensitivity.
- Has also antiarrhythmic action.

BUPIVACAINE:

- Onset of action is slower than lidocaine and anesthesia is long acting - 2-4 hours, extended with epinephrine for up to 7 hours.
- More cardio-toxic than lidocaine and ropivacaine and difficult to treat.
- Metabolized in the liver and excreted by the kidneys
- Contraindication: known hypersensitivity

ROPIVACAINE:

- Less toxic, long-lasting LA.
- Undergoes extensive hepatic metabolism, with only 1% of the drug eliminated unchanged in the urine.
- Ropivacaine is slightly less potent than bupivacaine.

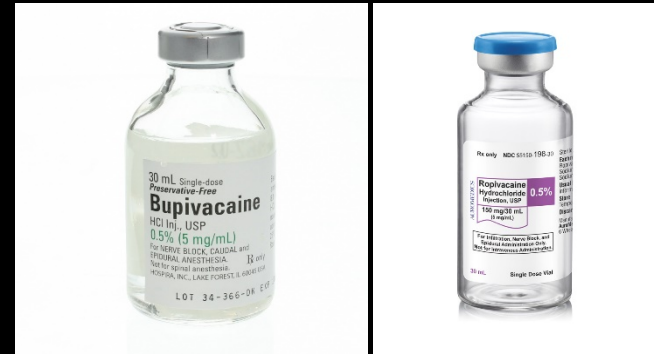

Local Anesthetic Toxicity

CNS:

- Initially circumoral numbness, dizziness, tinnitus, visual change. Later drowsiness, disorientation, slurred speech, loss of consciousness, convulsions & finally respiratory depression

Cardiovascular System:

- Myocardial depression and vasodilation--hypotension and circulatory collapse

Allergic reactions:

- Rare (less than 1%) rash, bronchospasm

Prevention and Treatment of Toxicity

All Cases: Assure adequate ventilation & administer supplemental Oxygen.

- Seizures: Midazolam
- Hypotension: Trendelenburg position
(head down , legs up),
- IV fluid bolus (Isotonic Saline or LR),
- Vasopressor (Dopamine if refractory to above).
- Intralipid 20%
- Dysrhythmias: As per ACLS protocol (but do not administer further Lidocaine)

Thank You

CASE DISCUSSION

A 4 years old male patient booked for Rt. eye squint surgery.

- How you will assess this patient preoperatively?
- Discuss fasting time & premedication?

The patient seen in preoperative anesthesia clinic & cleared

- What are the physiological difference b/w adult & pediatric patient?
- Discuss anesthesia consideration & special concern for such surgery?
- Discuss anesthesia plan?

During surgery the patient developed severe bradycardia

- Discuss the cause and treatment?

Surgery lasted for 2 hours, extubated & shifted to recovery

- What is your post-operative treatment plan?